



CJ6101 Series Low-dropout Regulator

1 Introduction

The CJ6101 series is a group of low dropout positive voltage regulators with ultra-low quiescent power consumption manufactured by CMOS technology. It can provide 300mA output current, and can provide large output current even when the input and output voltage difference is very small. Because of their ultra-low quiescent current, the CJ6101 series are very suitable for battery powered equipment, such as RF applications and other systems requiring quiet voltage sources, to improve the efficiency of these systems and prolong the battery life of the device.

2 Naming Scheme

Part Number: CJ6101①②③④		
DESIGNATOR	SYMBOL	DESCRIPTION
①	A	Standard
	B	With enable function
②③	Integer	Output Voltage, e.g. 2.8V = ②:2, ③:8
④	M / MC / MY	Package: SOT-23-3L
	M / MF / MR	Package: SOT-23-5L
	P / PT / PL	Package: SOT-89-3L
	F	Package: DFNWB1×1-4L

Note: For more detailed packaging information, see the part *Pin Configuration* and the part *Mechanical Information*.

3 Features

- Input Voltage Range: 1.8V ~ 6.0V
- Fixed Output Voltage:
Designed for 1.0V to 5.0V Output
- Output Voltage Tolerance:
±2% for Conventional Device
±1% can be Customized
- Output Current: 300mA
- Quiescent Current: 0.8µA (Typ.)
- Dropout Voltage:
110mV@100mA ($V_{OUT} = 3.3V$)
- Power Supply Rejection Ratio:
50dB@1kHz
- Low Output Noise:
 $27 \times V_{OUT} \mu V_{RMS}$ (10Hz ~ 100kHz)
- Good Transient Response
- Integrated Fault Protection:
 - Fold-back Current Limit
 - Thermal Shutdown
 - Short-Circuit Protection

4 Applications

- Portable Consumer Equipments
- Radio Control Systems
- Laptop, Palmtops and PDAs
- Wireless Communication Equipments
- Portable Audio Video Equipments
- Ultra Low Power Micro-controller

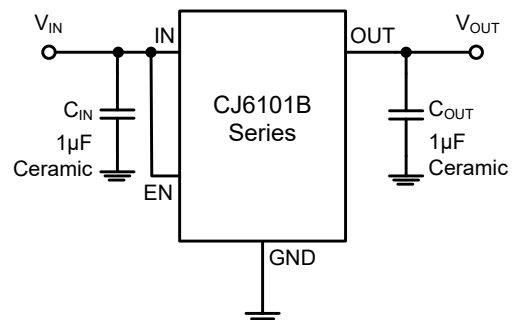

Figure 4-1. Typical Application Circuits

5 Orderable Information

MODEL	DEVICE	PACKAGE	OP TEMP	ECO PLAN	MSL	PACKING OPTION	SORT
3 Pins Packaged Products							
CJ6101-1.8	CJ6101A18M	SOT-23-3L	-40 ~ 85°C	RoHS & Green	Level 3 168 HR	Tape and Reel 3000 Units / Reel	Active
CJ6101-2.5	CJ6101A25M	SOT-23-3L	-40 ~ 85°C	RoHS & Green	Level 3 168 HR	Tape and Reel 3000 Units / Reel	Active
CJ6101-2.8	CJ6101A28M	SOT-23-3L	-40 ~ 85°C	RoHS & Green	Level 3 168 HR	Tape and Reel 3000 Units / Reel	Active
CJ6101-3.0	CJ6101A30M	SOT-23-3L	-40 ~ 85°C	RoHS & Green	Level 3 168 HR	Tape and Reel 3000 Units / Reel	Active
CJ6101-3.3	CJ6101A33M	SOT-23-3L	-40 ~ 85°C	RoHS & Green	Level 3 168 HR	Tape and Reel 3000 Units / Reel	Active
CJ6101-3.6	CJ6101A36M	SOT-23-3L	-40 ~ 85°C	RoHS & Green	Level 3 168 HR	Tape and Reel 3000 Units / Reel	Active
4 Pins Packaged Products							
CJ6101-1.8	CJ6101B18F	DFNWB1×1-4L	-40 ~ 85°C	RoHS & Green	Level 1 Infinite	Tape and Reel 10000 Units / Reel	Active
CJ6101-2.8	CJ6101B28F	DFNWB1×1-4L	-40 ~ 85°C	RoHS & Green	Level 1 Infinite	Tape and Reel 10000 Units / Reel	Active
CJ6101-3.0	CJ6101B30M	DFNWB1×1-4L	-40 ~ 85°C	RoHS & Green	Level 1 Infinite	Tape and Reel 10000 Units / Reel	Active
CJ6101-3.3	CJ6101B33M	DFNWB1×1-4L	-40 ~ 85°C	RoHS & Green	Level 1 Infinite	Tape and Reel 10000 Units / Reel	Active
5 Pins Packaged Products							
CJ6101-1.8	CJ6101B18M	SOT-23-5L	-40 ~ 85°C	RoHS & Green	Level 3 168 HR	Tape and Reel 3000 Units / Reel	Active
CJ6101-2.8	CJ6101B28M	SOT-23-5L	-40 ~ 85°C	RoHS & Green	Level 3 168 HR	Tape and Reel 3000 Units / Reel	Active
CJ6101-3.0	CJ6101B30M	SOT-23-5L	-40 ~ 85°C	RoHS & Green	Level 3 168 HR	Tape and Reel 3000 Units / Reel	Active
CJ6101-3.3	CJ6101B33M	SOT-23-5L	-40 ~ 85°C	RoHS & Green	Level 3 168 HR	Tape and Reel 3000 Units / Reel	Active
CJ6101-3.6	CJ6101B36M	SOT-23-5L	-40 ~ 85°C	RoHS & Green	Level 3 168 HR	Tape and Reel 3000 Units / Reel	Active

5 Orderable Information

MODEL	DEVICE	PACKAGE	OP TEMP	ECO PLAN	MSL	PACKING OPTION	SORT
Customized Products							
Output from 1.0V to 5.0V		SOT-23-3L	-40 ~ 85°C	RoHS & Green	Level 3 168 HR	Tape and Reel 3000 Units / Reel	Customized
		DFNWB1×1-4L	-40 ~ 85°C	RoHS & Green	Level 1 Infinite	Tape and Reel 10000 Units / Reel	Customized
		SOT-23-5L	-40 ~ 85°C	RoHS & Green	Level 3 168 HR	Tape and Reel 3000 Units / Reel	Customized
CJ6101-x.x	CJ6101AxxMC	SOT-23-3L	-40 ~ 85°C	RoHS & Green	Level 3 168 HR	Tape and Reel 3000 Units / Reel	Customized
	CJ6101AxxMY	SOT-23-3L	-40 ~ 85°C	RoHS & Green	Level 3 168 HR	Tape and Reel 3000 Units / Reel	Customized
	CJ6101AxxP	SOT-89-3L	-40 ~ 85°C	RoHS & Green	Level 3 168 HR	Tape and Reel 1000 Units / Reel	Customized
	CJ6101AxxPT	SOT-89-3L	-40 ~ 85°C	RoHS & Green	Level 3 168 HR	Tape and Reel 1000 Units / Reel	Customized
	CJ6101AxxPL	SOT-89-3L	-40 ~ 85°C	RoHS & Green	Level 3 168 HR	Tape and Reel 1000 Units / Reel	Customized
	CJ6101AxxMF	SOT-23-5L	-40 ~ 85°C	RoHS & Green	Level 3 168 HR	Tape and Reel 3000 Units / Reel	Customized
	CJ6101AxxMR	SOT-23-5L	-40 ~ 85°C	RoHS & Green	Level 3 168 HR	Tape and Reel 3000 Units / Reel	Customized
Others	-	-	-	-	-	-	Customized

Note:

ECO PLAN: For the RoHS and Green certification standards of this product, please refer to the official report provided by JSCJ.

MSL: Moisture Sensitivity Level. Determined according to JEDEC industry standard classification.

SORT: Specifically defined as follows:

Active: Recommended for new products;

Customized: Products manufactured to meet the specific needs of customers;

Preview: The device has been released and has not been fully mass produced. The sample may or may not be available;

NoRD: It is not recommended to use the device for new design. The device is only produced for the needs of existing customers;

Obsolete: The device has been discontinued.

6 Pin Configuration and Marking Information

6.1 Pin Configuration

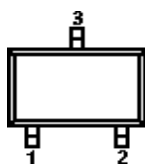

SOT-23-3L

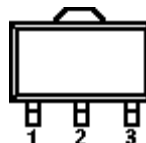

SOT-89-3L

PIN NAME	3 Pins SOT Series Packages					
	SOT-23-3L			SOT-89-3L		
	AxxM	AxxMC	AxxMY	AxxP	AxxPT	AxxPL
IN	3	1	2	2	3	1
GND	1	3	3	1	2	2
OUT	2	2	1	3	1	3

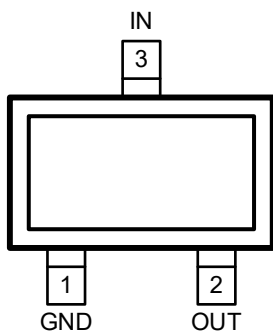

CJ6101AxxM
SOT-23-3L

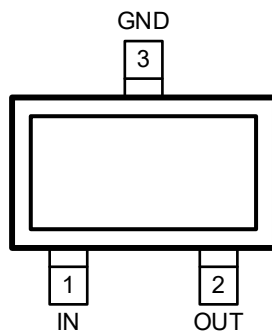

CJ6101AxxMC
SOT-23-3L

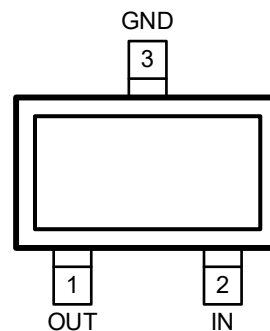

CJ6101AxxMY
SOT-23-3L

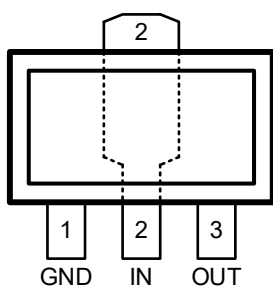

CJ6101AxxP
SOT-89-3L

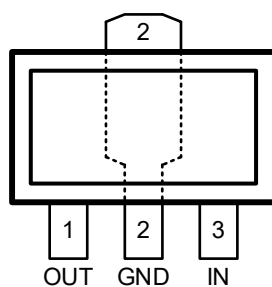

CJ6101AxxPT
SOT-89-3L

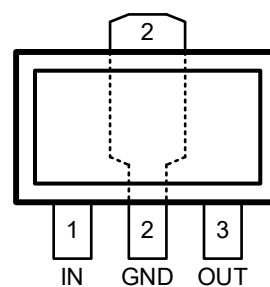

CJ6101AxxPL
SOT-89-3L

6 Pin Configuration and Marking Information

6.1 Pin Configuration and Function (continued)

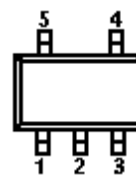
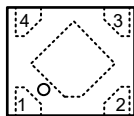

PIN NAME	DFN Series Packages	
	DFNWB1×1-4L	
	BxxF	
IN	4	
GND	2	
EN	3	
OUT	1	
-	Thermal Pad	

PIN NAME	5 Pins SOT Series Packages		
	SOT-23-5L		
	BxxM	AxxMF	AxxMR
IN	1	1	2
GND	2	2	1
EN	3	-	-
NC	4	3 & 4	4 & 5
OUT	5	5	3

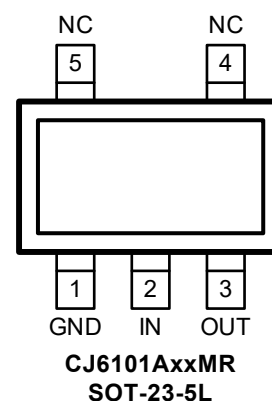
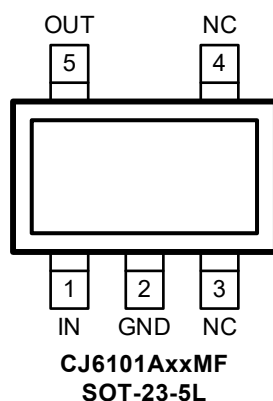
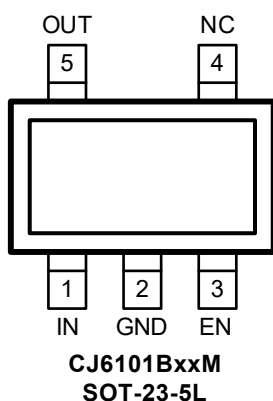
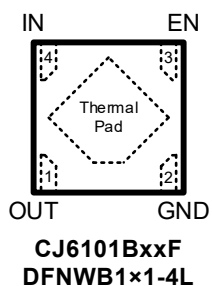

6 Pin Configuration and Marking Information

6.2 Pin Function

PIN NAME	I / O	CJ6101 Series Pin Function
		DESCRIPTION
IN	I	Input to the device. Use the recommended value of the input capacitor and place it as close to the IN and GND pins of the device as possible to help obtain the best transient response and minimize the input impedance.
GND	-	Regulator ground.
EN	I	Enable pin. Drive EN high level to enable the device, and drive EN low level to turn off the device. Do not float this pin. If not need, connect EN to IN.
NC	-	No internal connection. This pin can float, but when this pin is connected to GND, the device has better thermal performance.
OUT	O	Output of the regulator. An output capacitor needs to be placed between OUT and GND to maintain the stability of the device output. Use the capacitor with the recommended value and place it as close as possible to the OUT and GND pins of the device to help obtain the best transient response.
-	Thermal Pad	The thermal pad shall be fully welded to the board to improve the power dissipation performance of the package and reduce the conduction resistance.

6.3 Marking Information

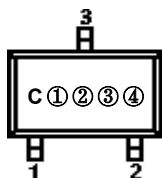

SOT-23-3L

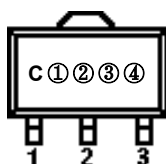

SOT-89-3L

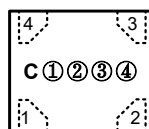

DFNWB×1-4L

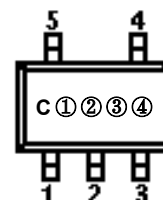

SOT-23-5L

CJ6101 Series Marking: C ① ② ③ ④							
DESIGNATOR	DESCRIPTION						
C	The serial number of this CJ6101 series.						
①	Representative output voltage. The rules are as follows:						
	1.8V: D	2.5V: E	2.8V: F	3.0V: G	3.3V: H	3.6V: I	5.0V: K
	Others: Customized.						
② & ③	Code for production.						
④	Product code with special pin arrangement sequence. The rules are as follows:						
	SOT-23-3L	M: Don't display	MC: C	MY: Y			
	SOT-89-3L	P: Don't display	PT: T	PL: L			
	SOT-23-5L	M: Don't display	MF: F	MR: R			
	DFNWB1×1-4L	F: Don't display	-	-			

7 Specifications

7.1 Absolute Maximum Ratings

($T_A = 25^\circ\text{C}$, unless otherwise specified)⁽¹⁾

CHARACTERISTIC		SYMBOL	VALUE	UNIT	
Input voltage range ⁽²⁾		V_{IN}	-0.3 ~ 7.0	V	
Enable pin input voltage range ⁽²⁾		V_{EN}	-0.3 ~ ($V_{IN} + 0.3$)		
Output voltage range ⁽²⁾		V_{OUT}	-0.3 ~ ($V_{IN} + 0.3$)		
Maximum power dissipation	CJ6101 series	SOT-23-3L	$P_{D\ Max}$	Internally Limited ⁽³⁾	W
		SOT-23-5L			
		SOT-89-3L			
		DFNWB1×1-4L			
Maximum junction temperature		$T_{J\ Max}$	125	$^\circ\text{C}$	
Storage temperature		T_{stg}	-40 ~ 125	$^\circ\text{C}$	
Soldering temperature & time		T_{solder}	260 $^\circ\text{C}$, 10s	-	

(1) Stresses beyond those listed under *Absolute Maximum Ratings* may cause permanent damage to the device. These are stress ratings only, which do not imply functional operation of the device at these or any other conditions beyond those indicated under *Recommended Operating Conditions*. Exposure to absolute maximum rated conditions for extended periods may affect device reliability.

(2) All voltages are with respect to network ground terminal.

(3) Refer to *Thermal Information* for details.

7.2 Recommended Operating Conditions

PARAMETER ⁽⁴⁾	SYMBOL	MIN.	NOM.	MAX.	UNIT
Input voltage	V_{IN}	1.8	-	6.0	V
Operating ambient temperature ⁽⁵⁾	T_A	-40	-	85	$^\circ\text{C}$

(4) JSCJ recommends that users should not exceed the rated value in the *Recommended Operating Conditions* for the application conditions of the device, so as to ensure the stability of normal operation and reliability of long-term operation. Operation beyond the recommended rated conditions does not mean that the product will fail. The consumers need to evaluate the risks that may be caused by the operation of the product beyond the recommended rated conditions.

(5) It is necessary to ensure that the operating junction temperature of the device does not exceed the rated value of the recommended operating conditions when using the device for design.

7 Specifications

7.3 ESD Ratings

ESD RATINGS		SYMBOL	VALUE	UNIT
Electrostatic discharge ⁽⁶⁾	Human body model	$V_{ESD-HBM}$	2000	V
	Machine model	V_{ESD-MM}	200	

(6) ESD testing is conducted in accordance with the relevant specifications formulated by the Joint Electronic Equipment Engineering Commission (JEDEC). The human body model (HBM) electrostatic discharge test is based on the JESD22-114D test standard, using a 100pF capacitor and discharging to each pin of the device through a resistance of 1.5kΩ. The electrostatic discharge test in mechanical model (MM) is based on the JESD22-115-A test standard and uses a 200pF capacitor to discharge directly to each pin of the device.

7.4 Thermal Information

THERMAL METRIC ⁽⁷⁾	SYMBOL	CJ6101 Series		UNIT
Junction-to-ambient thermal resistance	$R_{\theta JA}$	SOT-23-3L	SOT-89-3L	°C/W
		260.0	160.0	
		SOT-23-5L	DFNWB1×1-4L	
		250.0	220.0	
Reference maximum power dissipation for continuous operation	$P_{D Ref}$	SOT-23-3L	SOT-89-3L	W
		0.38	0.63	
		SOT-23-5L	DFNWB1×1-4L	
		0.40	0.45	

(7) $T_A = 25^{\circ}\text{C}$, see the part *Notes* for more information about thermal metrics.

7 Specifications

7.5 Electrical Characteristics

CJ6101 Series ($V_{IN} = V_{OUT} + 1V$, $C_{IN} = 1.0\mu F$, $C_{OUT} = 1.0\mu F$, $T_A = 25^\circ C$, unless otherwise specified)

CHARACTERISTIC	SYMBOL	TEST CONDITIONS		MIN.	TYP. ⁽⁸⁾	MAX.	UNIT
Input voltage	V_{IN}	-		1.8	-	6	V
DC output tolerance ⁽⁹⁾	-	$T_A = 25^\circ C$, $I_{OUT} = 1mA$		-2	-	+2	%
				-1 ⁽¹⁰⁾	-	+1 ⁽¹⁰⁾	
Output current	I_{OUT}	$T_J = 25^\circ C$		300	500	-	mA
Output current limit	$I_{OUT\ Limit}$	$V_{OUT} = 0.5 \times V_{OUT(Normal)}$, $V_{IN} = 5.0V$		350	550	750	mA
Quiescent current	I_Q	$I_{OUT} = 0mA$		-	0.8	1.5	μA
Dropout voltage	$V_{DO}^{(11)}$	$I_{OUT} = 100mA$	$V_{OUT} < 1.5V$	-	400	-	mV
			$V_{OUT} = 1.5\ to\ 2.0V$	-	200	-	
			$V_{OUT} > 2.0V$	-	110	-	
Line regulation	$LNR^{(12)}$	$V_{IN} = V_{OUT} + 1V\ to\ 6V$, $I_{OUT} = 10mA$		-	0.05	0.3	%/V
Load regulation	ΔV_{LOAD}	$V_{IN} = V_{OUT} + 1V$, $I_{OUT} = 1\ to\ 100mA$		-	10	-	mV
Output voltage temperature characteristics	-(13)	$I_{OUT} = 10mA$, $T_A = -40\ to\ 85^\circ C$		-	100	-	ppm/ $^\circ C$
Short current	I_{Short}	OUT short to GND		-	100	-	mA
Standby current	I_{STBY}	EN = GND		-	-	0.1	μA
Power supply rejection ratio	PSRR	$I_{OUT} = 50mA$, $V_{IN} = (V_{OUT} + 1V)_{DC} + 0.5V_{PPAC}$, $C_{IN} = 0\mu F$, $C_{OUT} = 1\mu F$	$f = 100Hz$	-	70	-	dB
			$f = 1kHz$	-	50	-	
			$f = 10kHz$	-	40	-	
			$f = 100kHz$	-	35	-	
EN high	V_{ENH}	$V_{IN} = V_{OUT} + 1V$		1.5	-	V_{IN}	V
EN low	V_{ENL}	$V_{IN} = V_{OUT} + 1V$		-	-	0.3	V
Thermal shutdown temperature	T_{SD}	-		-	160	-	$^\circ C$
Thermal shutdown hysteresis	ΔT_{SD}	-		-	20	-	$^\circ C$
Auto-discharge resistance	$R_{Discharge}$	$V_{IN} = 5V$, $V_{OUT} = 3.0V$, EN = GND		-	100	-	Ω

7 Specifications

7.5 Electrical Characteristics (continued)

Note:

- (8) Typical numbers are at 25°C and represent the most likely norm.
- (9) The effective output voltage range, which refers to the tolerance range that the output voltage may reach when the input voltage is equal to the output voltage plus 1V and the output current maintains a certain value.
- (10) Products with ±1% output tolerance can be customized.
- (11) Test the difference of output voltage and input voltage when input voltage is decreased gradually till output voltage equals to 98% of $V_{OUT\ Normal}$.
- (12) The line regulation is calculated by the following formula:

$$LNR = \frac{\Delta V_{OUT}}{V_{OUT} \times \Delta V_{IN}}$$

where, ΔV_{OUT} is the variation of the output voltage, ΔV_{IN} is the variation of the input voltage.

- (13) The output voltage temperature characteristics (TR) is calculated by the following formula:

$$TR = \frac{\Delta V_{OUT}}{V_{OUT} \times \Delta T}$$

where, ΔV_{OUT} is the variation of the output voltage, ΔT is the variation of the ambient temperature.

7.6 Typical Characteristics

CJ6101 Series ($C_{IN} = 1.0\mu F$, $C_{OUT} = 1.0\mu F$, $T_A = 25^\circ C$, unless otherwise specified)

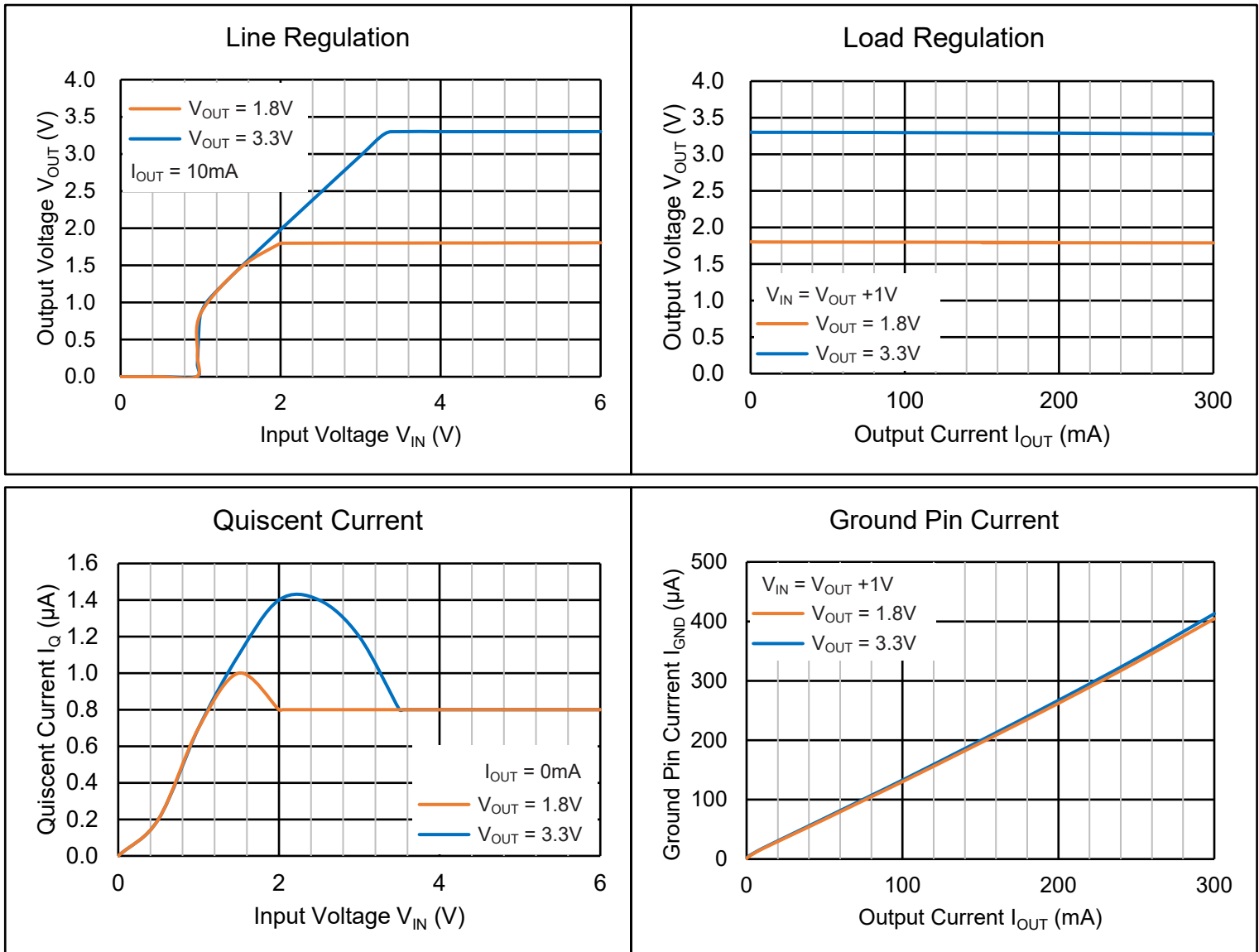

7 Specifications

7.6 Typical Characteristics (continued)

CJ6101 Series ($C_{IN} = 1.0\mu F$, $C_{OUT} = 1.0\mu F$, $T_A = 25^\circ C$, unless otherwise specified)

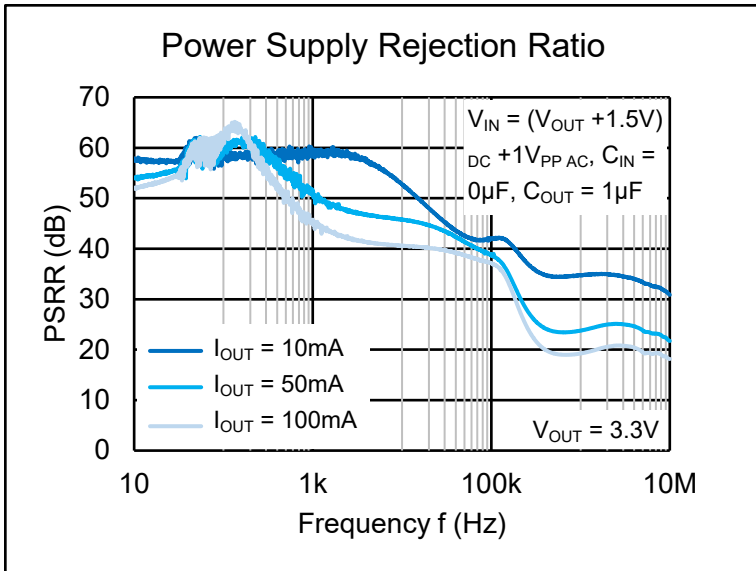
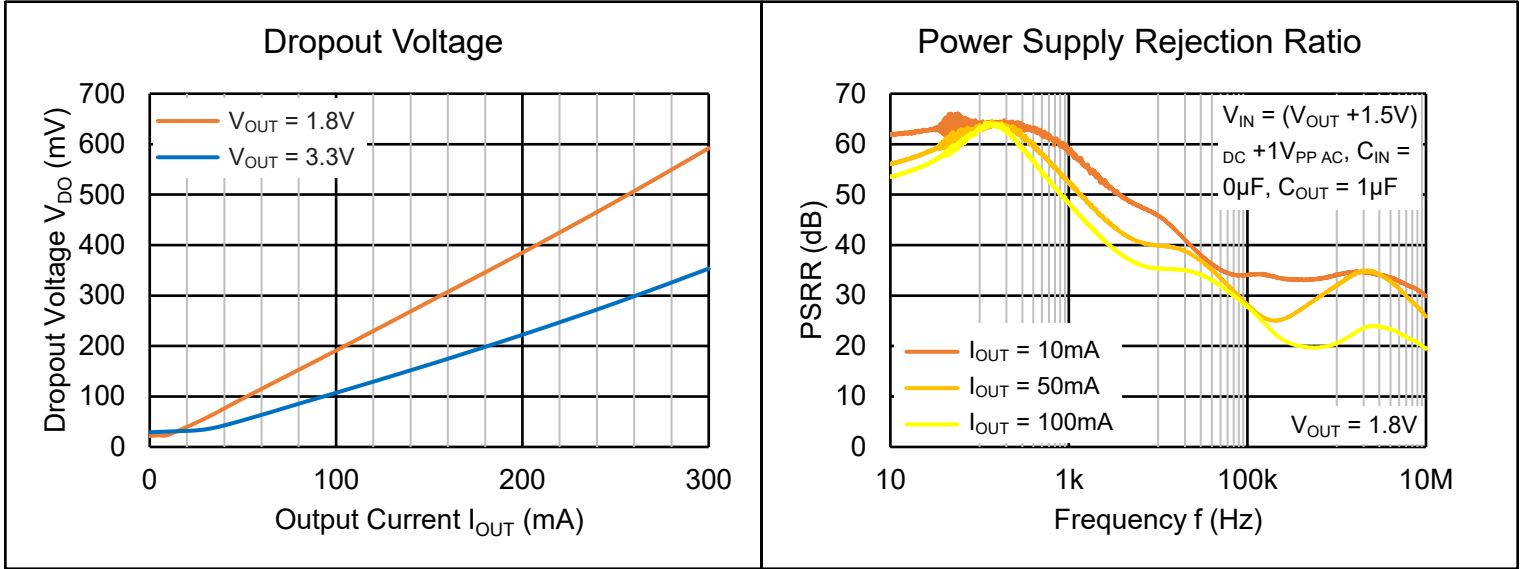

7 Specifications

7.6 Typical Characteristics (continued)

CJ6101 Series ($C_{IN} = 1.0\mu F$, $C_{OUT} = 1.0\mu F$, $T_A = 25^\circ C$, unless otherwise specified)

Load Transient

$V_{OUT} = 1.8V$, $V_{IN} = V_{EN} = V_{OUT} + 1V$, CH2: V_{OUT} , CH4: I_{OUT}

$I_{OUT} = 0 \sim 100mA$

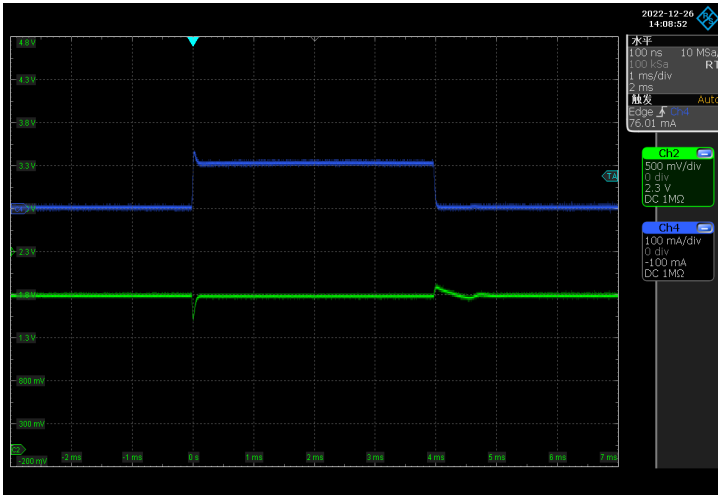

$I_{OUT} = 0 \sim 300mA$

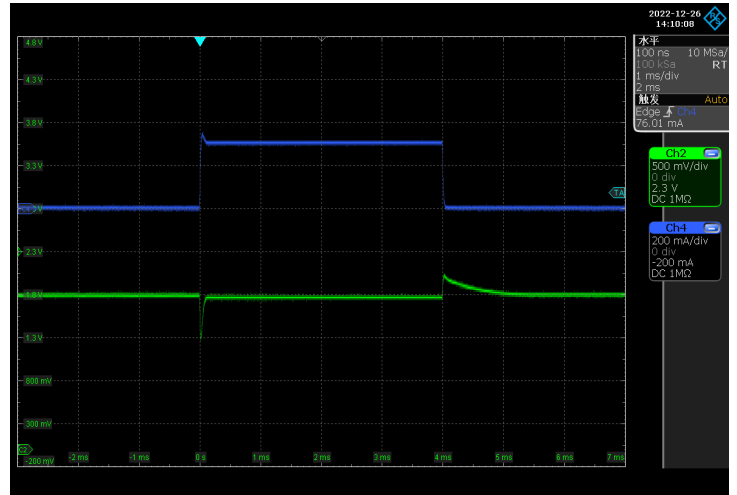

$I_{OUT} = 10 \sim 150mA$

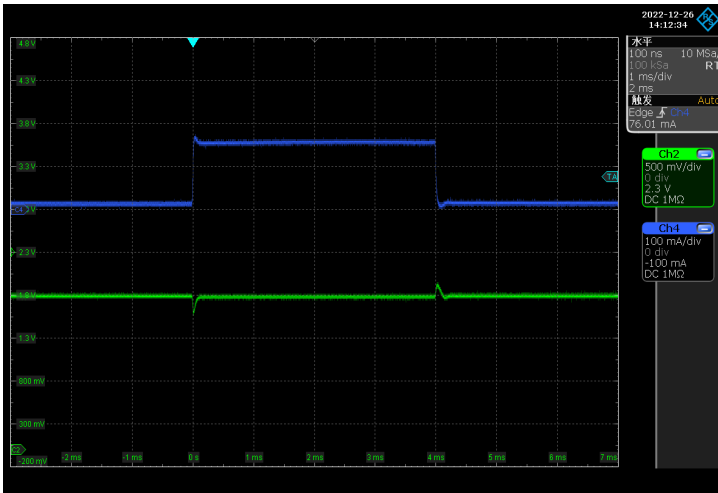

$I_{OUT} = 50 \sim 250mA$

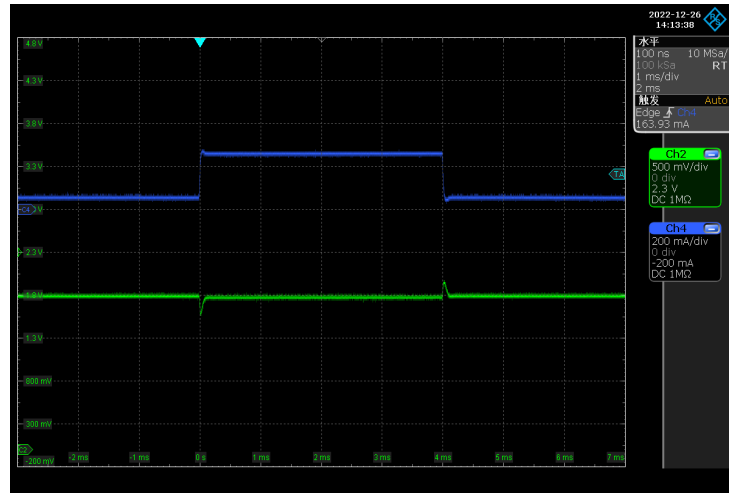

$V_{OUT} = 3.3V$, $V_{IN} = V_{EN} = V_{OUT} + 1V$, CH2: V_{OUT} , CH4: I_{OUT}

$I_{OUT} = 0 \sim 100mA$

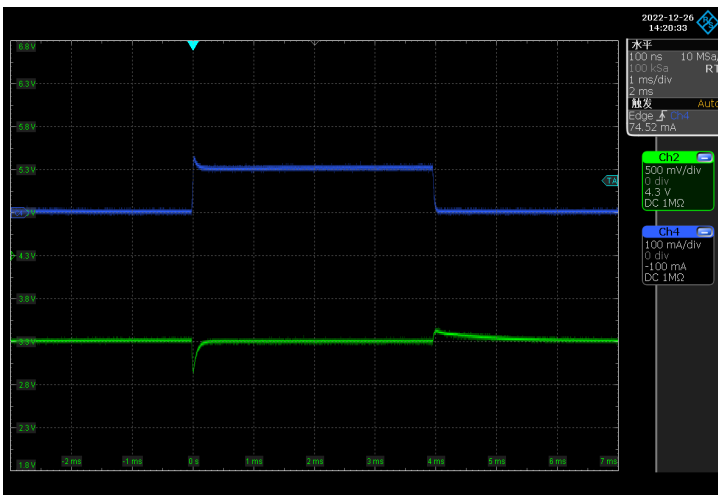

$I_{OUT} = 0 \sim 300mA$

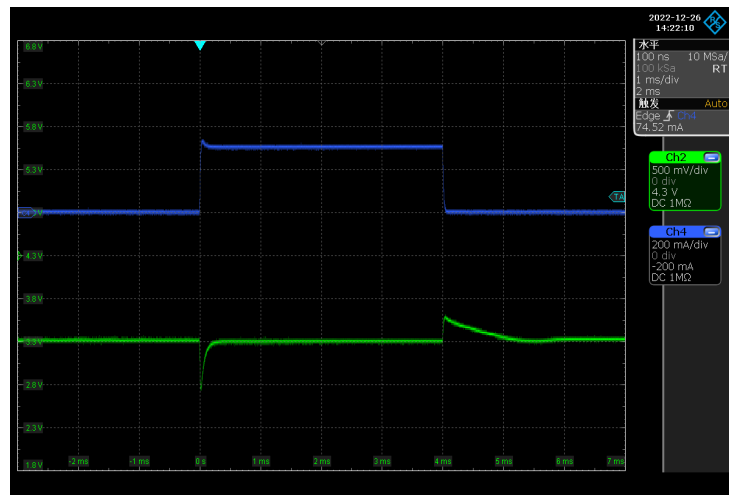

7 Specifications

7.6 Typical Characteristics (continued)

CJ6101 Series ($C_{IN} = 1.0\mu F$, $C_{OUT} = 1.0\mu F$, $T_A = 25^\circ C$, unless otherwise specified)

$I_{OUT} = 10 \sim 150mA$

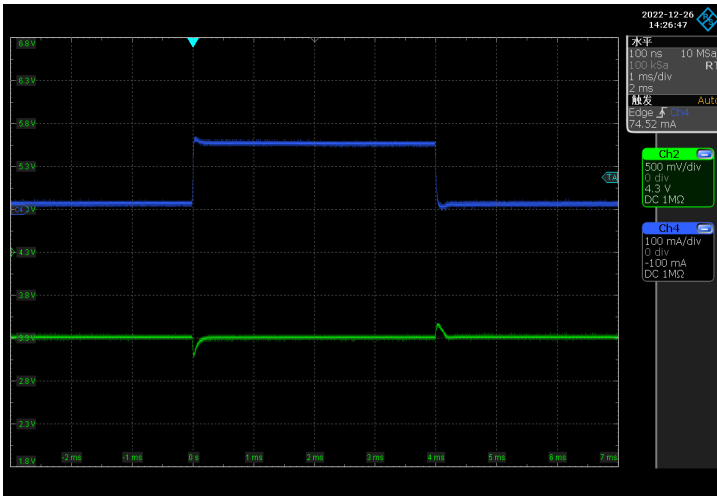

$I_{OUT} = 50 \sim 250mA$

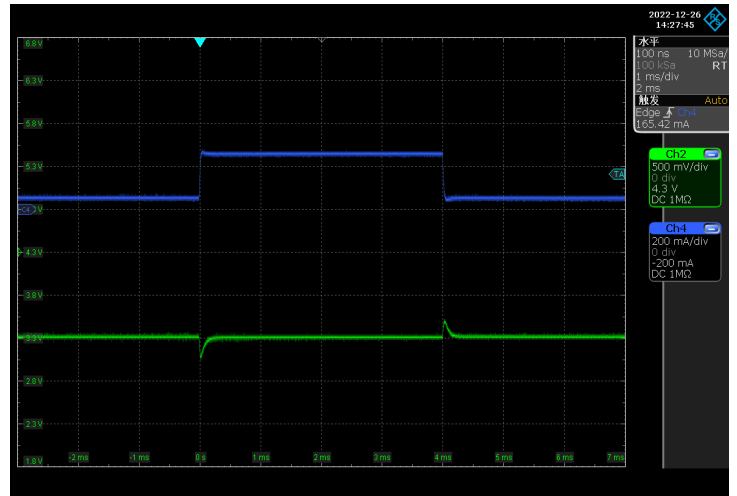

EN High & EN Low

$V_{IN} = V_{OUT} + 1V$, $V_{EN} = 0 \sim (V_{OUT} + 1)V$, $I_{OUT} = 0mA$, CH2: V_{OUT} , CH3: V_{EN}

$V_{OUT} = 1.8V$, EN High

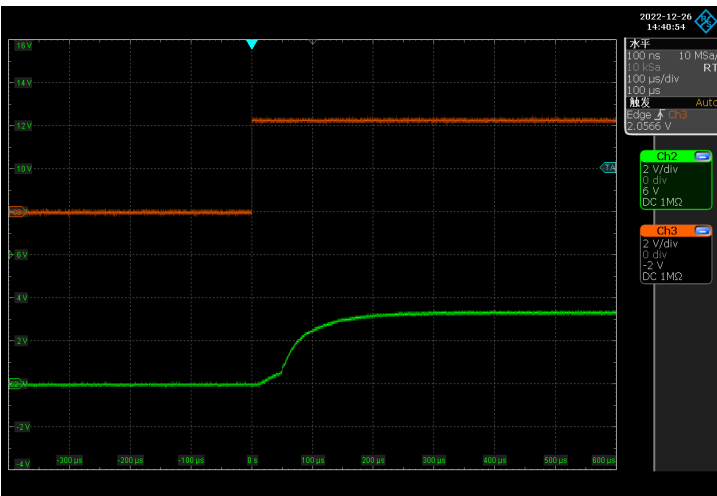

$V_{OUT} = 1.8V$, EN Low

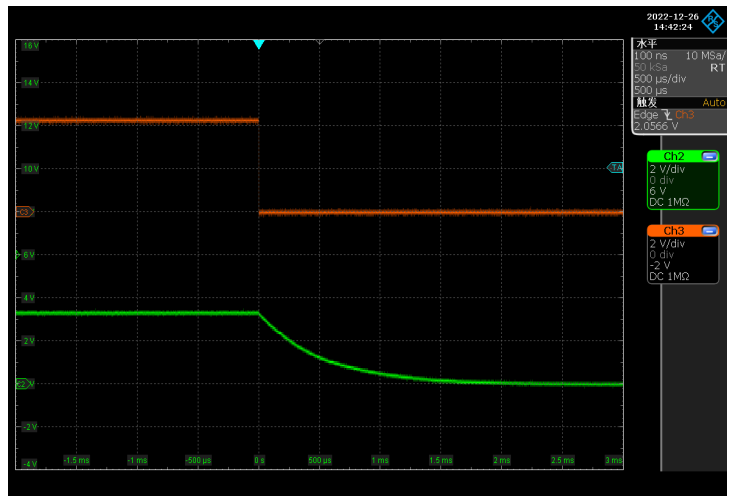

$V_{OUT} = 3.3V$, EN High

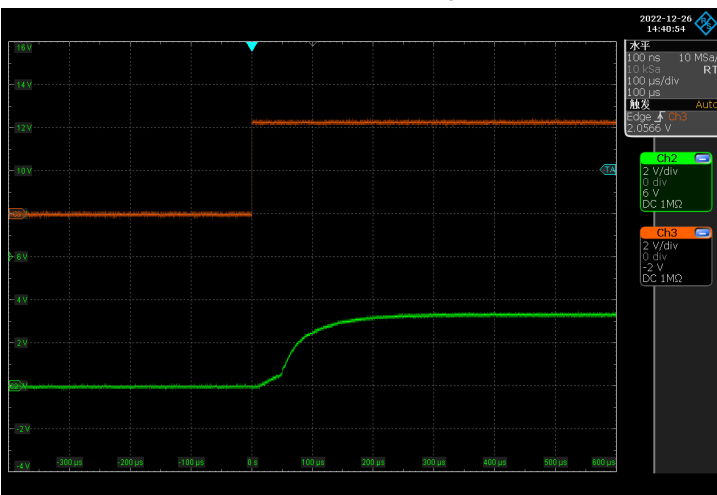

$V_{OUT} = 3.3V$, EN Low

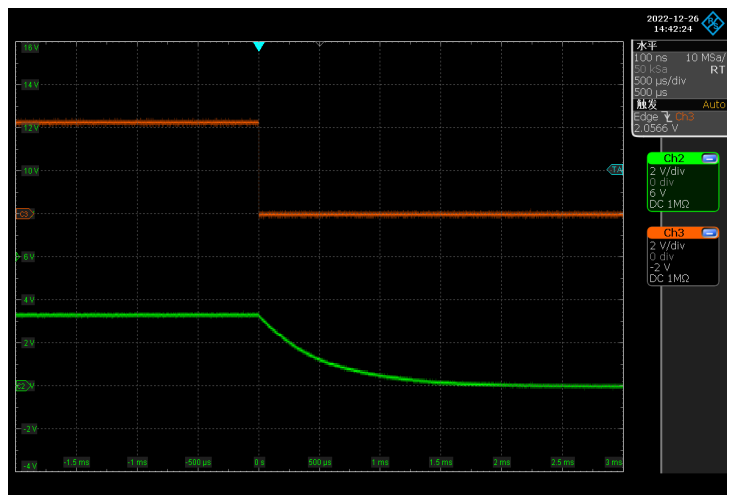

7 Specifications

7.6 Typical Characteristics (continued)

CJ6101 Series ($C_{IN} = 1.0\mu F$, $C_{OUT} = 1.0\mu F$, $T_A = 25^\circ C$, unless otherwise specified)

Short Circuit Protection

$V_{OUT} = 3.3V$, $V_{IN} = V_{EN} = V_{OUT} + 1V$, OUT short to GND, CH₂: V_{OUT} , CH₄: I_{OUT}

Short circuit protection trigger

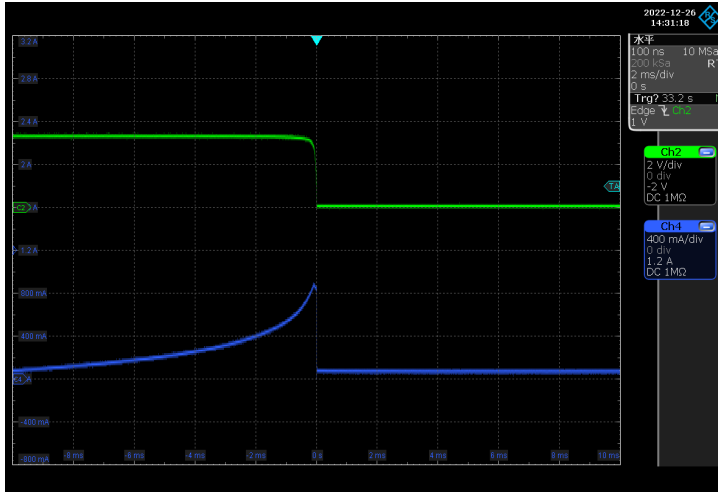

Short circuit protection release

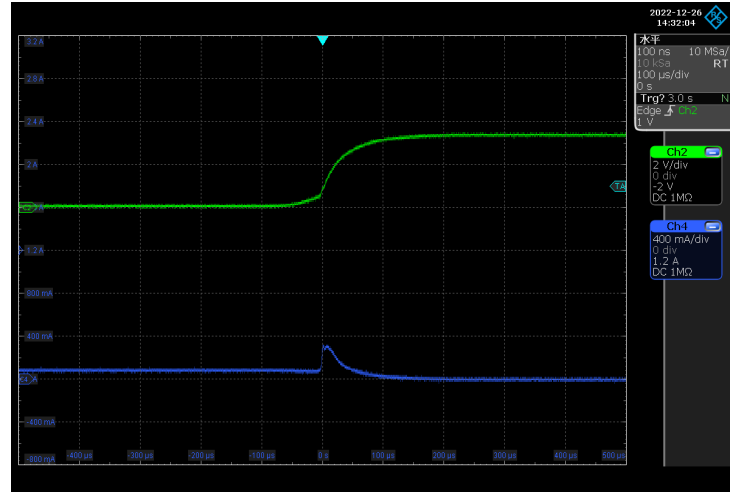

Power On

$V_{EN} = V_{IN}$, $V_{IN} = 0 \sim (V_{OUT} + 1)V$, CH₁: V_{IN} , CH₂: V_{OUT}

$V_{OUT} = 1.8V$, $I_{OUT} = 10mA$

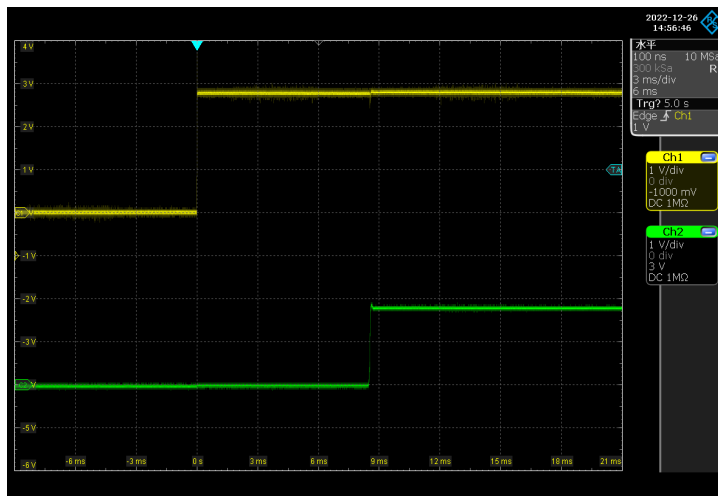

$V_{OUT} = 3.3V$, $I_{OUT} = 10mA$

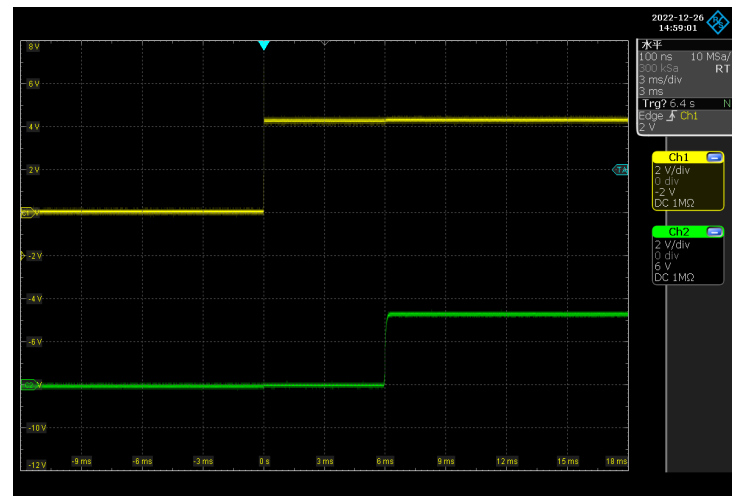

8 Detailed Description

8.1 Description

The CJ6101 series is a group of linear voltage regulators with ultra-low power consumption and low voltage difference. After optimization, it has excellent transient performance. These features make the device ideal for most battery powered applications. This low dropout linear regulator provides built-in current limiting, short circuit protection and thermal shutdown protection functions.

8.2 Functional Block Diagram

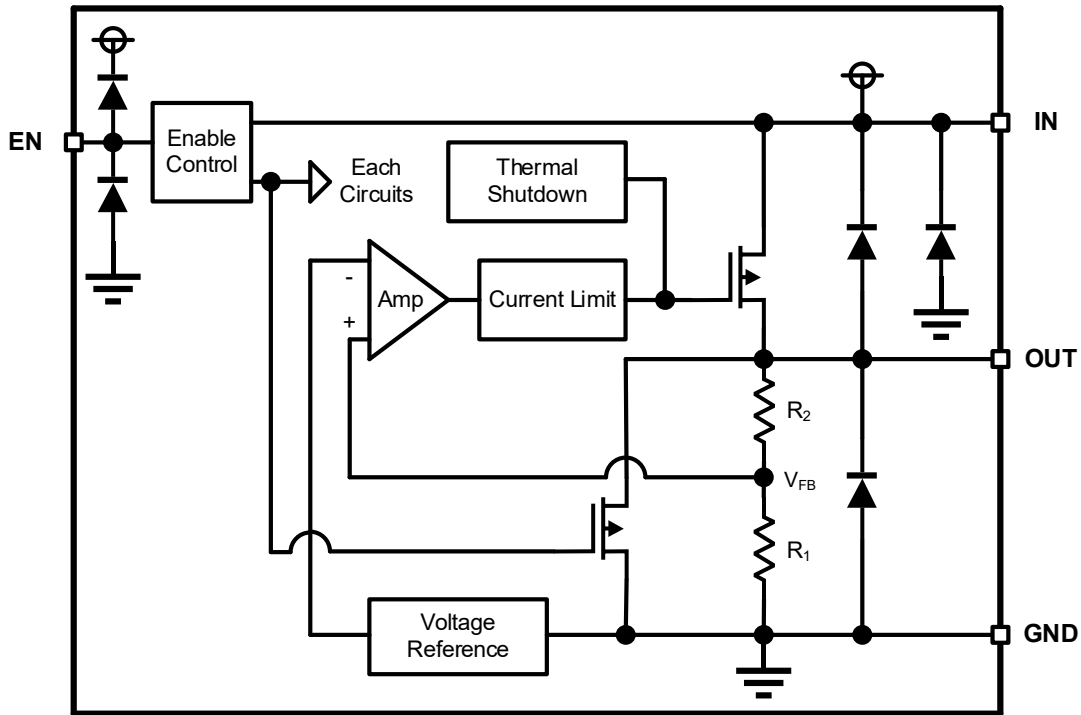

The internal feedback resistors R_1 and R_2 form a voltage divider circuit to compare the V_{FB} input error amplifier with the reference voltage. The internal regulator tube (PMOS) will control its conduction degree through the grid voltage provided by the error amplifier output, which will make the output voltage V_{OUT} not affected by temperature changes or input voltage changes to a certain extent, thus maintaining the stability of the device output voltage.

8 Detailed Description

8.3 Feature Description

Power Supply Input

When the input voltage is lower than the rated range of the data sheet, the device will lose the regulation function of stabilizing the output voltage, that is, it is unable to maintain the output voltage within the rated range. At this time, compared with normal operation, the quiescent current of the device may exceed the rated range, and the transient response performance may be seriously degraded.

When the input voltage is higher than the rated range of the data sheet, the device may cause irreversible damage or failure due to exceeding the maximum rated range of electrical stress.

For the rated input voltage of the device, see *Recommended Operating Conditions*.

Output Current

When the circuit design is appropriate, the CJ6101 series can reach the maximum load capacity of at least 300mA. According to the power dissipation of the package and the effective connection thermal resistance with the environment, selecting the appropriate package for the circuit design can make the device emit more heat energy.

Enable Control

The enable pin of the device (EN) is active at high level. When the voltage of the EN is greater than the EN logic high voltage ($V_{EN\ H}$), the device will be enabled and maintain the normal output. When the voltage of the EN is lower than the EN logic low voltage ($V_{EN\ L}$), the internal circuit of the device will be disabled and the output will be turned off, the device will be in the standby mode until EN is turned to high level again. The $V_{EN\ H}$ and $V_{EN\ L}$ can be found in the *Electrical Characteristics*.

Normal startup waveform and startup slope rate control can be ensured when the device starts from any low voltage lower than $V_{EN\ L}$, but the discharge time of output capacitor must be taken into account. EN can not be float, if EN is not required to control the output voltage independently, connect EN to IN.

Dropout Voltage

Dropout voltage (V_{DO}) refers to the minimum voltage difference between input and output ($V_{IN} - V_{OUT}$) to make the device output voltage reach the rated range at rated current. When the dropout voltage condition required by the device is reached, the internal MOSFET will be fully turned on, at this time, the MOSFET is equivalent to a switch for regulation.

The V_{DO} increases with the increase of load current. Since $V_{IN} - V_{OUT}$ must be no less than the V_{DO} , the V_{DO} indirectly specifies the minimum input voltage of devices under different load current conditions. If the $V_{IN} - V_{OUT}$ is less than the V_{DO} , the performance of the device may deteriorate (see *Operation in Dropout Mode* for details)..

Auto-discharge Function

The device has an automatic discharge mechanism. When the enabling control of the device is turned off, a pull-down MOSFET inside the device (see *Functional Block Diagram*) will connect a resistor to the ground to release the charge in the output capacitor, so as to turn off the whole device circuit. Refer to *Electrical Characteristics* for the value of automatic discharge resistance ($R_{Discharge}$). Do not rely on the active discharge circuit for discharging a large amount of output capacitance after the input supply has collapsed because reverse current can possibly flow from the output to the input. This reverse current flow can cause damage to the device. Limit reverse current to no more than 5% of the device rated current for a short period of time.

8 Detailed Description

8.3 Feature Description (continued)

Built-in Current Limit & Short Circuit Protection

The CJ6101 series has an internal current limiting circuit, which can protect the device by limiting the load current value in case of instantaneous high load current. When the current limiting is triggered, the output voltage is not regulated. If the out pin of the regulator is short circuited, the internal current limiting circuit will be triggered, the output current of the device will maintain at a relatively small value to protect the device. The typical value of short current I_{short} can be found in *Electrical Characteristics*. The current limiting state will continue until the load current drops to the normal range.

When the load current of the device is large, the device will generate more heat due to the increase of power consumption, which may cause the device to turn off its output due to the internal thermal shutdown protection before the current limit is triggered.

In order to ensure the normal operation of current limit, the inductance of input and load shall be minimized. Continuous operation under current limit is not recommended.

The current limit mode of the CJ6101 series is fold-back current limit. Using electronic load to test the starting characteristics may cause the device to fail to start normally.

Thermal Shutdown

The CJ6101 series has thermal shutdown protection mechanism. When the junction temperature (T_J) of the internal main channel MOSFET exceeds the thermal shutdown threshold temperature (T_{SD}), thermal shutdown will be triggered. At this time, the output will be turned off to prevent catastrophic damage to the chip due to accidental heating. When the T_J drops to a certain range of thermal shutdown threshold temperature (ΔT_{SD}), the thermal shutdown will be released and the device will return to the normal output. The temperature threshold of device triggering thermal shutdown (T_{SD}) and temperature range to be lowered to released from thermal shutdown (ΔT_{SD}) can be found in the *Electrical Characteristics*.

To ensure reliable operation, please limit the junction temperature to the specified range of *Recommended Operating Conditions* in the data sheet. Applications that exceed the recommended temperature range may cause the device to exceed its operating specifications.

Although the internal protection circuit of the device is designed to prevent overall thermal conditions, it is not intended to replace proper power dissipation. Running the device continuously until thermal shutdown or higher than the recommended operating T_J will reduce long-term reliability.

9 Application and Implementation

9.1 Typical Application Circuit

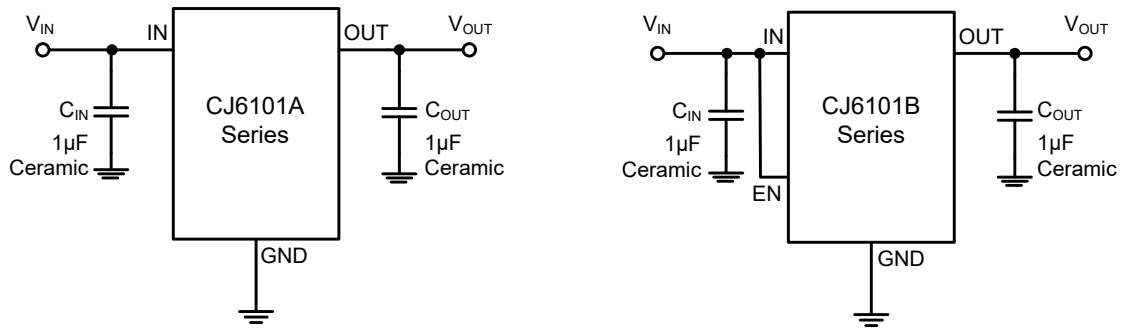

9.2 Application Information

Selection of Bypass Capacitances

It is recommended to use 1µF input and output ceramic capacitors to keep the device stable, and the position of the capacitor should be as close to the pin of the chip as possible.

Ceramic capacitors with low equivalent series resistance (ESR) are recommended. In such application scenarios, chip multilayer ceramic capacitor (MLCC) is a good choice, but the appropriate type of capacitor must be selected. Ceramic capacitors with X7R-, X5R- and C0G- rated dielectric materials can provide relatively good capacitance stability for the equipment in the temperature range. However, due to the large change of Y5V- capacitance value, Y5V- capacitor is not recommended. However, no matter which kind of ceramic capacitor is selected, the effective capacitance may vary with the working voltage and temperature.

In general, the use of appropriate input capacitors can help offset reactive input sources and improve transient response, input ripple and PSRR. If the power impedance is greater than 0.5Ω, it is recommended to use input capacitors. Higher value capacitors may be required if large, fast rise time load or line transients are expected, or if the device is located a few inches from the input power supply.

Also, the dynamic performance of the device can be improved by using a suitable output capacitor.

Transient Response

Transient response refers to the change of system output from initial state to stable state under the action of typical signal input. For LDO, the designer should pay attention to the possible impact of linear transient response and load transient response on the system: linear transient response refers to the transient response of output to change when the input voltage changes, while load transient response refers to the transient response of output to change when the output current changes. The specific phenomenon is that the output voltage of the device will have a short spike, especially when the input voltage or output current changes greatly in a short time. This change is not only related to the performance of the chip itself, but also related to the change of output current, change rate and output capacitance:

1. When the output current increases, the output voltage of the device will decrease to a certain extent, and the larger output current will provide a higher current discharge path for the output capacitor, which will affect the peak value generated by the transient spike and reduce the peak value;
2. The output current or input voltage changes relatively slowly, and the output change of the device is relatively small, affecting the spike caused by the change;
3. The use of large input and output capacitors can reduce the spike caused by transient response to a certain extent to improve the transient performance, but large output capacitors can also affect the response time of devices.

For the selection of bypass capacitance value, refer to the *Section of Bypass Capacitances* selection.

9 Application and Implementation

9.2 Application Information (continued)

Operation in Dropout Mode

The CJ6101 series is internally integrated with a P-MOSFET to achieve low dropout voltage. The voltage difference between the input and the output ($V_{IN} - V_{OUT}$) of the device must not be lower than the corresponding dropout voltage (V_{DO}) to ensure that the output voltage tolerance is within the rated range of the data sheet. The dropout voltage will increase with the increase of load current. When the $V_{IN} - V_{OUT}$ is less than the V_{DO} , the P-MOSFET inside the device is in a linear state, the resistance from the input pin to the output pin is equal to the resistance from the drain to the source of the P-MOSFET, and the device functions like a resistor. When operating in this state, the response time of the error amplifier inside the device will be limited, which will seriously degrade the transient performance of the device, when the external circuit has a transient change, the deviation of the output voltage will become larger than the normal operating state. In addition, the PSRR and noise performance of the device will be worse than that under normal operating conditions.

Recommended Continuous Operating Areas

As an LDO, the working area of CJ6101 series is limited by dropout voltage, output current, junction temperature and input voltage under continuous working condition. The recommended areas for continuous operation are shown in Figure 9-1:

- A. The LDO input and output voltage difference $V_{IN} - V_{OUT}$ must meet the dropout voltage V_{DO} conditions. See *Dropout Voltage* for more details.
- B. Rated output current range I_{RATED} .
- C. The actual junction temperature T_J of LDO shall not exceed the rated junction temperature. The product of voltage difference and current at both ends of LDO is power consumption, which determines the actual working junction temperature of LDO, so the curve is not linear.

In addition, the working area of CJ6101 series is limited by the rated $V_{IN MIN}$ and $V_{IN MAX}$.

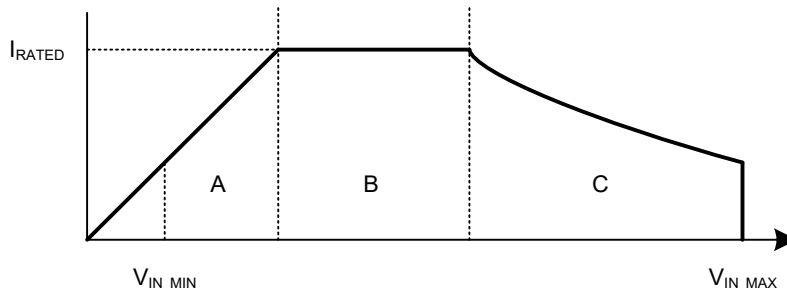

Figure 9-1. Region Description for Continuous Operation

NOTE

The application information in this section is not part of the data sheet component specification, and JSCJ makes no commitment or statement to guarantee its accuracy or completeness. Customers are responsible for determining the rationality of corresponding components in their circuit design and making tests and verifications to ensure the normal realization of their circuit design.

10 Mechanical Information

10.1 SOT-23-3L Mechanical Information

SOT-23-3L Outline Dimension

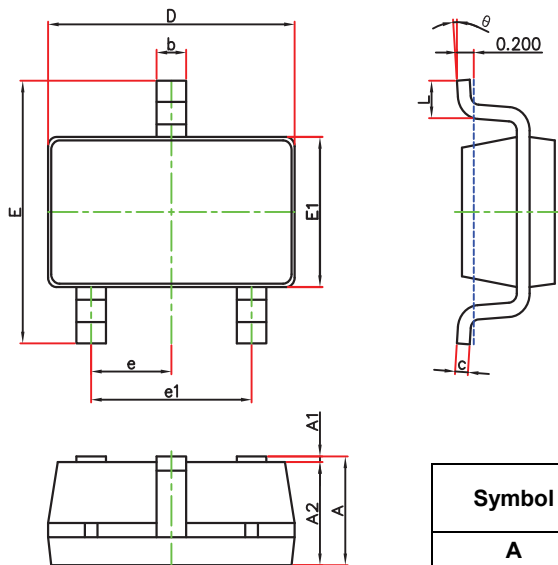

Symbol	Dimensions In Millimeters		Dimensions In Inches	
	Min.	Max.	Min.	Max.
A	1.050	1.250	0.041	0.049
A1	0.000	0.100	0.000	0.004
A2	1.050	1.150	0.041	0.045
b	0.300	0.500	0.012	0.020
c	0.100	0.200	0.004	0.008
D	2.820	3.020	0.111	0.119
E	2.650	2.950	0.104	0.116
E1	1.500	1.700	0.059	0.067
e	0.950(BSC)		0.037(BSC)	
e1	1.800	2.000	0.071	0.079
L	0.300	0.600	0.012	0.024
θ	0°	8°	0°	8°

SOT-23-3L Suggested Pad Layout

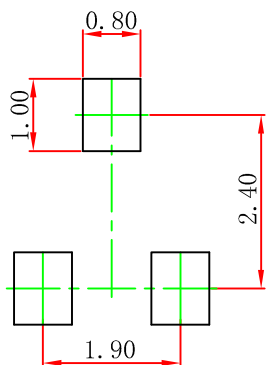

Note:

1. Controlling dimension: in millimeters.
2. General tolerance: ±0.05mm.
3. The pad layout is for reference purpose only.

10 Mechanical Information

10.2 SOT-89-3L Mechanical Information

SOT-89-3L Outline Dimensions

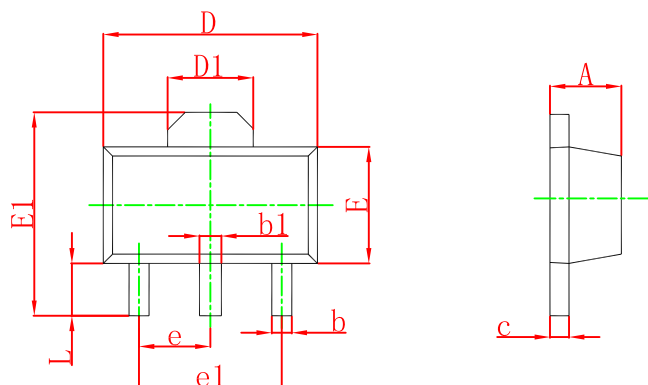

Symbol	Dimensions In Millimeters		Dimensions In Inches	
	Min.	Max.	Min.	Max.
A	1.400	1.600	0.055	0.063
b	0.320	0.520	0.013	0.197
b1	0.400	0.580	0.016	0.023
c	0.350	0.440	0.014	0.017
D	4.400	4.600	0.173	0.181
D1	1.550 REF		0.061 REF	
E	2.300	2.600	0.091	0.102
E1	3.940	4.250	0.155	0.167
e	1.500 TYP		0.060 TYP	
e1	3.000 TYP		0.118 TYP	
L	0.900	1.200	0.035	0.047

SOT-89-3L Suggested Pad Layout

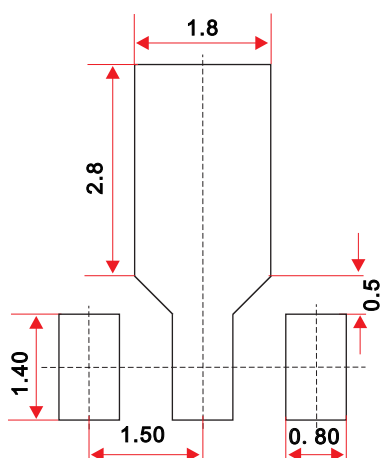

Note:

1. Controlling dimension: in millimeters.
2. General tolerance: $\pm 0.05\text{mm}$.
3. The pad layout is for reference purpose only.

10 Mechanical Information

10.3 DFNWB1×1-4L Mechanical Information

DFNWB1×1-4L Outlines Dimensions

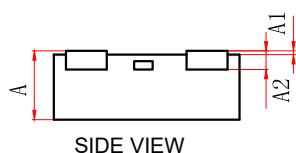
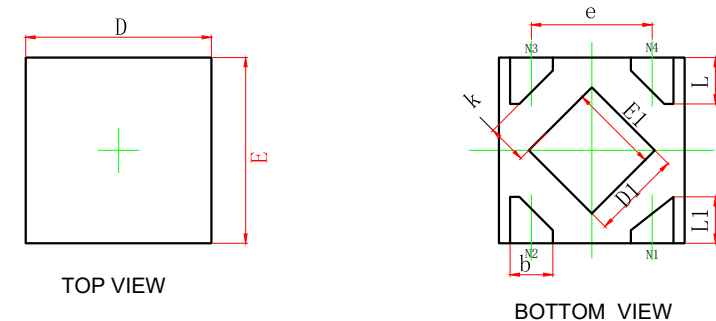

Symbol	Dimensions In Millimeters		Dimensions In Inches	
	Min.	Max.	Min.	Max.
A	0.320	0.400	0.013	0.016
A1	0.000	0.050	0.000	0.002
A2	0.100 REF.		0.004 REF.	
D	0.950	1.050	0.037	0.041
E	0.950	1.050	0.037	0.041
D1	0.430	0.530	0.017	0.021
E1	0.430	0.530	0.017	0.021
k	0.150MIN.		0.006MIN.	
b	0.180	0.280	0.007	0.011
e	0.650TYP.		0.026TYP.	
L	0.200	0.300	0.008	0.012
L1	0.200	0.300	0.008	0.012

DFNWB1×1-4L Suggested Pad Layout

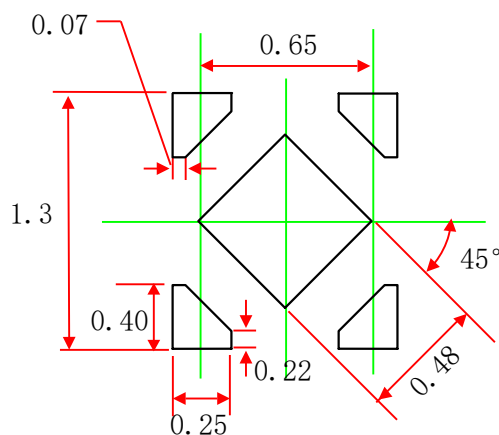

Note:

1. Controlling dimension: in millimeters.
2. General tolerance: $\pm 0.05\text{mm}$.
3. The pad layout is for reference purpose only.

10 Mechanical Information

10.4 SOT-23-5L Mechanical Information

SOT-23-5L Outline Dimensions

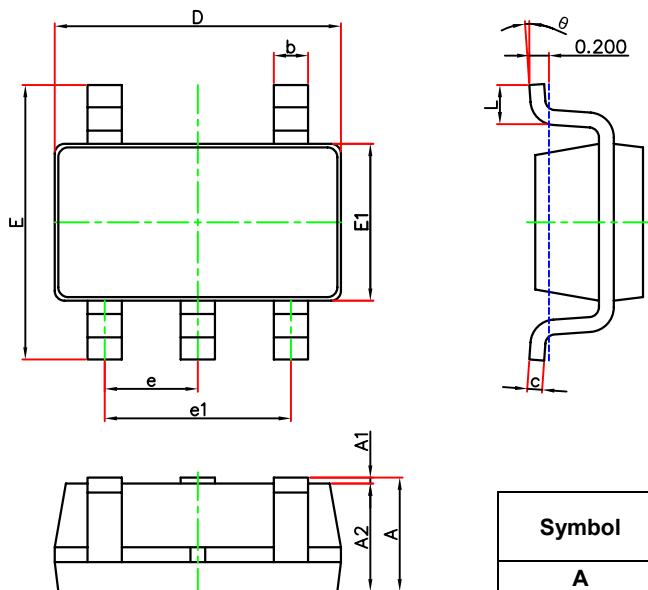

Symbol	Dimensions In Millimeters		Dimensions In Inches	
	Min.	Max.	Min.	Max.
A	1.050	1.250	0.041	0.049
A1	0.000	0.100	0.000	0.004
A2	1.050	1.150	0.041	0.045
b	0.300	0.500	0.012	0.020
c	0.100	0.200	0.004	0.008
D	2.820	3.020	0.111	0.119
E	2.650	2.950	0.104	0.116
E1	1.500	1.700	0.059	0.067
e	0.950(BSC)		0.037(BSC)	
e1	1.800	2.000	0.071	0.079
L	0.300	0.600	0.012	0.024
θ	0°	8°	0°	8°

SOT-23-5L Suggested Pad Layout

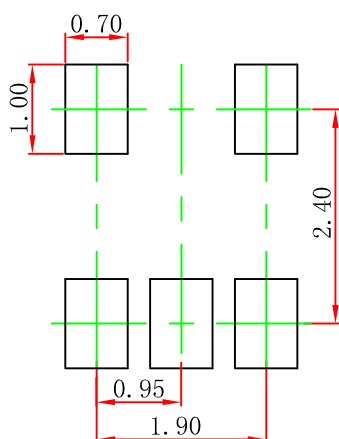

Note:

1. Controlling dimension: in millimeters.
2. General tolerance: ±0.05mm.
3. The pad layout is for reference purpose only.

11 Packaging Information

11.1 SOT-23-3L Tape and Reel Information

SOT-23-3L Embossed Carrier Tape

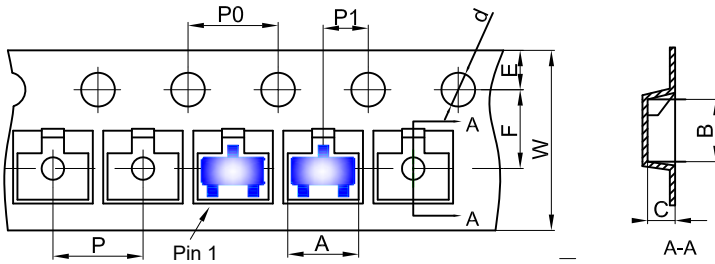

Packaging Description:

SOT-23-3L parts are shipped in tape. The carrier tape is made from a dissipative (carbon filled) polycarbonate resin. The cover tape is a multilayer film (Heat Activated Adhesive in nature) primarily composed of polyester film, adhesive layer, sealant, and anti-static sprayed agent. These reeled parts in standard option are shipped with 3,000 units per 7" or 18.0cm diameter reel. The reels are clear in color and is made of polystyrene plastic (anti-static coated).

Dimensions are in millimeter										
Pkg type	A	B	C	d	E	F	P0	P	P1	W
SOT-23-3L	3.18	3.28	1.32	Ø1.50	1.75	3.50	4.00	4.00	2.00	8.00

SOT-23-3L Tape Leader and Trailer

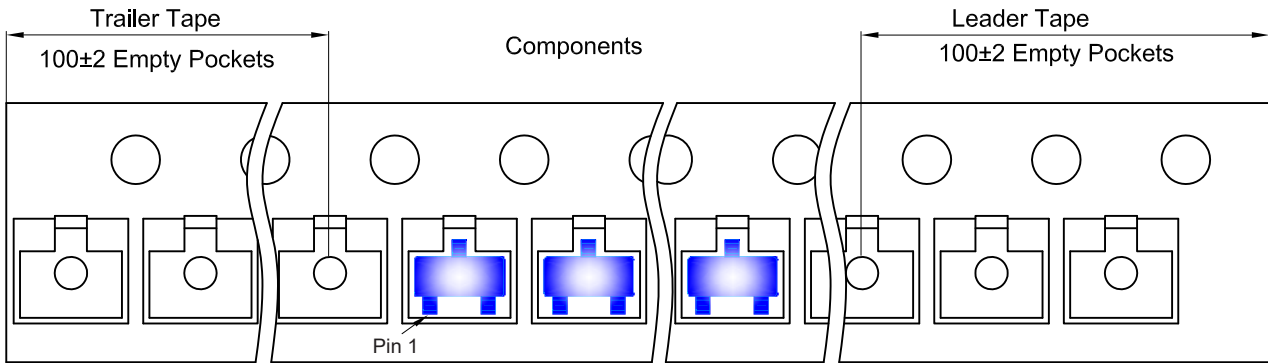

SOT-23-3L Reel

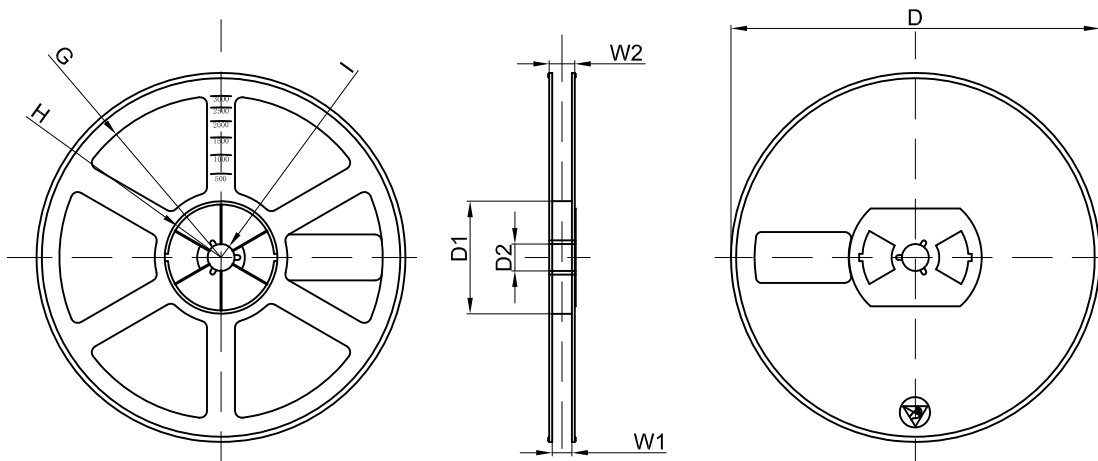

Dimensions are in millimeter								
Reel Option	D	D1	D2	G	H	I	W1	W2
7"Dia	Ø180.00	60.00	13.00	R78.00	R25.60	R6.50	9.50	13.10

REEL	Reel Size	Box	Box Size(mm)	Carton	Carton Size(mm)	G.W.(kg)
3000 pcs	7 inch	30,000 pcs	203×203×195	120,000 pcs	438×438×220	

11 Packaging Information

11.2 SOT-89-3L Tape and Reel Information

SOT-89-3L Embossed Carrier Tape

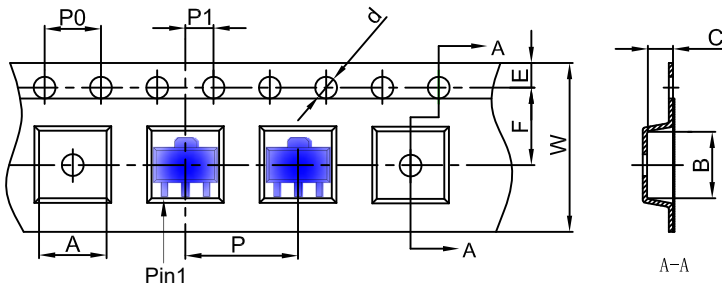

Packaging Description:
 SOT-89-3L parts are shipped in tape. The carrier tape is made from a dissipative (carbon filled) polycarbonate resin. The cover tape is a multilayer film (Heat Activated Adhesive in nature) primarily composed of polyester film, adhesive layer, sealant, and anti-static sprayed agent. These reeled parts in standard option are shipped with 1,000 units per 7" or 18.0 cm diameter reel. The reels are clear in color and is made of polystyrene plastic (anti-static coated).

Dimensions are in millimeter										
Pkg type	A	B	C	d	E	F	P0	P	P1	W
SOT-89-3L	4.85	4.45	1.85	Ø1.50	1.75	5.50	4.00	8.00	2.00	12.00

SOT-89-3L Tape Leader and Trailer

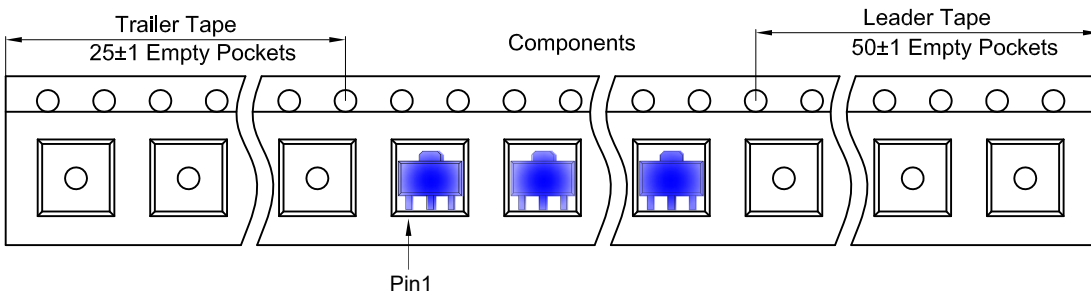

SOT-89-3L Reel

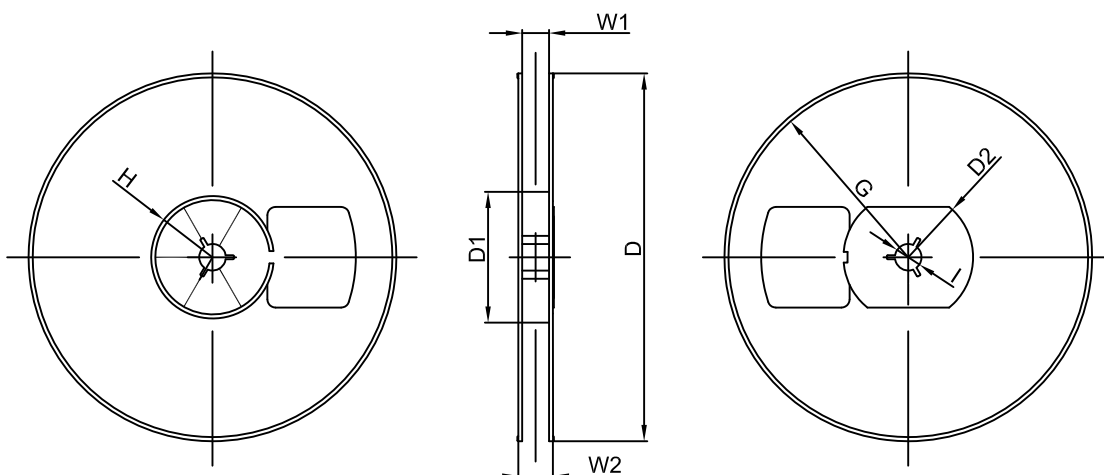

Dimensions are in millimeter								
Reel Option	D	D1	D2	G	H	I	W1	W2
7" Dia	Ø180.00	60.00	R32.00	R86.50	R30.00	Ø13.00	13.20	16.50

REEL	Reel Size	Box	Box Size(mm)	Carton	Carton Size(mm)	G.W.(kg)
1000 pcs	7 inch	10,000 pcs	203×203×195	40,000 pcs	438×438×220	

11 Packaging Information

11.3 DFNWB1×1-4L Tape and Reel Information

DFNWB1×1-4L Embossed Carrier Tape

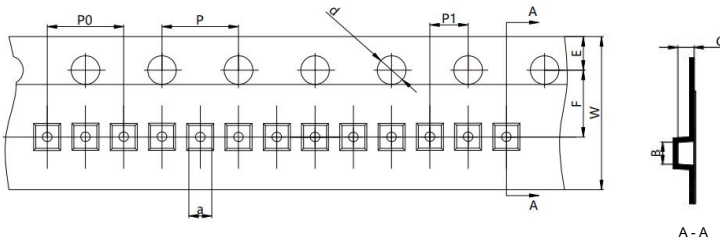

Packaging Description:

DFNWB1×1-4L parts are shipped in tape. The carrier tape is made from a dissipative (carbon filled) polycarbonate resin. The cover tape is a multilayer film (Heat Activated Adhesive in nature) primarily composed of polyester film, adhesive layer, sealant, and anti-static sprayed agent. These reeled parts in standard option are shipped with 3,000 units per 7" or 18.0cm diameter reel. The reels are clear in color and is made of polystyrene plastic (anti-static coated).

Dimensions are in millimeter										
Pkg type	a	B	C	d	E	F	P0	P	P1	W
DFNWB1×1-4L	1.12	1.13	0.50	1.55	1.75	3.5	4.00	4.00	2.00	8.00

DFNWB1×1-4L Tape Leader and Trailer

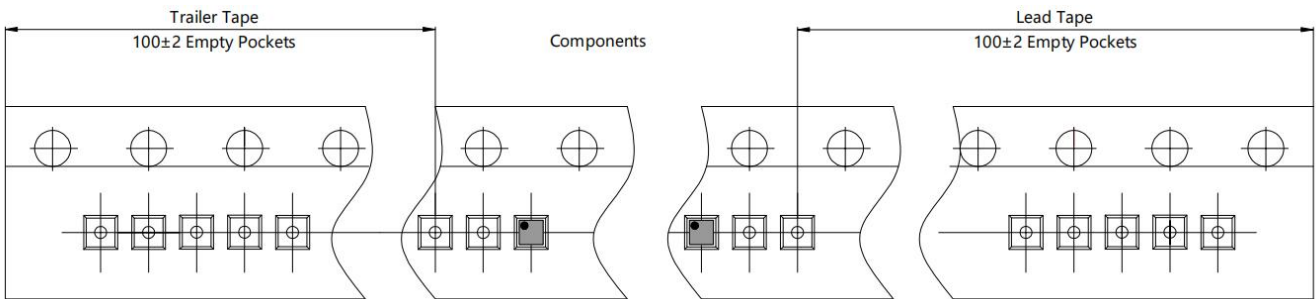

DFNWB1×1-4L Reel

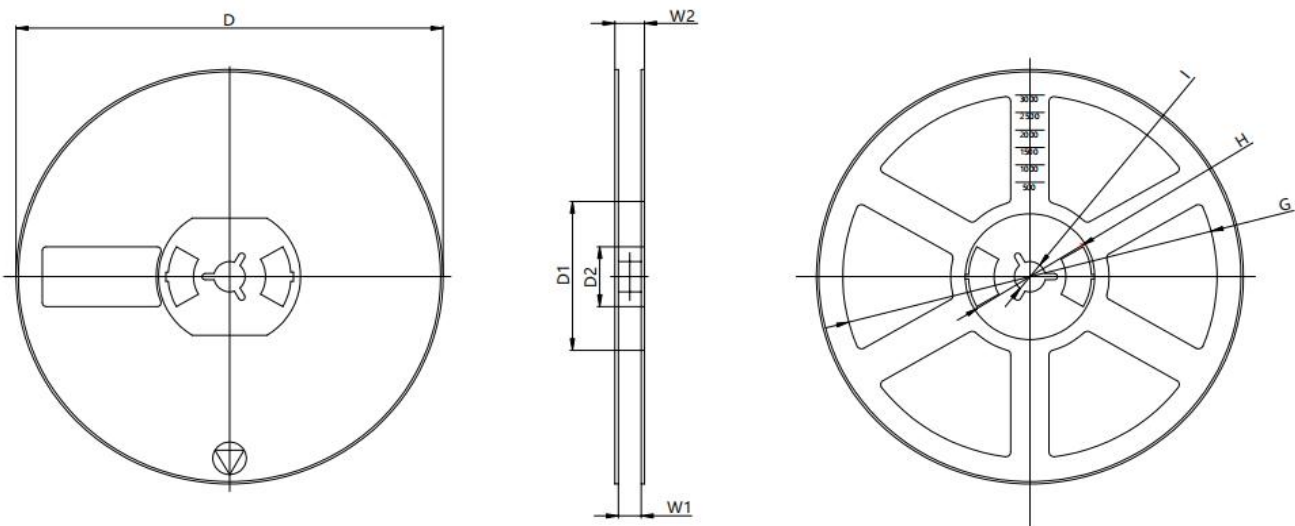

Dimensions are in millimeter								
Reel Option	D	D1	D2	G	H	I	W1	W2
7" Dia	∅ 178.00	54.5	13.5	R78.0	R25.6	R6.75	9.6	12.3

REEL	Reel Size	Box	Box Size(mm)	Carton	Carton Size(mm)	G.W.(kg)
10,000 pcs	7 inch	100,000pcs	210×208×205	400,000 pcs	440×440×230	

11 Packaging Information

11.4 SOT-23-5L Tape and Reel Information

SOT-23-5L Tape and Reel Information

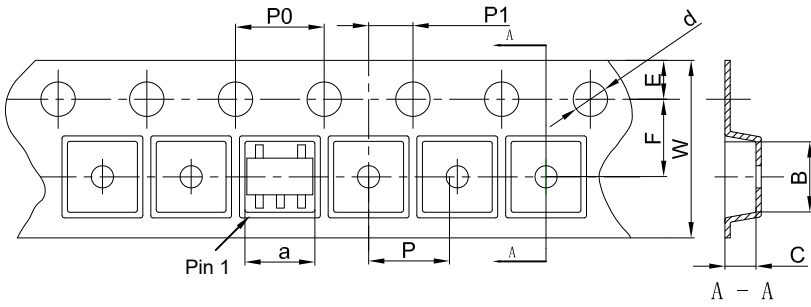

Packaging Description:

SOT-23-5L parts are shipped in tape. The carrier tape is made from a dissipative (carbon filled) polycarbonate resin. The cover tape is a multilayer film (Heat Activated Adhesive in nature) primarily composed of polyester film, adhesive layer, sealant, and anti-static sprayed agent. These reeled parts in standard option are shipped with 3,000 units per 7" or 18.0cm diameter reel. The reels are clear in color and is made of polystyrene plastic (anti-static coated).

Dimensions are in millimeter										
Pkg type	a	B	C	d	E	F	P0	P	P1	W
SOT-23-5L	3.17	3.23	1.37	Ø1.55	1.75	3.50	4.00	4.00	2.00	8.00

SOT-23-5L Tape Leader and Trailer

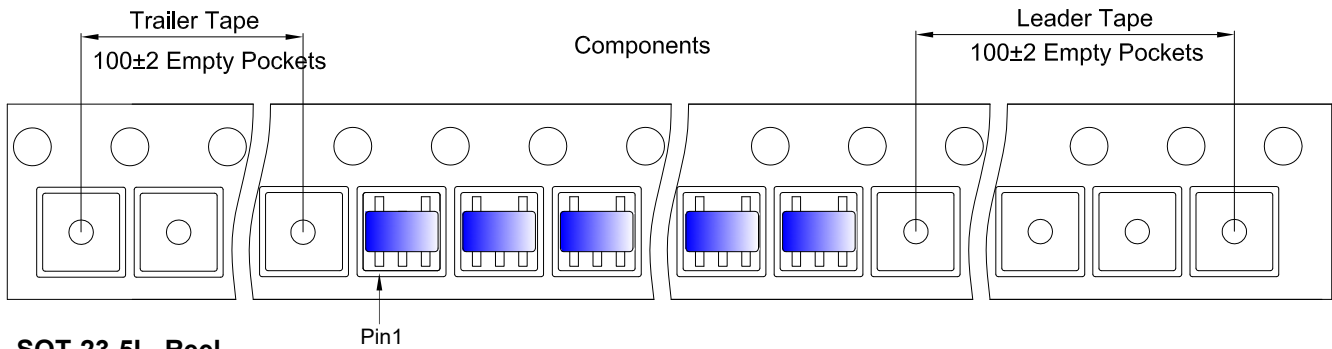

SOT-23-5L Reel

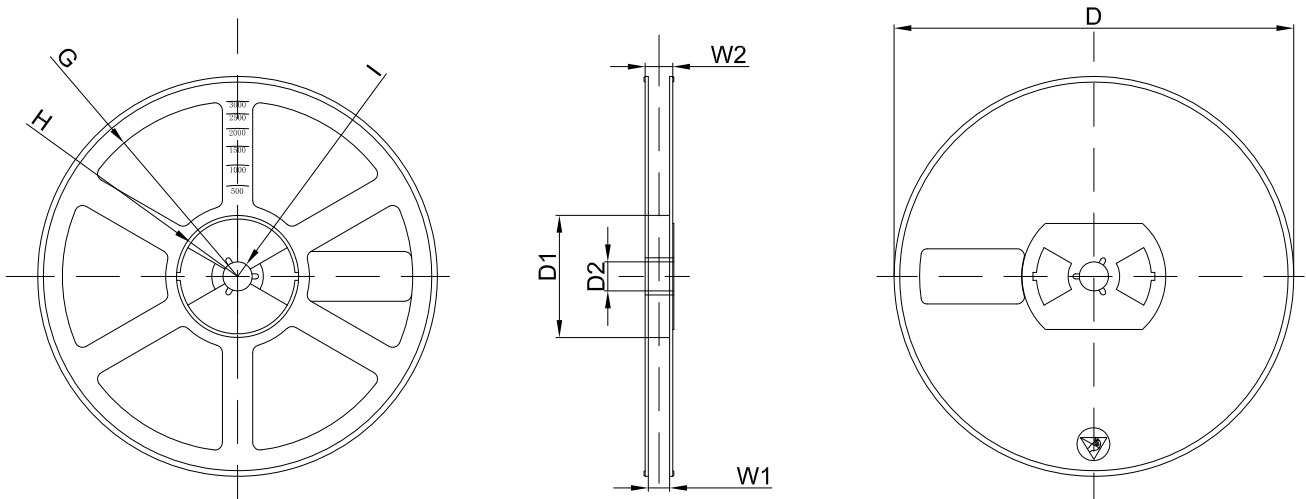

Dimensions are in millimeter								
Reel Option	D	D1	D2	G	H	I	W1	W2
7" Dia	Ø180.00	60.00	13.00	R78.00	R25.60	R6.50	9.50	13.10

REEL	Reel Size	Box	Box Size(mm)	Carton	Carton Size(mm)	G.W.(kg)
3000 pcs	7 inch	30,000 pcs	203×203×195	120,000 pcs	438×438×220	

12 Notes and Revision History

12.1 Associated Product Family and Others

To view other products of the same type or IC products of other types, click the official website of JSCJ -- <https://www.jscj-elec.com> for more details.

12.2 Notes

Electrostatic Discharge Caution



This IC may be damaged by ESD. Relevant personnel shall comply with correct installation and use specifications to avoid ESD damage to the IC. If appropriate measures are not taken to prevent ESD damage, the hazards caused by ESD include but are not limited to degradation of integrated circuit performance or complete damage of integrated circuit. For some precision integrated circuits, a very small parameter change may cause the whole device to be inconsistent with its published specifications.

Junction-to-ambient Thermal Resistance $R_{\Theta JA}$

Definition: The junction to ambient thermal resistance $R_{\Theta JA}$ is a metric of the thermal performance of the device's packages. By comparing the metric of different companies on the same product package, the thermal performance of the product can be roughly estimated in a relative sense. $R_{\Theta JA}$ is measured under the conditions specified in the corresponding specifications. If the measurement of $R_{\Theta JA}$ of two products follows different specifications and standards, or although the same specifications and standards are adopted, it is not tested in strict accordance with the specifications, then the $R_{\Theta JA}$ of two products will lose the meaning of comparison. This product follows the test specified by JEDEC in the EIA/JESD51-x series documents. $R_{\Theta JA}$ is measured in still air with $T_A = 25^\circ\text{C}$ and installed on a 1 in 2 FR-4 board covered with 2 ounces of copper.

Usage: Junction to ambient thermal resistance $R_{\Theta JA}$ is a parameter defined at the system level rather than on a single device or chip. In the test of $R_{\Theta JA}$ provided in the data sheet, most of the heat generated by the operation of the device is dissipated through the test board rather than the packaging surface of the device. In fact, the design and layout of PCB (such as chip or pad size, internal package geometry, etc.) will significantly affect $R_{\Theta JA}$. At this time, any calculation of the junction temperature or thermal power consumption of the device by applying $R_{\Theta JA}$ in the data sheet will have a very large error, so that it does not match the real performance of the device. Therefore, $R_{\Theta JA}$ should be used as the relative comparison of product packaging thermal performance between different companies, rather than directly using $R_{\Theta JA}$ in the data sheet in the actual calculation.

Reference Maximum Power Dissipation for Continuous Operation $P_{D Ref}$

The reference maximum power dissipation for continuous operation $P_{D Ref}$ is not an accurate value obtained from the actual test. It is a theoretical value obtained according to the heat dissipation capacity of packaging combined with practical application. It is used to compare the differences of heat dissipation capacity more intuitively between products of different companies. This value is only for estimation reference and cannot be used as an index of the actual performance of the device for circuit design.

12 Notes and Revision History

12.3 Revision History

December, 2022: changed from rev - 2.3 to rev - 2.4:

- Changed the data sheet layout to JSCJ format;
- Page 4 ~ 5, Pin Configuration and Marking Information, added the schematic diagram corresponding to the package;
- Page 6, Pin Configuration and Marking Information, added Pin Function section;
- Page 6, Pin Configuration and Marking Information, added Marking Information sections;
- Page 10 ~ 14, Typical Characteristics, added the CJ6101-1.8V device;
- Page 16 ~ 17, Detailed Description, added and modified the content of the text;
- Page 18 ~ 19, Application Information, added and modified the content of the text;
- Page 24, added the Packing Information section.

December, 2022: changed from rev - 2.2 to rev - 2.3:

- Page 2, Orderable Information, added new device "CJ6101A25M".

June, 2022: changed from rev - 2.1 to rev - 2.2:

- Page 2, added the ECO PLAN and MSL into Orderable Information;
- Page 3, added the description of the Orderable Information;
- Page 8 ~ 12, added the description of " $V_{OUT} = 3.3V$ " into "CJ6101 Series".

April, 2022: changed from rev - 2.0 to rev - 2.1:

- Page 2, added orderable information;
- Page 4, note (4) and (5), changed CJ to JSCJ.

March, 2022: updated CJ6101 series rev - 2.0.

DISCLAIMER

IMPORTANT NOTICE, PLEASE READ CAREFULLY

The information in this data sheet is intended to describe the operation and characteristics of our products. JSCJ has the right to make any modification, enhancement, improvement, correction or other changes to any content in this data sheet, including but not limited to specification parameters, circuit design and application information, without prior notice.

Any person who purchases or uses JSCJ products for design shall: 1. Select products suitable for circuit application and design; 2. Design, verify and test the rationality of circuit design; 3. Procedures to ensure that the design complies with relevant laws and regulations and the requirements of such laws and regulations. JSCJ makes no warranty or representation as to the accuracy or completeness of the information contained in this data sheet and assumes no responsibility for the application or use of any of the products described in this data sheet.

Without the written consent of JSCJ, this product shall not be used in occasions requiring high quality or high reliability, including but not limited to the following occasions: medical equipment, military facilities and aerospace. JSCJ shall not be responsible for casualties or property losses caused by abnormal use or application of this product.

Official Website: www.jscj-elec.com

Copyright © JIANGSU CHANGJING ELECTRONICS TECHNOLOGY CO., LTD.