



# ***FM25Q64***

# ***64M-BIT SERIAL FLASH MEMORY***

**Datasheet**

---

**Aug. 2017**

# 1. Description

The FM25Q64 is a 64M-bit (8M-byte) Serial Flash memory, with advanced write protection mechanisms. The FM25Q64 supports the standard Serial Peripheral Interface (SPI), Dual/Quad I/O as well as 2-clock instruction cycle Quad Peripheral Interface (QPI). They are ideal for code shadowing to RAM, executing code directly from Dual/Quad SPI (XIP) and storing voice, text and data.

The FM25Q64 can be programmed 1 to 256 bytes at a time, using the Page Program instruction. It is designed to allow either single Sector/Block at a time or full chip erase operation. The FM25Q64 can be configured to protect part of the memory as the software protected mode. The device can sustain a minimum of 100K program/erase cycles on each sector or block.

## 2. Features

- **64Mbit of Flash memory**
  - 2048 uniform sectors with 4K-byte each
  - 128 uniform blocks with 64K-byte each or
  - 256 uniform blocks with 32K-byte each
  - 256 bytes per programmable page
- **Wide Operation Range**
  - 2.3V~3.6V single voltage supply
  - Industrial temperature range
- **Serial Interface**
  - Standard SPI: CLK, CS#, DI, DO, WP#
  - Dual SPI: CLK, CS#, DQ<sub>0</sub>, DQ<sub>1</sub>, WP#
  - Quad SPI: CLK, CS#, DQ<sub>0</sub>, DQ<sub>1</sub>, DQ<sub>2</sub>, DQ<sub>3</sub>
  - QPI: CLK, CS#, DQ<sub>0</sub>, DQ<sub>1</sub>, DQ<sub>2</sub>, DQ<sub>3</sub>
  - Continuous READ mode support
  - Program/Erase Suspend and Resume support
  - Allow true XIP (execute in place) operation
- **High Performance**
  - Max FAST\_READ clock frequency: 104MHz
  - Max READ clock frequency: 66MHz
  - Typical page program time: 0.6ms
  - Typical sector erase time: 45ms
  - Typical block erase time: 120/150ms
  - Typical chip erase time: 20s
- **Low Power Consumption**
  - Typical Deep Power Down current: <1μA
- **Security**
  - Software and hardware write protection
  - Lockable 4X256-Byte OTP security Pages
  - 64-Bit Unique ID for each device
  - Discoverable parameters(SFDP) register

- **High Reliability**
  - Endurance: 100,000 program/erase cycles
  - Data retention: 20 years
- **Green Package**
  - 8-pin SOP (150mil)
  - 8-pin SOP (208mil)
  - 8-pad TDFN (5x6mm)
  - 24-ball BGA (8x6mm)
  - All Packages are RoHS Compliant and Halogen-free

## 3. Packaging Type

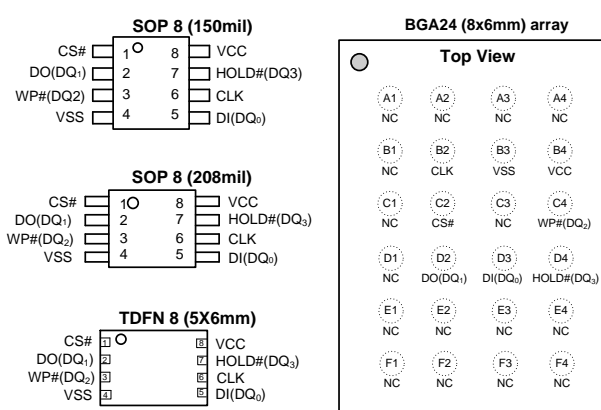

## 4. Pin Configurations

PIN NO.	PIN NAME	I/O	FUNCTION
1	CS#	I	Chip Select Input
2	DO (DQ <sub>1</sub> )	I/O	Data Output (Data Input Output 1) <sup>(1)</sup>
3	WP# (DQ <sub>2</sub> )	I/O	Write Protect Input (Data Input Output 2) <sup>(2)</sup>
4	VSS		Ground
5	DI (DQ <sub>0</sub> )	I/O	Data Input (Data Input Output 0) <sup>(1)</sup>
6	CLK	I	Serial Clock Input
7	HOLD# (DQ <sub>3</sub> )	I/O	Hold Input (Data Input Output 3) <sup>(2)</sup>
8	VCC		Power Supply

**Note:**

- 1 DQ<sub>0</sub> and DQ<sub>1</sub> are used for Dual SPI instructions.
- 2 DQ<sub>0</sub> – DQ<sub>3</sub> are used for Quad SPI and QPI instructions.

## 5. Block Diagram

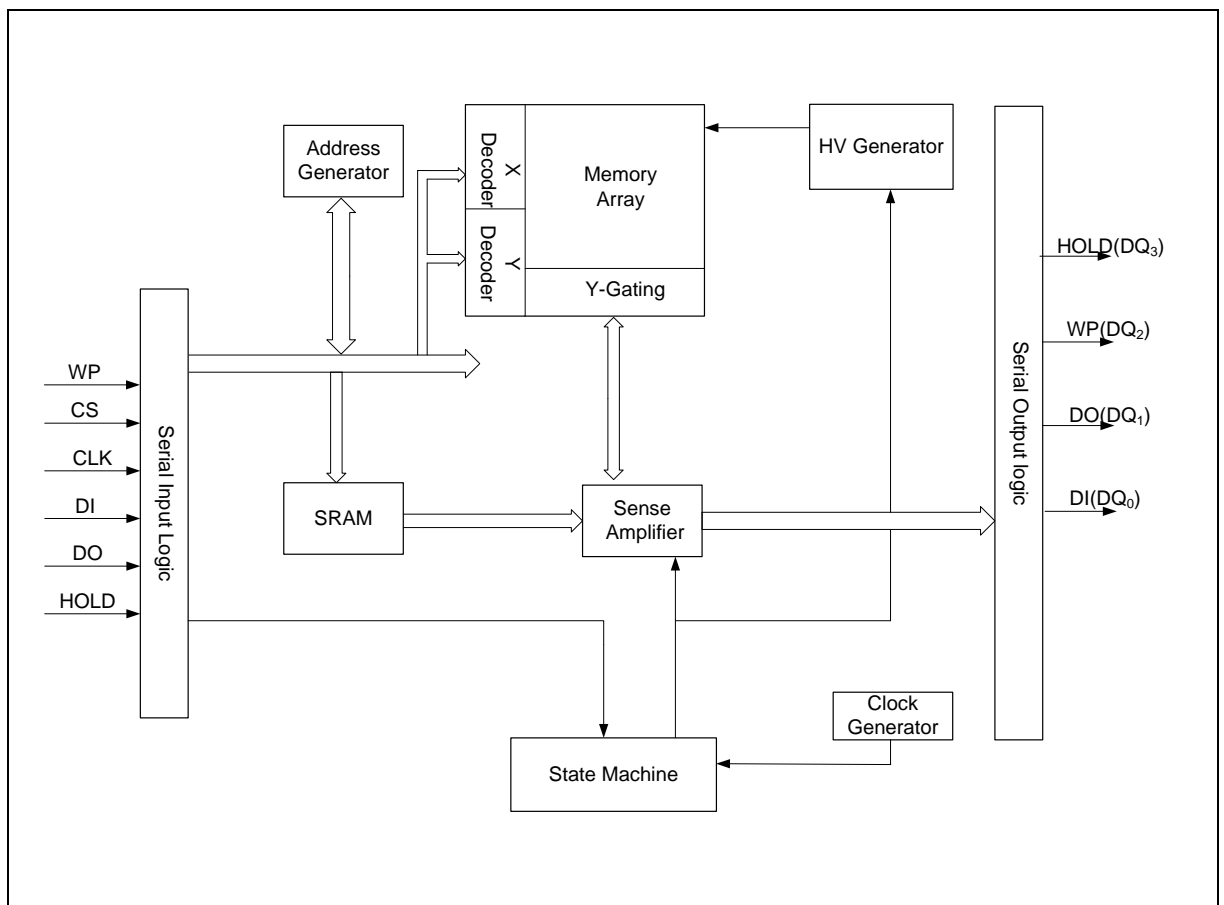

Figure 1 FM25Q64 Serial Flash Memory Block Diagram

## 6. Pin Descriptions

**Serial Clock (CLK):** The SPI Serial Clock Input (CLK) pin provides the timing for serial input and output operations.

**Serial Data Input, Output and I/Os (DI, DO and DQ<sub>0</sub>, DQ<sub>1</sub>, DQ<sub>2</sub>, DQ<sub>3</sub>):** The FM25Q64 supports standard SPI, Dual SPI, Quad SPI and QPI operation. Standard SPI instructions use the unidirectional DI (input) pin to serially write instructions, addresses or data to the device on the rising edge of the Serial Clock (CLK) input pin. Standard SPI also uses the unidirectional DO (output) to read data or status from the device on the falling edge of CLK.

Dual/Quad SPI and QPI instructions use the bidirectional DQ pins to serially write instructions, addresses or data to the device on the rising edge of CLK and read data or status from the device on the falling edge of CLK. Quad SPI and QPI instructions require the non-volatile Quad Enable bit (QE) in Status Register-2 to be set. When QE=1, the WP# pin becomes DQ<sub>2</sub> and HOLD# pin becomes DQ<sub>3</sub>.

**Chip Select (CS#):** The SPI Chip Select (CS#) pin enables and disables device operation. When CS# is high, the device is deselected and the Serial Data Output (DO, or DQ<sub>0</sub>, DQ<sub>1</sub>, DQ<sub>2</sub>, DQ<sub>3</sub>) pins are at high impedance. When deselected, the devices power consumption will be at standby levels unless an internal erase, program or write status register cycle is in progress. When CS# is brought low, the device will be selected, power consumption will increase to active levels and instructions can be written to and data read from the device. After power-up, CS# must transition from high to low before a new instruction will be accepted. The CS# input must track the VCC supply level at power-up (see “9 Write Protection” and Figure 68). If needed a pull-up resistor on CS# can be used to accomplish this.

**HOLD (HOLD#):** The HOLD# pin allows the device to be paused while it is actively selected. When HOLD# is brought low, while CS# is low, the DO pin will be at high impedance and signals on the DI and CLK pins will be ignored (don't care). When HOLD# is brought high, device operation can resume. The HOLD# function can be useful when multiple devices are sharing the same SPI signals. The HOLD# pin is active low. When the QE bit of Status Register-2 is set for Quad I/O, the HOLD# pin function is not available since this pin is used for DQ<sub>3</sub>.

**Write Protect (WP#):** The Write Protect (WP#) pin can be used to prevent the Status Registers from being written. Used in conjunction with the Status Register's Block Protect (CMP, SEC, TB, BP2, BP1 and BP0) bits and Status Register Protect (SRP) bits, a portion as small as a 4KB sector or the entire memory array can be hardware protected. The WP# pin is active low. However, when the QE bit of Status Register-2 is set for Quad I/O, the WP# pin function is not available since this pin is used for DQ<sub>2</sub>.

## 7. Memory Organization

The FM25Q64 array is organized into 32,768 programmable pages of 256-bytes each. Up to 256 bytes can be programmed (bits are programmed from 1 to 0) at a time. Pages can be erased in groups of 16 (4KB sector erase), groups of 128 (32KB block erase), groups of 256 (64KB block erase) or the entire chip (chip erase). The FM25Q64 has 2,048 erasable sectors, 256 erasable 32-k byte blocks and 128 erasable 64-k byte blocks respectively. The small 4KB sectors allow for greater flexibility in applications that require data and parameter storage.

**Table 1 Memory Organization**

Block (64KB)	Block (32KB)	Sector (4KB)	Address Range	
127	255   254	2047	7FF000h	7FFFFFFh
		...	...	...
		2032	7F0000h	7F0FFFh
126	253   252	2031	7EF000h	7EFFFFh
		...	...	...
		2016	7E0000h	7E0FFFh
125	251   250	2015	7DF000h	7DFFFFh
		...	...	...
		2000	7D0000h	7D0FFFh
...	...	...	...	...
...	...	...	...	...
2	5   4	47	02F000h	02FFFFh
		...	...	...
		32	020000h	020FFFh
1	3   2	31	01F000h	01FFFFh
		...	...	...
		16	010000h	010FFFh
0	1   0	15	00F000h	00FFFFh
		...	...	...
		2	002000h	002FFFh
		1	001000h	001FFFh
		0	000000h	000FFFh

## 8. Device Operations

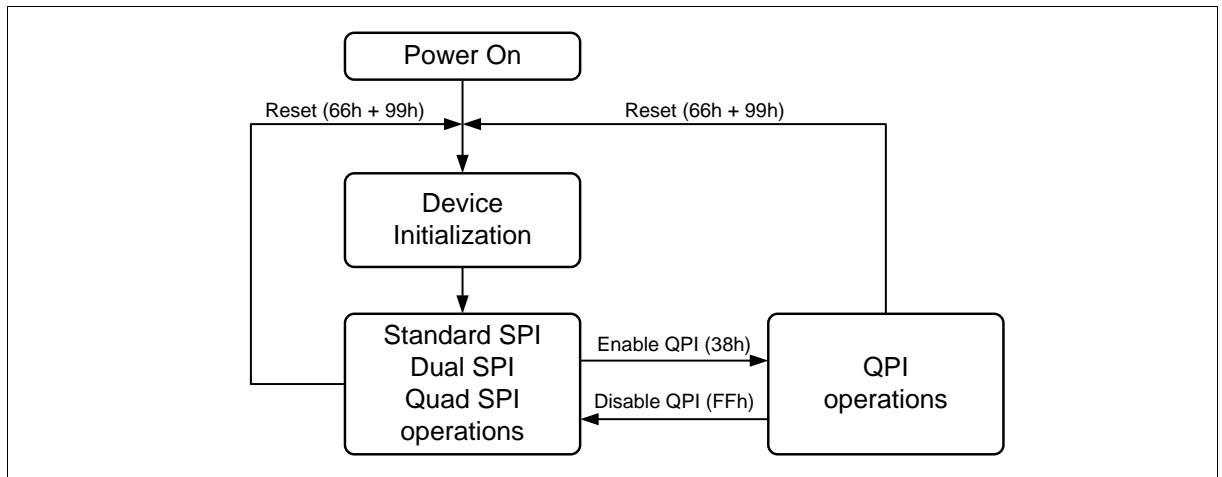

Figure 2 FM25Q64 Serial Flash Memory Operation Diagram

### 8.1. Standard SPI

The FM25Q64 is accessed through an SPI compatible bus consisting of four signals: Serial Clock (CLK), Chip Select (CS#), Serial Data Input (DI) and Serial Data Output (DO). Standard SPI instructions use the DI input pin to serially write instructions, addresses or data to the device on the rising edge of CLK. The DO output pin is used to read data or status from the device on the falling edge of CLK.

SPI bus operation Mode 0 (0,0) and 3 (1,1) are supported. The primary difference between Mode 0 and Mode 3 concerns the normal state of the CLK signal when the SPI bus master is in standby and data is not being transferred to the Serial Flash. For Mode 0, the CLK signal is normally low on the falling and rising edges of CS#. For Mode 3, the CLK signal is normally high on the falling and rising edges of CS#.

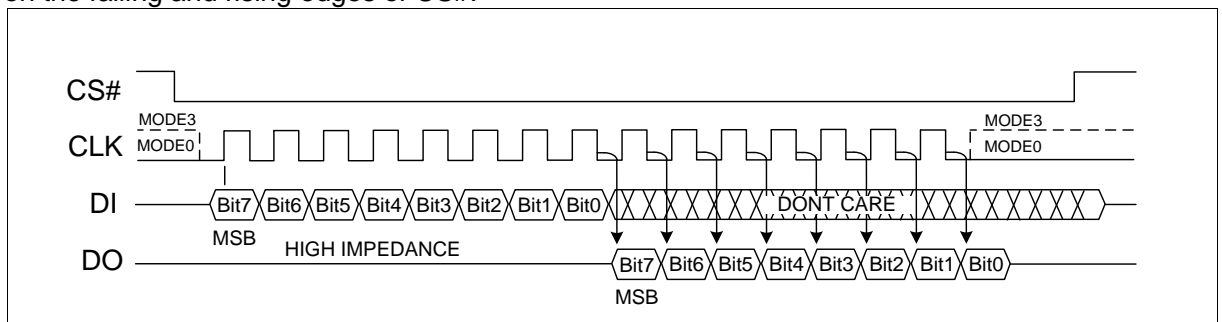

Figure 3 The difference between Mode 0 and Mode 3

### 8.2. Dual SPI

The FM25Q64 supports Dual SPI operation when using instructions such as “Fast Read Dual Output (3Bh)” and “Fast Read Dual I/O (BBh)”. These instructions allow data to be transferred to or from the device at two to three times the rate of ordinary Serial Flash devices. The Dual SPI Read instructions are ideal for quickly downloading code to RAM upon power-up (code-shadowing) or for executing non-speed-critical code directly from the SPI bus (XIP). When using Dual SPI instructions, the DI and DO pins become bidirectional I/O pins: DQ<sub>0</sub> and DQ<sub>1</sub>.

### 8.3. Quad SPI

The FM25Q64 supports Quad SPI operation when using instructions such as “Fast Read Quad Output (6Bh)”, “Fast Read Quad I/O (EBh)”, “Word Read Quad I/O (E7h)” and “Octal Word Read Quad I/O (E3h)”. These instructions allow data to be transferred to or from the device four to six times the rate of ordinary Serial Flash. The Quad Read instructions offer a significant improvement in continuous and random access transfer rates allowing fast code-shadowing to RAM or execution directly from the SPI bus (XIP). When using Quad SPI instructions the DI and DO pins become bidirectional  $DQ_0$  and  $DQ_1$  and the WP # and HOLD# pins become  $DQ_2$  and  $DQ_3$  respectively. Quad SPI instructions require the non-volatile Quad Enable bit (QE) in Status Register-2 to be set.

### 8.4. QPI

The FM25Q64 supports Quad Peripheral Interface (QPI) operations only when the device is switched from Standard/Dual/Quad SPI mode to QPI mode using the “Enable QPI (38h)” instruction. The typical SPI protocol requires that the byte-long instruction code being shifted into the device only via DI pin in eight serial clocks. The QPI mode utilizes all four DQ pins to input the instruction code, thus only two serial clocks are required. This can significantly reduce the SPI instruction overhead and improve system performance in an XIP environment. Standard/Dual/Quad SPI mode and QPI mode are exclusive. Only one mode can be active at any given time. “Enable QPI (38h)” and “Disable QPI (FFh)” instructions are used to switch between these two modes. Upon power-up or after a software reset using “Reset (99h)” instruction, the default state of the device is Standard/Dual/Quad SPI mode. To enable QPI mode, the non-volatile Quad Enable bit (QE) in Status Register-2 is required to be set. When using QPI instructions, the DI and DO pins become bidirectional  $DQ_0$  and  $DQ_1$ , and the WP# and HOLD# pins become  $DQ_2$  and  $DQ_3$  respectively. See Figure 2 for the device operation modes.

### 8.5. Hold

For Standard SPI and Dual SPI operations, the HOLD# signal allows the FM25Q64 operation to be paused while it is actively selected (when CS# is low). The HOLD# function may be useful in cases where the SPI data and clock signals are shared with other devices. For example, consider if the page buffer was only partially written when a priority interrupt requires use of the SPI bus. In this case the HOLD# function can save the state of the instruction and the data in the buffer so programming can resume where it left off once the bus is available again. The HOLD# function is only available for standard SPI and Dual SPI operation, not during Quad SPI or QPI.

To initiate a HOLD# condition, the device must be selected with CS# low. A HOLD# condition will activate on the falling edge of the HOLD# signal if the CLK signal is already low. If the CLK is not already low the HOLD# condition will activate after the next falling edge of CLK. The HOLD# condition will terminate on the rising edge of the HOLD# signal if the CLK signal is already low. If the CLK is not already low the HOLD# condition will terminate after the next falling edge of CLK. During a HOLD# condition, the Serial Data Output (DO) is high impedance, and Serial Data Input (DI) and Serial Clock (CLK) are ignored. The Chip Select (CS#) signal should be kept active (low) for the full duration of the HOLD# operation to avoid resetting the internal logic state of the device.

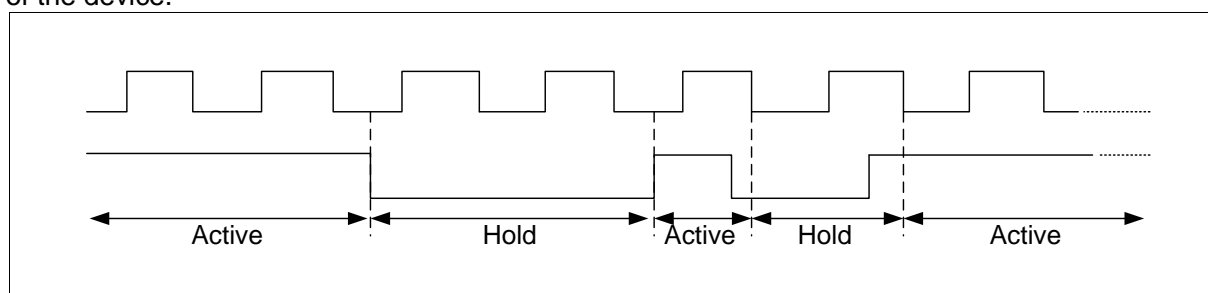

Figure 4 Hold Condition Waveform

## 9. Write Protection

Applications that use non-volatile memory must take into consideration the possibility of noise and other adverse system conditions that may compromise data integrity. To address this concern, the FM25Q64 provides several means to protect the data from inadvertent writes.

### Write Protect Features

- Device resets when VCC is below threshold
- Time delay write disable after Power-up
- Write enable/disable instructions and automatic write disable after erase or program
- Software and Hardware (WP# pin) write protection using Status Register
- Write Protection using Power-down instruction
- Lock Down write protection for Status Register until the next power-up
- One Time Program (OTP) write protection for array and Security Sectors using Status Register.

Upon power-up or at power-down, the FM25Q64 will maintain a reset condition while VCC is below the threshold value of VWI, (See “12.3 Power-up Timing” and Figure 68). While reset, all operations are disabled and no instructions are recognized. During power-up and after the VCC voltage exceeds VWI, all program and erase related instructions are further disabled for a time delay of  $t_{PUW}$ . This includes the Write Enable, Page Program, Sector Erase, Block Erase, Chip Erase and the Write Status Register instructions. Note that the chip select pin (CS#) must track the VCC supply level at power-up until the VCC-min level and  $t_{VSL}$  time delay is reached. If needed a pull-up resistor on CS# can be used to accomplish this.

After power-up the device is automatically placed in a write-disabled state with the Status Register Write Enable Latch (WEL) set to a 0. A Write Enable instruction must be issued before a Page Program, Sector Erase, Block Erase, Chip Erase or Write Status Register instruction will be accepted. After completing a program, erase or write instruction the Write Enable Latch (WEL) is automatically cleared to a write-disabled state of 0.

Software controlled write protection is facilitated using the Write Status Register instruction and setting the Status Register Protect (SRP0, SRP1) and Block Protect (CMP, SEC, TB, BP2, BP1 and BP0) bits. These settings allow a portion as small as a 4KB sector or the entire memory array to be configured as read only. Used in conjunction with the Write Protect (WP#) pin, changes to the Status Register can be enabled or disabled under hardware control. See Status Register section for further information. Additionally, the Power-down instruction offers an extra level of write protection as all instructions are ignored except for the Release Power-down instruction.

## 10. Status Register

The Read Status Register instructions can be used to provide status on the availability of the Flash memory array, if the device is write enabled or disabled, the state of write protection, Quad SPI setting, Security Sector lock status. The Write Status Register instruction can be used to configure the device write protection features, Quad SPI setting and Security Sector OTP lock. Write access to the Status Register is controlled by the state of the non-volatile Status Register Protect bits (SRP0, SRP1), the Write Enable instruction, and during Standard/Dual SPI operations, the WP# pin.

Factory default for all Status Register bits are 0.

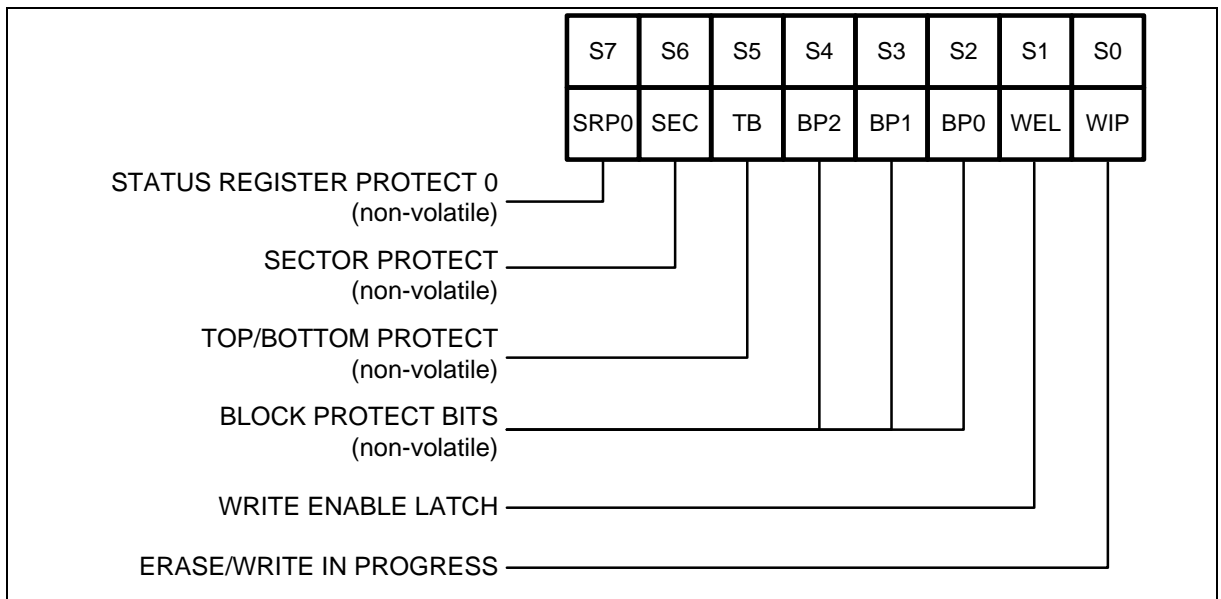

Figure 5 Status Register-1

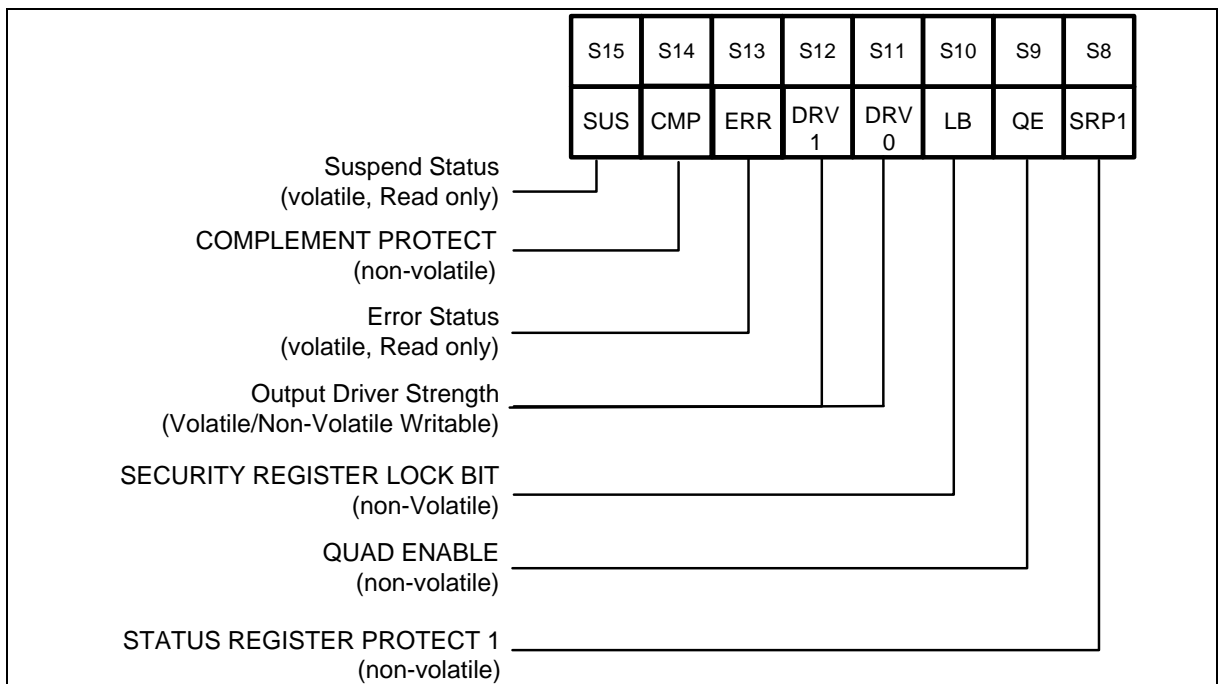

Figure 6 Status Register-2

## 10.1. WIP Bit

WIP is a read only bit in the status register (S0) that is set to a 1 state when the device is executing a Page Program, Quad Page Program, Sector Erase, Block Erase, Chip Erase, Write Status Register or Erase/Program Security Sector instruction. During this time the device will ignore further instructions except for the Read Status Register instruction (see  $t_W$ ,  $t_{PP}$ ,  $t_{SE}$ ,  $t_{BE}$ , and  $t_{CE}$  in “12.6 AC Electrical Characteristics”). When the program, erase or write status register (or security sector) instruction has completed, the WIP bit will be cleared to a 0 state indicating the device is ready for further instructions.

## 10.2. Write Enable Latch (WEL)

Write Enable Latch (WEL) is a read only bit in the status register (S1) that is set to 1 after executing a Write Enable Instruction. The WEL status bit is cleared to 0 when the device is write disabled. A write disable state occurs upon power-up or after any of the following instructions: Write Disable, Page Program, Quad Page Program, Sector Erase, Block Erase, Chip Erase, Write Status Register, Erase Security Sector and Program Security Sector.

## 10.3. Block Protect Bits (BP2, BP1, BP0)

The Block Protect Bits (BP2, BP1, BP0) are non-volatile read/write bits in the status register (S4, S3, and S2) that provide Write Protection control and status. Block Protect bits can be set using the Write Status Register Instruction (see  $t_W$  in “12.6 AC Electrical Characteristics”). All, none or a portion of the memory array can be protected from Program and Erase instructions (see Table 3 Status Register Memory Protection). The factory default setting for the Block Protection Bits is 0, none of the array protected.

## 10.4. Top/Bottom Block Protect (TB)

The non-volatile Top/Bottom bit (TB) controls if the Block Protect Bits (BP2, BP1, BP0) protect from the Top (TB=0) or the Bottom (TB=1) of the array as shown in Table 3 Status Register Memory Protection table. The factory default setting is TB=0. The TB bit can be set with the Write Status Register Instruction depending on the state of the SRP0, SRP1 and WEL bits.

## 10.5. Sector/Block Protect (SEC)

The non-volatile Sector/Block Protect bit (SEC) controls if the Block Protect Bits (BP2, BP1, BP0) protect either 4KB Sectors (SEC=1) or 64KB Blocks (SEC=0) in the Top (TB=0) or the Bottom (TB=1) of the array as shown in Table 3 Status Register Memory Protection table. The default setting is SEC=0.

## 10.6. Complement Protect (CMP)

The Complement Protect bit (CMP) is a non-volatile read/write bit in the status register (S12). It is used in conjunction with SEC, TB, BP2, BP1 and BP0 bits to provide more flexibility for the array protection. Once CMP is set to 1, previous array protection set by SEC, TB, BP2, BP1 and BP0 will be reversed. For instance, when CMP=0, a top 4KB sector can be protected while the rest of the array is not; when CMP=1, the top 4KB sector will become unprotected while the rest of the array become read-only. Please refer to Table 3 Status Register Memory Protection table for details. The default setting is CMP=0.

## 10.7. Status Register Protect (SRP1, SRP0)

The Status Register Protect bits (SRP1 and SRP0) are non-volatile read/write bits in the status register (S8 and S7). The SRP bits control the method of write protection: software protection, hardware protection, power supply lock-down or one time programmable (OTP) protection.

**Table 2 Status Register Protect bits**

SRP1	SRP0	WP#	Status Register	Description
0	0	X	Software Protection	WP# pin has no control. The Status register can be written to after a Write Enable instruction, WEL=1. (Factory Default)
0	1	0	Hardware Protected	When WP# pin is low the Status Register locked and can not be written to.
0	1	1	Hardware Unprotected	When WP# pin is high the Status register is unlocked and can be written to after a Write Enable instruction, WEL=1.
1	0	X	Power Supply Lock-Down	Status Register is protected and can not be written to again until the next power-down, power-up cycle. <sup>(1)</sup>
1	1	X	One Time Program	Status Register is permanently protected and can not be written to.

**Note:**

1. When SRP1, SRP0 = (1, 0), a power-down, power-up cycle will change SRP1, SRP0 to (0, 0) state.

## 10.8. Output driver strength (DRV1, DRV0)

The DRV1 & DRV0 bits are used to determine the output driver strength.

DRV1, DRV0	Driver Strength
0,0	100%
0,1	75%
1,0	50%
1,1	25%

## 10.9. Erase/Program Suspend Status (SUS)

The Suspend Status bit is a read only bit in the status register (S11) that is set to 1 after executing a Erase/Program Suspend (75h) instruction. The SUS status bit is cleared to 0 by Erase/Program Resume (7Ah) instruction as well as a power-down, power-up cycle.

## 10.10. Error Bit (ERR)

The Error bit is a status flag, which shows the status of last Program/Erase operation. It will be set to "1", if the Program/Erase operation fails. If the Program/Erase region is protected, Error bit will not be set to "1".

## 10.11. Security Sector Lock Bit (LB)

The Security Register Lock Bit (LB) is non-volatile One Time Program (OTP) bit in Status Register (S10) that provides the write protect control and status to the Security Registers. The default state of LB is 0, Security Registers are unlocked. LB can be set to 1 using the Write Status Register instruction. LB bit is One Time Programmable (OTP), once it's set to 1, the



Security Registers will become read-only permanently.

## 10.12. Quad Enable (QE)

The Quad Enable (QE) bit is a non-volatile read/write bit in the status register (S9) that allows Quad SPI and QPI operation. When the QE bit is set to a 0 state (factory default), the WP# pin and HOLD# are enabled. When the QE bit is set to a 1, the Quad DQ<sub>2</sub> and DQ<sub>3</sub> pins are enabled, and WP# and HOLD# functions are disabled.

QE bit is required to be set to a 1 before issuing an “Enable QPI (38h)” to switch the device from Standard/Dual/Quad SPI to QPI, otherwise the command will be ignored. When the device is in QPI mode, QE bit will remain to be 1. A “Write Status Register” command in QPI mode cannot change QE bit from a “1” to a “0”.

**WARNING:** If the WP# or HOLD# pins are tied directly to the power supply or ground during standard SPI or Dual SPI operation, the QE bit should never be set to a 1.

## 10.13. Status Register Memory Protection

Table 3 Status Register Memory Protection

STATUS REGISTER						FM25Q64 (64M-BIT) MEMORY PROTECTION			
CMP	SEC	TB	BP2	BP1	BP0	PROTECTED BLOCK(S)	PROTECTED ADDRESSES	PROTECTED DENSITY	PROTECTED PORTION
0	X	X	0	0	0	NONE	NONE	NONE	NONE
0	0	0	0	0	1	126 and 127	7E0000h – 7FFFFFFh	128KB	Upper 1/64
0	0	0	0	1	0	124 thru 127	7C0000h – 7FFFFFFh	256KB	Upper 1/32
0	0	0	0	1	1	120 thru 127	780000h – 7FFFFFFh	512KB	Upper 1/16
0	0	0	1	0	0	112 thru 127	700000h – 7FFFFFFh	1MB	Upper 1/8
0	0	0	1	0	1	96 thru 127	600000h – 7FFFFFFh	2MB	Upper 1/4
0	0	0	1	1	0	64 thru 127	400000h – 7FFFFFFh	4MB	Upper 1/1
0	0	1	0	0	1	0 and 1	000000h – 01FFFFh	128KB	Lower 1/64
0	0	1	0	1	0	0 thru 3	000000h – 03FFFFh	256KB	Lower 1/32
0	0	1	0	1	1	0 thru 7	000000h – 07FFFFh	512KB	Lower 1/16
0	0	1	1	0	0	0 thru 15	000000h – 0FFFFFFh	1MB	Lower 1/8
0	0	1	1	0	1	0 thru 31	000000h – 1FFFFFFh	2MB	Lower 1/4
0	0	1	1	1	0	0 thru 63	000000h – 3FFFFFFh	4MB	Lower 1/2
0	X	X	1	1	1	0 thru 127	000000h – 7FFFFFFh	8MB	ALL
0	1	0	0	0	1	127	7FF000h – 7FFFFFFh	4KB	U - 1/2048
0	1	0	0	1	0	127	7FE000h – 7FFFFFFh	8KB	U - 1/1024
0	1	0	0	1	1	127	7FC000h – 7FFFFFFh	16KB	U - 1/512
0	1	0	1	0	X	127	7F8000h – 7FFFFFFh	32KB	U - 1/256
0	1	0	1	1	0	127	7F8000h – 7FFFFFFh	32KB	U - 1/256
0	1	1	0	0	1	0	000000h – 000FFFh	4KB	L - 1/2048
0	1	1	0	1	0	0	000000h – 001FFFh	8KB	L - 1/1024
0	1	1	0	1	1	0	000000h – 003FFFh	16KB	L - 1/512
0	1	1	1	0	X	0	000000h –	32KB	L - 1/256



STATUS REGISTER						FM25Q64 (64M-BIT) MEMORY PROTECTION			
CMP	SEC	TB	BP2	BP1	BP0	PROTECTED BLOCK(S)	PROTECTED ADDRESSES	PROTECTED DENSITY	PROTECTED PORTION
							007FFFh		
0	1	1	1	1	0	0	000000h – 007FFFh	32KB	L - 1/256
1	X	X	0	0	0	ALL	000000h – 7FFFFFFh	ALL	ALL
1	0	0	0	0	1	0 thru 125	000000h – 7DFFFFh	8,064KB	Lower 63/64
1	0	0	0	1	0	0 and 123	000000h – 7BFFFFh	7,936KB	Lower 31/32
1	0	0	0	1	1	0 thru 119	000000h – 77FFFFh	7,680KB	Lower 15/16
1	0	0	1	0	0	0 thru 111	000000h – 6FFFFFFh	7MB	Lower 7/8
1	0	0	1	0	1	0 thru 95	000000h – 5FFFFFFh	6MB	Lower 3/4
1	0	0	1	1	0	0 thru 63	000000h – 3FFFFFFh	4MB	Lower 1/2
1	0	1	0	0	1	2 thru 127	020000h – 7FFFFFFh	8,064KB	Upper 63/64
1	0	1	0	1	0	4 thru 127	040000h – 7FFFFFFh	7,936KB	Upper 31/32
1	0	1	0	1	1	8 thru 127	080000h – 7FFFFFFh	7,680KB	Upper 15/16
1	0	1	1	0	0	16 thru 127	100000h – 7FFFFFFh	7MB	Upper 7/8
1	0	1	1	0	1	32 thru 127	200000h – 7FFFFFFh	6MB	Upper 3/4
1	0	1	1	1	0	64 thru 127	400000h – 7FFFFFFh	4MB	Upper 1/2
1	X	X	1	1	1	NONE	NONE	NONE	NONE
1	1	0	0	0	1	0 thru 127	000000h – 7FEFFFh	8,188KB	L - 2047/2048
1	1	0	0	1	0	0 thru 127	000000h – 7FDFFFh	8,184KB	L - 1023/1024
1	1	0	0	1	1	0 thru 127	000000h – 7FBFFFh	8,176KB	L - 511/512
1	1	0	1	0	X	0 thru 127	000000h – 7F7FFFh	8,160KB	L - 255/256
1	1	0	1	1	0	0 thru 127	000000h – 7F7FFFh	8,160KB	L - 255/256
1	1	1	0	0	1	0 thru 127	001000h – 7FFFFFFh	8,188KB	U - 2047/2048
1	1	1	0	1	0	0 thru 127	002000h – 7FFFFFFh	8,184KB	U - 1023/1024
1	1	1	0	1	1	0 thru 127	004000h – 7FFFFFFh	8,176KB	U - 511/512
1	1	1	1	0	X	0 thru 127	008000h – 7FFFFFFh	8,160KB	U - 255/256
1	1	1	1	1	0	0 thru 127	008000h – 7FFFFFFh	8,160KB	U - 255/256

# 11. Instructions

The Standard/Dual/Quad SPI instruction set of the FM25Q64 consists of 34 basic instructions that are fully controlled through the SPI bus (see Table 45~Table 67 Instruction Set). Instructions are initiated with the falling edge of Chip Select (CS#). The first byte of data clocked into the DI input provides the instruction code. Data on the DI input is sampled on the rising edge of clock with most significant bit (MSB) first.

The QPI instruction set of the FM25Q64 consists of 23 basic instructions that are fully controlled through the SPI bus (see Table 78 Instruction Set). Instructions are initiated with the falling edge of Chip Select (CS#). The first byte of data clocked through DQ[3:0] pins provides the instruction code. Data on all four DQ pins are sampled on the rising edge of clock with most significant bit (MSB) first. All QPI instructions, addresses, data and dummy bytes are using all four DQ pins to transfer every byte of data with every two serial clocks (CLK).

Instructions vary in length from a single byte to several bytes and may be followed by address bytes, data bytes, dummy bytes (don't care), and in some cases, a combination. Instructions are completed with the rising edge of edge CS#. Clock relative timing diagrams for each instruction are included in Figure 7 through Figure 72. All read instructions can be completed after any clocked bit. However, all instructions that Write, Program or Erase must complete on a byte boundary (CS# driven high after a full 8-bits have been clocked) otherwise the instruction will be ignored. This feature further protects the device from inadvertent writes. Additionally, while the memory is being programmed or erased, or when the Status Register is being written, all instructions except for Read Status Register will be ignored until the program or erase cycle has completed.

## 11.1. Manufacturer and Device Identification

Table 4 Manufacturer and Device Identification

OP Code	MF7-MF0	ID15-ID0	ID7-ID0
ABh			16h
90h, 92h, 94h	A1h		16h
9Fh	A1h	4017h	

## 11.2. Standard SPI Instructions Set

Table 4 Standard SPI Instructions Set <sup>(1)</sup>

INSTRUCTION NAME	BYTE 1	BYTE 2	BYTE 3	BYTE 4	BYTE 5	BYTE 6
CLOCK NUMBER	(0-7)	(8-15)	(16-23)	(24-31)	(32-39)	(40-47)
Write Enable	<b>06h</b>					
Volatile SR Write Enable	<b>50h</b>					
Write Disable	<b>04h</b>					
Read Status Register-1	<b>05h</b>	(S7-S0) <sup>(2)</sup>				
Write Status Register-1	<b>01h</b>	S7-S0				
Read Status Register-2	<b>35h</b>	(S15-S8) <sup>(2)</sup>	01h can be used to program Status Register-1&2			
Write Status Register-2	<b>31h</b>	S15-S8				
Page Program	<b>02h</b>	A23-A16	A15-A8	A7-A0	D7-D0	D7-D0 <sup>(3)</sup>
Sector Erase (4KB)	<b>20h</b>	A23-A16	A15-A8	A7-A0		
Block Erase (32KB)	<b>52h</b>	A23-A16	A15-A8	A7-A0		
Block Erase (64KB)	<b>D8h</b>	A23-A16	A15-A8	A7-A0		
Chip Erase	<b>C7h/60h</b>					
Power-down	<b>B9h</b>					
Read Data	<b>03h</b>	A23-A16	A15-A8	A7-A0	(D7-D0)	
Fast Read	<b>0Bh</b>	A23-A16	A15-A8	A7-A0	dummy	(D7-D0)
Release Powerdown / ID <sup>(4)</sup>	<b>ABh</b>	dummy	dummy	dummy	(ID7-ID0) <sup>(2)</sup>	
Manufacturer/Device ID <sup>(4)</sup>	<b>90h</b>	dummy	dummy	00h	(MF7-MF0)	(ID7-ID0)
JEDEC ID <sup>(4)</sup>	<b>9Fh</b>	(MF7-MF0) Manufacturer	(ID15-ID8) Memory Type	(ID7-ID0) Capacity		
Read SFDP Register	<b>5Ah</b>	00h	00h	A7-A0	dummy	(D7-D0)
Read Unique ID <sup>(5)</sup>	<b>4Bh</b>	dummy	dummy	dummy	dummy	(UID63-UID0)
Erase Security Sectors <sup>(6)</sup>	<b>44h</b>	A23-A16	A15-A8	A7-A0		
Program Security Sectors <sup>(6)</sup>	<b>42h</b>	A23-A16	A15-A8	A7-A0	D7-D0	D7-D0 <sup>(3)</sup>
Read Security Sectors <sup>(6)</sup>	<b>48h</b>	A23-A16	A15-A8	A7-A0	dummy	(D7-D0)
Program/Erase Suspend	<b>75h</b>					
Program/Erase Resume	<b>7Ah</b>					
Enable QPI	<b>38h</b>					
Enable Reset	<b>66h</b>					
Reset	<b>99h</b>					

## 11.3. Dual SPI Instructions Set

Table 5 Dual SPI Instructions Set

INSTRUCTION NAME	BYTE 1	BYTE 2	BYTE 3	BYTE 4	BYTE 5	BYTE 6
CLOCK NUMBER	(0-7)	(8-15)	(16-23)	(24-31)	(32-39)	(40-47)
Fast Read Dual Output	3Bh	A23-A16	A15-A8	A7-A0	dummy	(D7-D0, ...) <sup>(8)</sup>
Fast Read Dual I/O	BBh	A23-A8 <sup>(7)</sup>	A7-A0, M7-M0 <sup>(7)</sup>	(D7-D0, ...) <sup>(8)</sup>		
Manufacturer/Device ID by Dual I/O <sup>(4)</sup>	92h	A23-A8 <sup>(7)</sup>	A7-A0, M7-M0 <sup>(7)</sup>	(MF7-MF0, ID7-ID0)		

## 11.4. Quad SPI Instructions Set

Table 6 Quad SPI Instructions Set

INSTRUCTION NAME	BYTE 1	BYTE 2	BYTE 3	BYTE 4	BYTE 5	BYTE 6
CLOCK NUMBER	(0-7)	(8-15)	(16-23)	(24-31)	(32-39)	(40-47)
Quad Page Program	32h	A23-A16	A15-A8	A7-A0	D7-D0, ... <sup>(10)</sup>	D7-D0, ... <sup>(3)</sup>
Fast Read Quad Output	6Bh	A23-A16	A15-A8	A7-A0	dummy	(D7-D0, ...) <sup>(10)</sup>
Fast Read Quad I/O	EBh	A23-A0, M7-M0 <sup>(9)</sup>	(xxxx, D7-D0) <sup>(11)</sup>	(D7-D0, ...) <sup>(10)</sup>		
Word Read Quad I/O <sup>(13)</sup>	E7h	A23-A0, M7-M0 <sup>(9)</sup>	(xx, D7-D0) <sup>(12)</sup>	(D7-D0, ...) <sup>(10)</sup>		
Octal Word Read Quad I/O <sup>(14)</sup>	E3h	A23-A0, M7-M0 <sup>(9)</sup>	(D7-D0, ...) <sup>(10)</sup>			
Set Burst with Wrap	77h	xxxxxx, W6-W4 <sup>(9)</sup>				
Manufacture/Device ID by Quad I/O <sup>(4)</sup>	94h	A23-A0, M7-M0 <sup>(9)</sup>	xxxx, (MF7-MF0, ID7-ID0)	(MF7-MF0, ID7-ID0, ...)		

## 11.5. QPI Instructions Set

Table 7 QPI Instructions Set<sup>(15)</sup>

INSTRUCTION NAME	BYTE 1	BYTE 2	BYTE 3	BYTE 4	BYTE 5	BYTE 6
CLOCK NUMBER	(0,1)	(2,3)	(4,5)	(6,7)	(8,9)	(10,11)
Write Enable	06h					
Volatile SR Write Enable	50h					
Write Disable	04h					
Read Status Register-1	05h	(S7-S0) <sup>(2)</sup>				
Write Status Register-1	01h	S7-S0	01h can be used to program Status Register-1&2			
Read Status Register-2	35h	(S15-S8) <sup>(2)</sup>				
Write Status Register-2	31h	S18-S8				
Page Program	02h	A23-A16	A15-A8	A7-A0	D7-D0 <sup>(10)</sup>	D7-D0 <sup>(3)</sup>



11. Fast Read Quad I/O data output format:  
 $DQ_0 = (x, x, x, x, D4, D0, D4, D0)$   
 $DQ_1 = (x, x, x, x, D5, D1, D5, D1)$   
 $DQ_2 = (x, x, x, x, D6, D2, D6, D2)$   
 $DQ_3 = (x, x, x, x, D7, D3, D7, D3)$
12. Word Read Quad I/O data output format:  
 $DQ_0 = (x, x, D4, D0, D4, D0, D4, D0)$   
 $DQ_1 = (x, x, D5, D1, D5, D1, D5, D1)$   
 $DQ_2 = (x, x, D6, D2, D6, D2, D6, D2)$   
 $DQ_3 = (x, x, D7, D3, D7, D3, D7, D3)$
13. For Word Read Quad I/O, the lowest address bit must be 0. ( $A_0 = 0$ )
14. For Octal Word Read Quad I/O, the lowest four address bits must be 0. ( $A_3, A_2, A_1, A_0 = 0$ )
15. QPI Command Address, Data input/output format:
- | CLK#   | 0  | 1  | 2   | 3   | 4   | 5   | 6  | 7  | 8  | 9  | 10 | 11 |
|--------|----|----|-----|-----|-----|-----|----|----|----|----|----|----|
| $DQ_0$ | C4 | C0 | A20 | A16 | A12 | A8  | A4 | A0 | D4 | D0 | D4 | D0 |
| $DQ_1$ | C5 | C1 | A21 | A17 | A13 | A9  | A5 | A1 | D5 | D1 | D5 | D1 |
| $DQ_2$ | C6 | C2 | A22 | A18 | A14 | A10 | A6 | A2 | D6 | D2 | D6 | D2 |
| $DQ_3$ | C7 | C3 | A23 | A19 | A15 | A11 | A7 | A3 | D7 | D3 | D7 | D3 |
16. The number of dummy clocks for QPI Fast Read, QPI Fast Read Quad I/O & QPI Burst Read with Wrap is controlled by read parameter P7 ~ P4.
17. The wrap around length for QPI Burst Read with Wrap is controlled by read parameter P3 ~ P0.

## 11.6. Write Enable (WREN) (06h)

The Write Enable (WREN) instruction (Figure 7) sets the Write Enable Latch (WEL) bit in the Status Register to a 1. The WEL bit must be set prior to every Page Program, Quad Page Program, Sector Erase, Block Erase, Chip Erase, Write Status Register and Erase/Program Security Sectors instruction. The Write Enable (WREN) instruction is entered by driving CS# low, shifting the instruction code “06h” into the Data Input (DI) pin on the rising edge of CLK, and then driving CS# high.

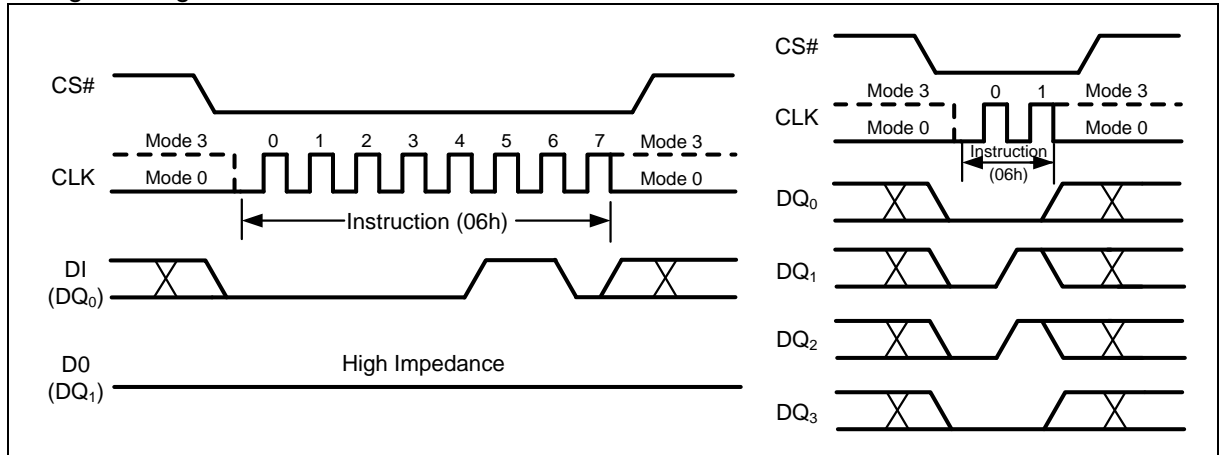

Figure 7 Write Enable Instruction for SPI Mode (left) or QPI Mode (right)

## 11.7. Write Enable for Volatile Status Register (50h)

The non-volatile Status Register bits described in section 10.1 can also be written to as volatile bits. This gives more flexibility to change the system configuration and memory protection schemes quickly without waiting for the typical non-volatile bit write cycles or affecting the endurance of the Status Register non-volatile bits. To write the volatile values into the Status Register bits, the Write Enable for Volatile Status Register (50h) instruction must be issued prior to a Write Status Register (01h/31h) instruction. Write Enable for Volatile Status Register instruction (Figure 8) will not set the Write Enable Latch (WEL) bit, it is only valid for the Write Status Register instruction to change the volatile Status Register bit values.

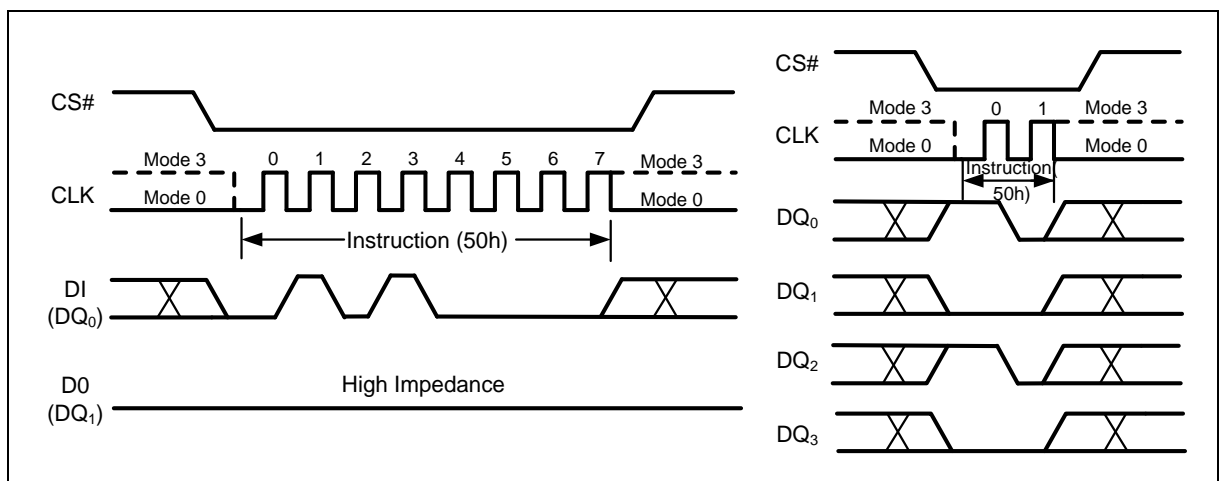

Figure 8 Write Enable for Volatile Status Register Instruction for SPI Mode (left) or QPI Mode (right)

## 11.8. Write Disable (WRDI) (04h)

The Write Disable (WRDI) instruction (Figure 9) resets the Write Enable Latch (WEL) bit in the Status Register to a 0. The Write Disable (WRDI) instruction is entered by driving CS# low, shifting the instruction code “04h” into the DI pin and then driving CS# high. Note that the WEL bit is automatically reset after Power-up and upon completion of the Write Status Register, Erase/Program Security Sectors, Page Program, Quad Page Program, Sector Erase, Block Erase, Chip Erase and Reset instructions.

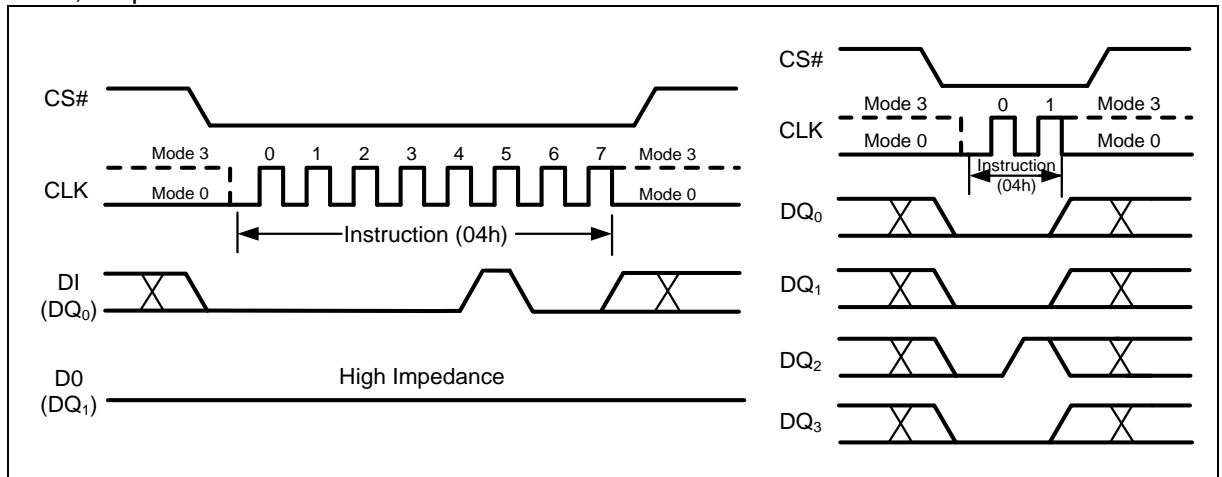

Figure 9 Write Disable Instruction for SPI Mode (left) or QPI Mode (right)

## 11.9. Read Status Register-1 (RDSR1) (05h) , Status Register-2 (RDSR2) (35h)

The Read Status Register instructions allow the 8-bit Status Registers to be read. The instruction is entered by driving CS# low and shifting the instruction code “05h” for Status Register-1 or “35h” for Status Register-2 into the DI pin on the rising edge of CLK. The status register bits are then shifted out on the DO pin at the falling edge of CLK with most significant bit (MSB) first as shown in Figure 10 and Figure 11. The Status Register bits are shown in Figure 5 and Figure 6.

The Read Status Register instruction may be used at any time, even while a Program, Erase or Write Status Register cycle is in progress. This allows the WIP status bit to be checked to determine when the cycle is complete and if the device can accept another instruction. The Status Register can be read continuously, as shown in Figure 10 and Figure 11. The instruction is completed by driving CS# high.

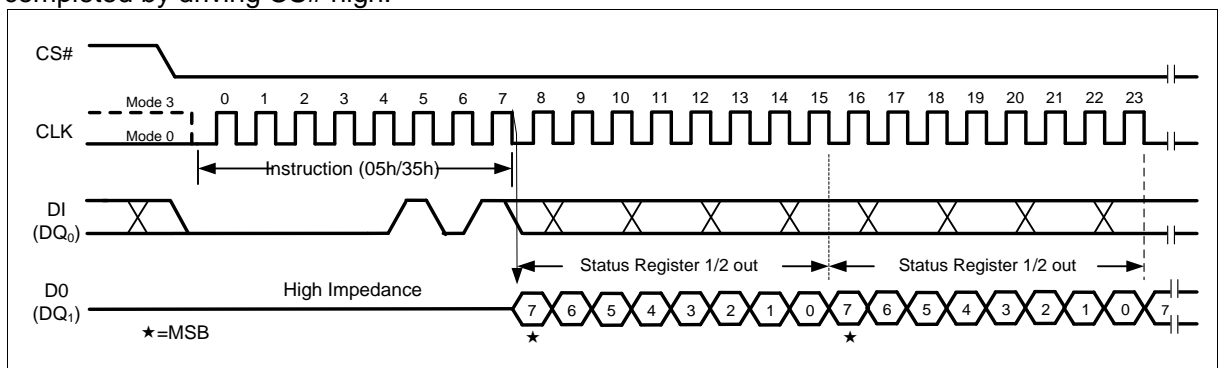

Figure 10 Read Status Register Instruction (SPI Mode)

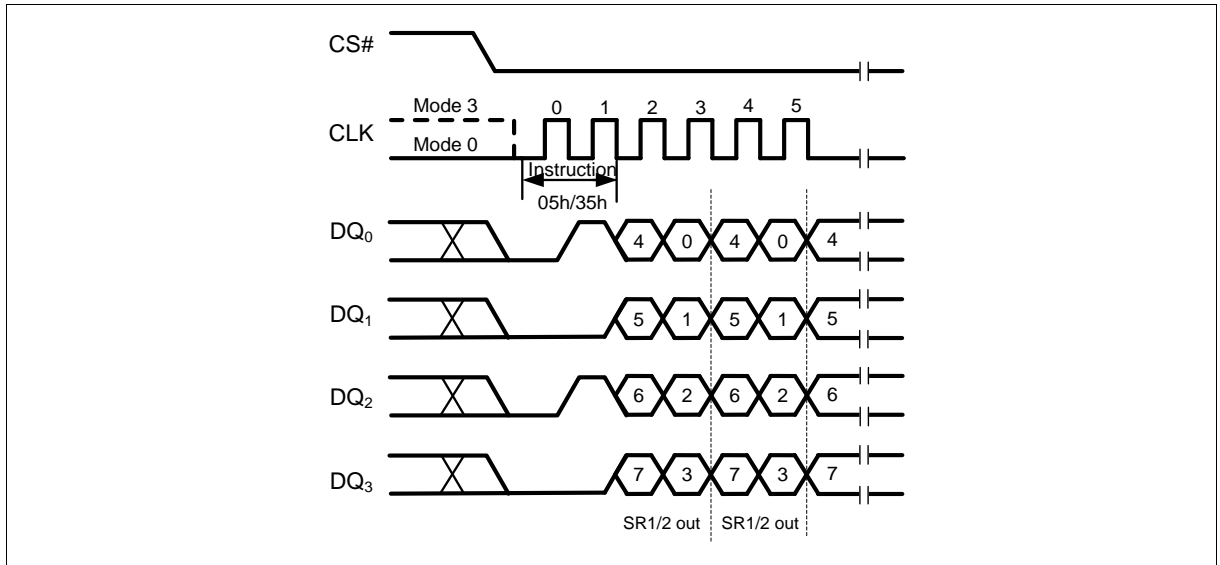

Figure 11 Read Status Register Instruction (QPI Mode)

## 11.10. Write Status Register-1(WRSR) (01h), Status Register-2 (31h)

The Write Status Register (WRSR) instruction allows the Status Register to be written. Only non-volatile Status Register bits SRP0, SEC, TB, BP2, BP1, BP0 (bits 7 thru 2 of Status Register-1), CMP, DRV0, DRV1, LB, QE, SRP1 (bits 14 and bit 12 thru 8 of Status Register-2), can be written to. All other Status Register bit locations are read-only and will not be affected by the Write Status Register (WRSR) instruction. LB is non-volatile OTP bit, once it is set to 1, it cannot be cleared to 0. The Status Register bits are shown in shown in Figure 5 and Figure 6 and described in 10 Status Register

To write non-volatile Status Register bits, a standard Write Enable (06h) instruction must previously have been executed for the device to accept the Write Status Register (WRSR) instruction (Status Register bit WEL must equal 1). Once write enabled, the instruction is entered by driving CS# low, sending the instruction code “01h”, and then writing the status register data byte as illustrated in Figure 12 Write Status Register Instruction (SPI Mode) and Figure 133.

To write volatile Status Register bits, a Write Enable for Volatile Status Register (50h) instruction must have been executed prior to the Write Status Register (WRSR) instruction (Status Register bit WEL remains 0). However, SRP1 and LB, cannot be changed from “1” to “0” because of the OTP protection for these bits. Upon power off or the execution of a “Reset (99h)” instruction, the volatile Status Register bit values will be lost, and the non-volatile Status Register bit values will be restored.

To complete the Write Status Register (WRSR) instruction, the CS# pin must be driven high after the eighth or sixteenth bit of data that is clocked in. If this is not done the Write Status Register (WRSR) instruction will not be executed. If CS# is driven high after the eighth clock the DRV1, DRV0, CMP and QE bits will be cleared to 0.

During non-volatile Status Register write operation (06h combined with 01h), after CS# is driven high, the self-timed Write Status Register cycle will commence for a time duration of  $t_w$  (See “12.6 AC Electrical Characteristics”). While the Write Status Register cycle is in progress, the Read Status Register instruction may still be accessed to check the status of the WIP bit. The WIP bit is a 1 during the Write Status Register cycle and a 0 when the cycle is finished and ready to accept other instructions again. After the Write Status Register cycle has finished, the

Write Enable Latch (WEL) bit in the Status Register will be cleared to 0.

During volatile Status Register write operation (50h combined with 01h), after CS# is driven high, the Status Register bits will be refreshed to the new values within the time period of  $t_{SHSL2}$  (See “12.6 AC Electrical Characteristics”). WIP bit will remain 0 during the Status Register bit refresh period.

The Write Status Register (WRSR) instruction can be used in both SPI mode and QPI mode. However, the QE bit cannot be written to 0 when the device is in the QPI mode, because QE=1 is required for the device to enter and operate in the QPI mode.

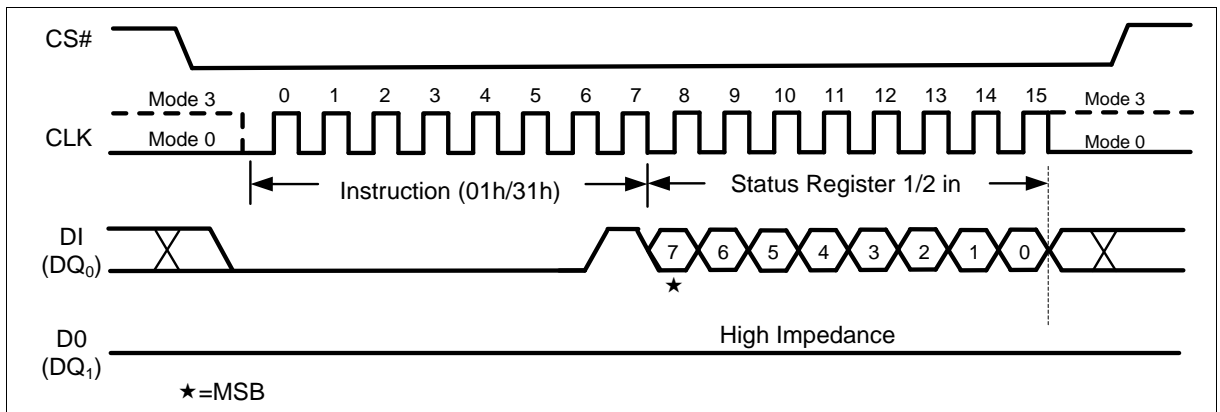

Figure 12 Write Status Register Instruction (SPI Mode)

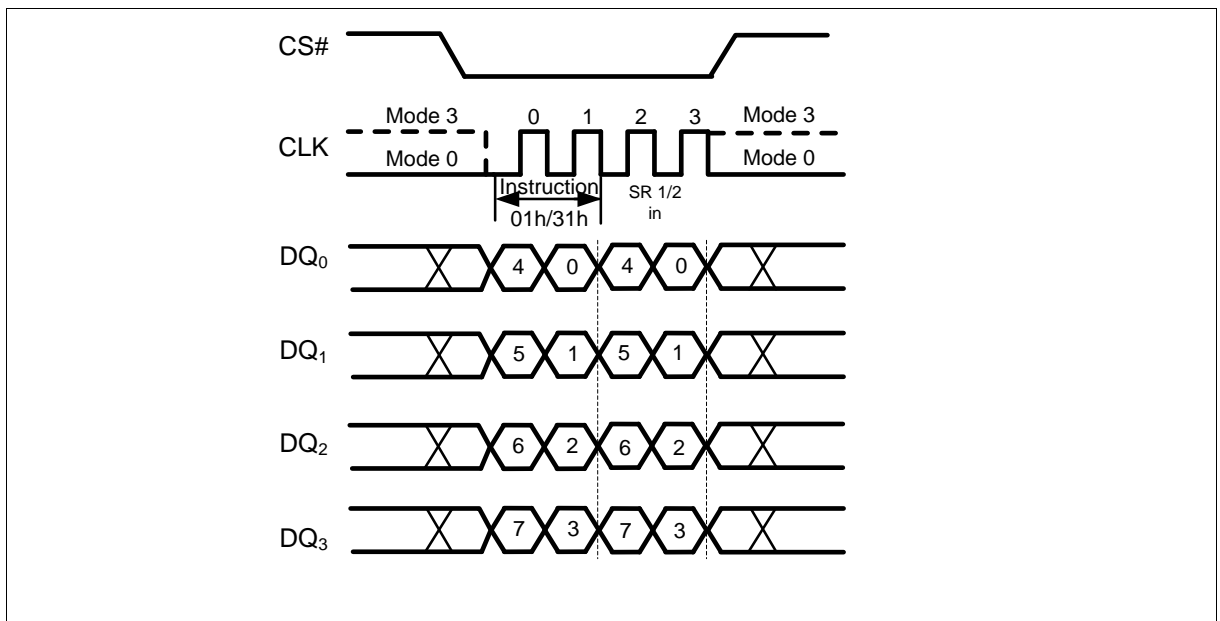

Figure 13 Write Status Register Instruction (QPI Mode)

The FM25Q64 is also backward compatible to FMSH’s previous generations of serial flash memories, in which the Status Register-1&2 can be written using a single “Write Register-1(01h)” command. To complete the Write Status Register1&2, the CS# pin must be driven high after the sixteenth bit of data that is clocked in as shown in Figure 14 & Figure 15 . If CS# is driven high after the eighth clock, the Write Status Register (WRSR) instruction will only program the Status Register-1, the Status Register-2 will not be affected.

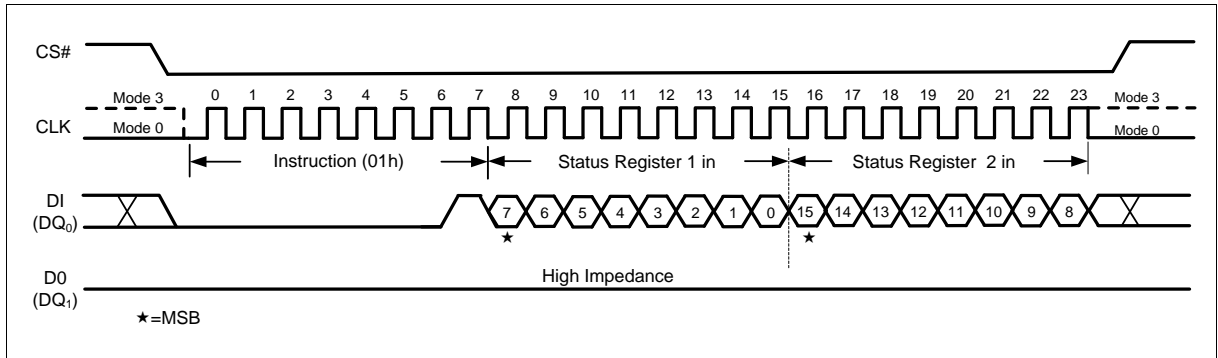

Figure 14 Write Status Register-1/2 Instruction (backward compatible, SPI Mode)

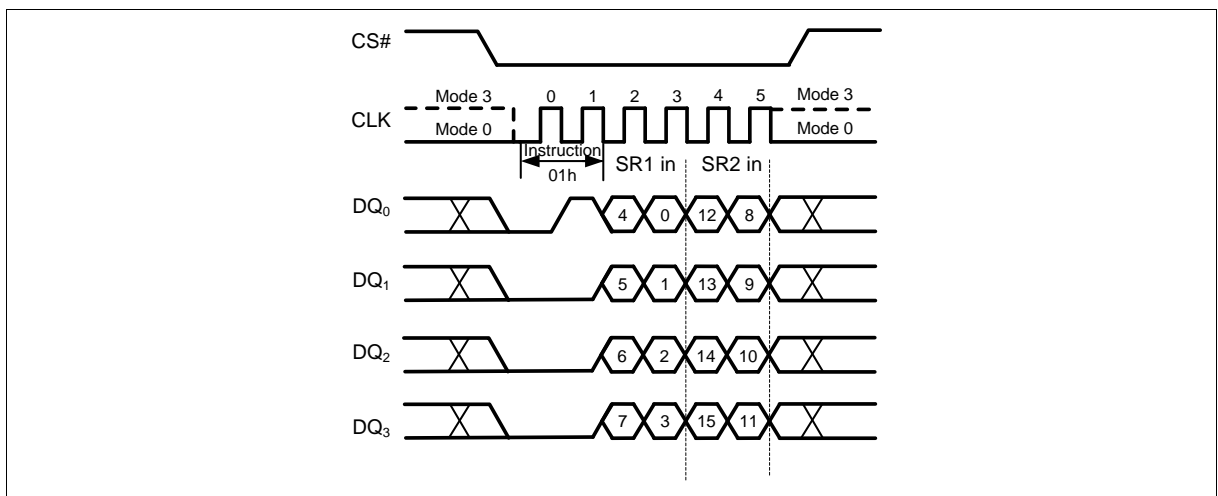

Figure 15 Write Status Register-1/2 Instruction (backward compatible, QPI Mode)

## 11.11. Read Data (03h)

The Read Data instruction allows one or more data bytes to be sequentially read from the memory. The instruction is initiated by driving the CS# pin low and then shifting the instruction code “03h” followed by a 24-bit address A23-A0 into the DI pin. The code and address bits are latched on the rising edge of the CLK pin. After the address is received, the data byte of the addressed memory location will be shifted out on the DO pin at the falling edge of CLK with most significant bit (MSB) first. The address is automatically incremented to the next higher address after each byte of data is shifted out allowing for a continuous stream of data. This means that the entire memory can be accessed with a single instruction as long as the clock continues. The instruction is completed by driving CS# high.

The Read Data instruction sequence is shown in Figure 166. If a Read Data instruction is issued while an Erase, Program or Write cycle is in process (WIP =1) the instruction is ignored and will not have any effect on the current cycle. The Read Data instruction allows clock rates from D.C. to a maximum of  $f_R$  (see “12.6 AC Electrical Characteristics”).

The Read Data (03h) instruction is only supported in Standard SPI mode.

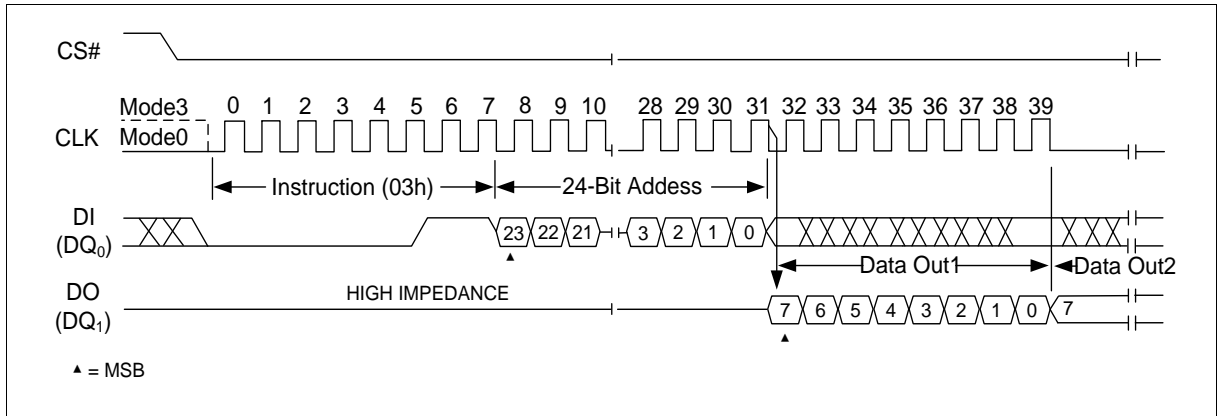

Figure 16 Read Data Instruction (SPI Mode only)

### 11.12. Fast Read (0Bh)

The Fast Read instruction is similar to the Read Data instruction except that it can operate at the highest possible frequency of  $F_R$  (see “12.6 AC Electrical Characteristics”). This is accomplished by adding eight “dummy” clocks after the 24-bit address as shown in Figure 17. The dummy clocks allow the devices internal circuits additional time for setting up the initial address. During the dummy clocks the data value on the DI pin is a “don’t care”.

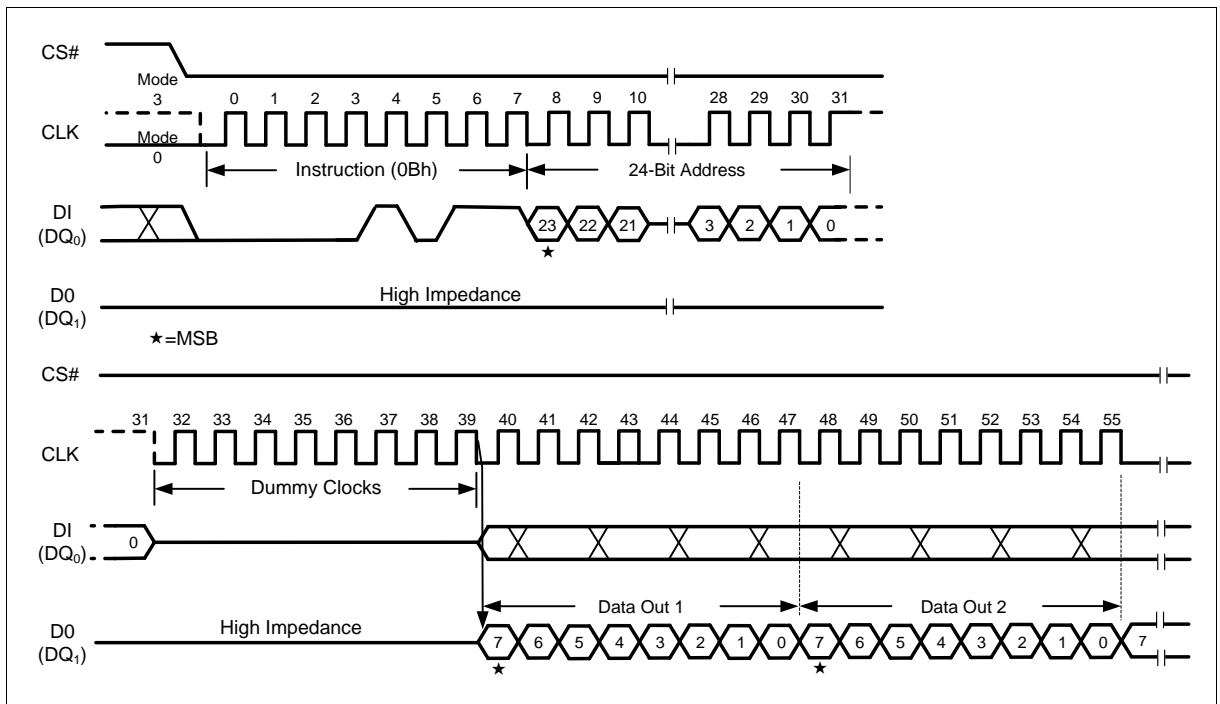

Figure 17 Fast Read Instruction (SPI Mode)

#### Fast Read (0Bh) in QPI Mode

The Fast Read instruction is also supported in QPI mode. When QPI mode is enabled, the number of dummy clocks is configured by the “Set Read Parameters (C0h)” instruction to accommodate wide range applications with different needs for either maximum Fast Read frequency or minimum data access latency. Depending on the Read Parameter Bits P[5:4] setting, the number of dummy clocks can be configured as either 2, 4, 6 or 8. The default number of dummy clocks upon power up or after a Reset instruction is 2.

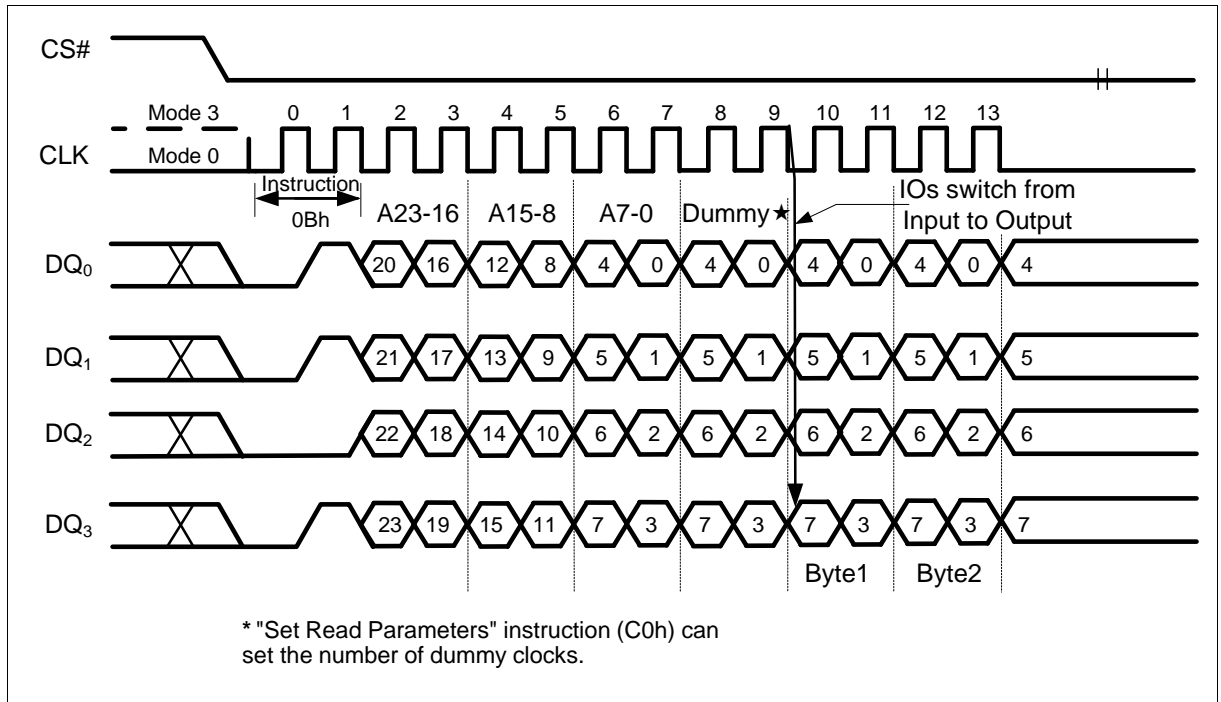

Figure 18 Fast Read Instruction (QPI Mode)

### 11.13. Fast Read Dual Output (3Bh)

The Fast Read Dual Output (3Bh) instruction is similar to the standard Fast Read (0Bh) instruction except that data is output on two pins; DQ<sub>0</sub> and DQ<sub>1</sub>. This allows data to be transferred from the FM25Q64 at twice the rate of standard SPI devices. The Fast Read Dual Output instruction is ideal for quickly downloading code from Flash to RAM upon power-up or for applications that cache code-segments to RAM for execution.

Similar to the Fast Read instruction, the Fast Read Dual Output instruction can operate at the highest possible frequency of  $F_R$  (see "12.6 AC Electrical Characteristics"). This is accomplished by adding eight "dummy" clocks after the 24-bit address as shown in Figure 19. The dummy clocks allow the device's internal circuits additional time for setting up the initial address. The input data during the dummy clocks is "don't care". However, the DQ<sub>0</sub> pin should be high-impedance prior to the falling edge of the first data out clock.

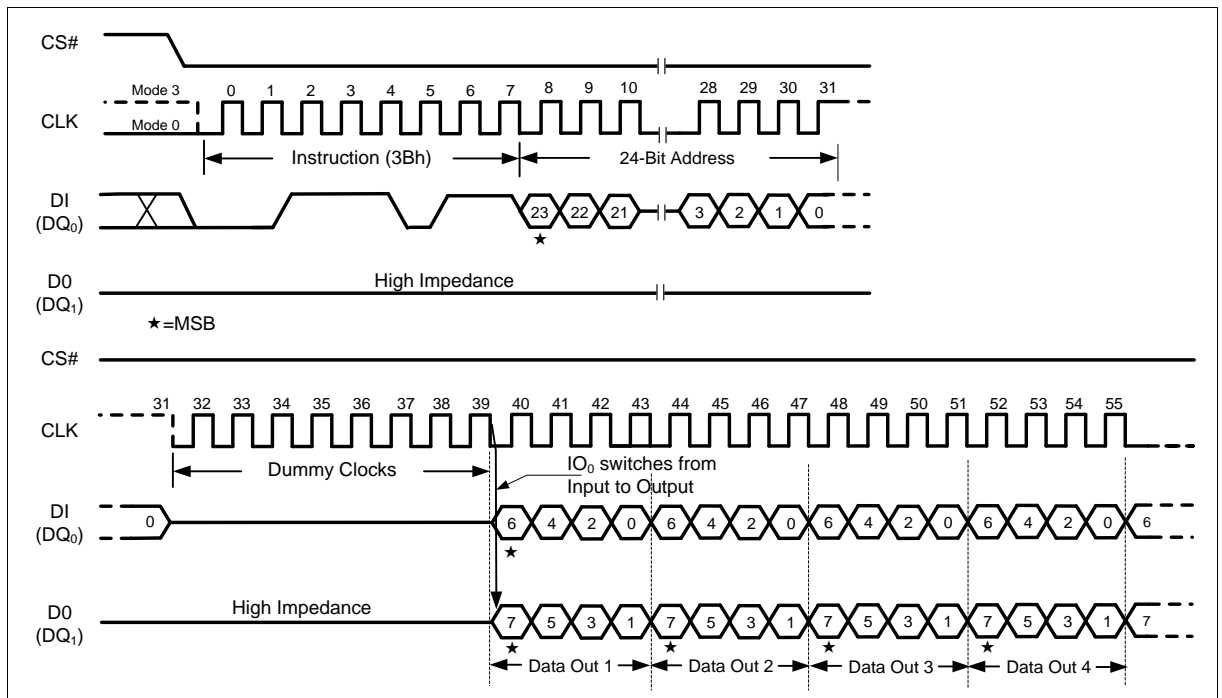

Figure 19 Fast Read Dual Output Instruction (SPI Mode only)

## 11.14. Fast Read Quad Output (6Bh)

The Fast Read Quad Output (6Bh) instruction is similar to the Fast Read Dual Output (3Bh) instruction except that data is output on four pins, DQ<sub>0</sub>, DQ<sub>1</sub>, DQ<sub>2</sub>, and DQ<sub>3</sub>. A Quad enable of Status Register-2 must be executed before the device will accept the Fast Read Quad Output Instruction (Status Register bit QE must equal 1). The Fast Read Quad Output Instruction allows data to be transferred from the FM25Q64 at four times the rate of standard SPI devices.

The Fast Read Quad Output instruction can operate at the highest possible frequency of  $F_R$  (see "12.6 AC Electrical Characteristics"). This is accomplished by adding eight "dummy" clocks after the 24-bit address as shown in Figure 200. The dummy clocks allow the device's internal circuits additional time for setting up the initial address. The input data during the dummy clocks is "don't care". However, the DQ pins should be high-impedance prior to the falling edge of the first data out clock.

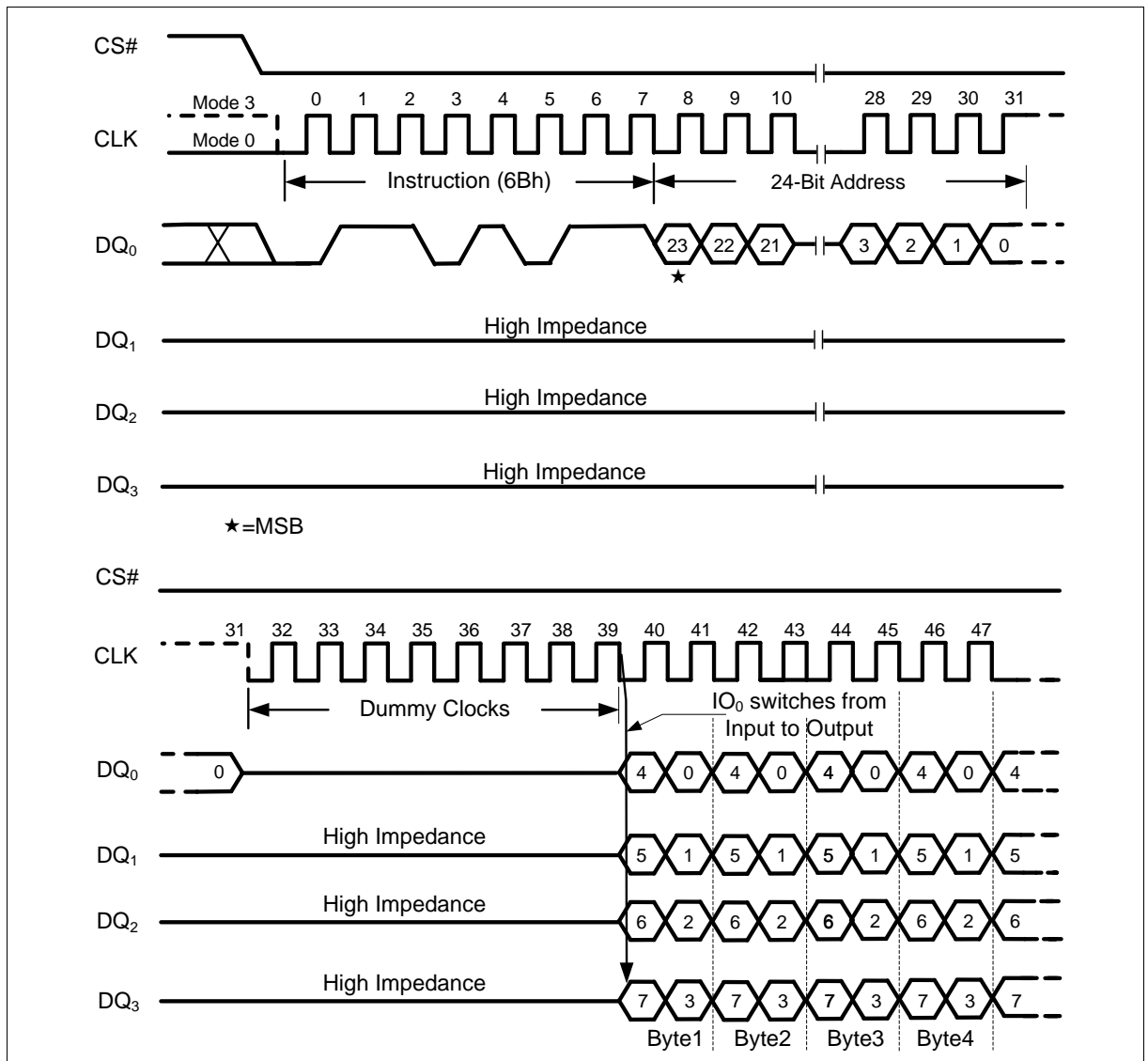

Figure 20 Fast Read Quad Output Instruction (SPI Mode only)

## 11.15. Fast Read Dual I/O (BBh)

The Fast Read Dual I/O (BBh) instruction allows for improved random access while maintaining two I/O pins, DQ<sub>0</sub> and DQ<sub>1</sub>. It is similar to the Fast Read Dual Output (3Bh) instruction but with the capability to input the Address bits A23-A0 two bits per clock. This reduced instruction overhead may allow for code execution (XIP) directly from the Dual SPI in some applications.

### Fast Read Dual I/O with “Continuous Read Mode”

The Fast Read Dual I/O instruction can further reduce instruction overhead through setting the “Continuous Read Mode” bits (M7-0) after the input Address bits A23-A0, as shown in Figure 211. The upper nibble of the (M7-4) controls the length of the next Fast Read Dual I/O instruction through the inclusion or exclusion of the first byte instruction code. The lower nibble bits of the (M3-0) are don't care (“x”). However, the DQ pins should be high-impedance prior to the falling edge of the first data out clock.

If the “Continuous Read Mode” bits M5-4 = (1,0), then the next Fast Read Dual I/O instruction (after CS# is raised and then lowered) does not require the BBh instruction code, as shown in Figure 222. This reduces the instruction sequence by eight clocks and allows the Read address

to be immediately entered after CS# is asserted low. If the “Continuous Read Mode” bits M5-4 do not equal to (1,0), the next instruction (after CS# is raised and then lowered) requires the first byte instruction code, thus returning to normal operation. It is recommended to input FFFFh on DQ<sub>0</sub> for the next

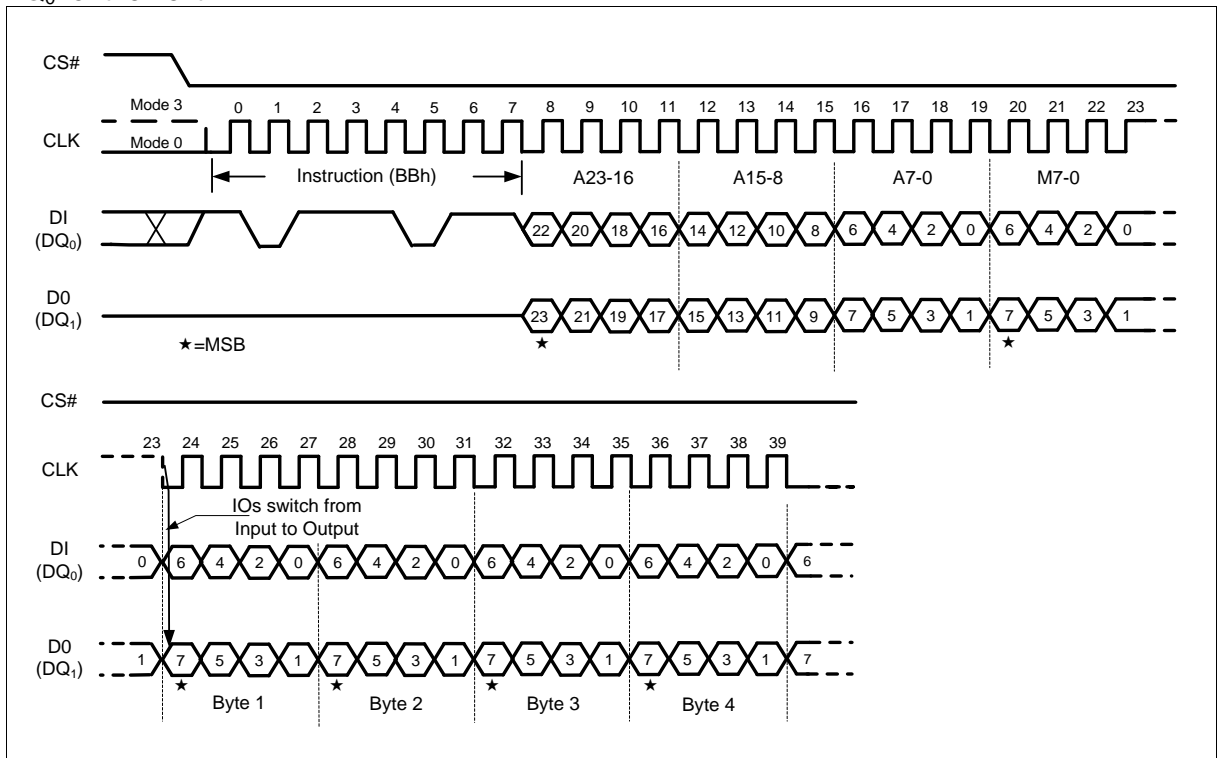

Figure 21 Fast Read Dual I/O Instruction (Initial instruction or previous M5-4 ≠ 10, SPI Mode only)

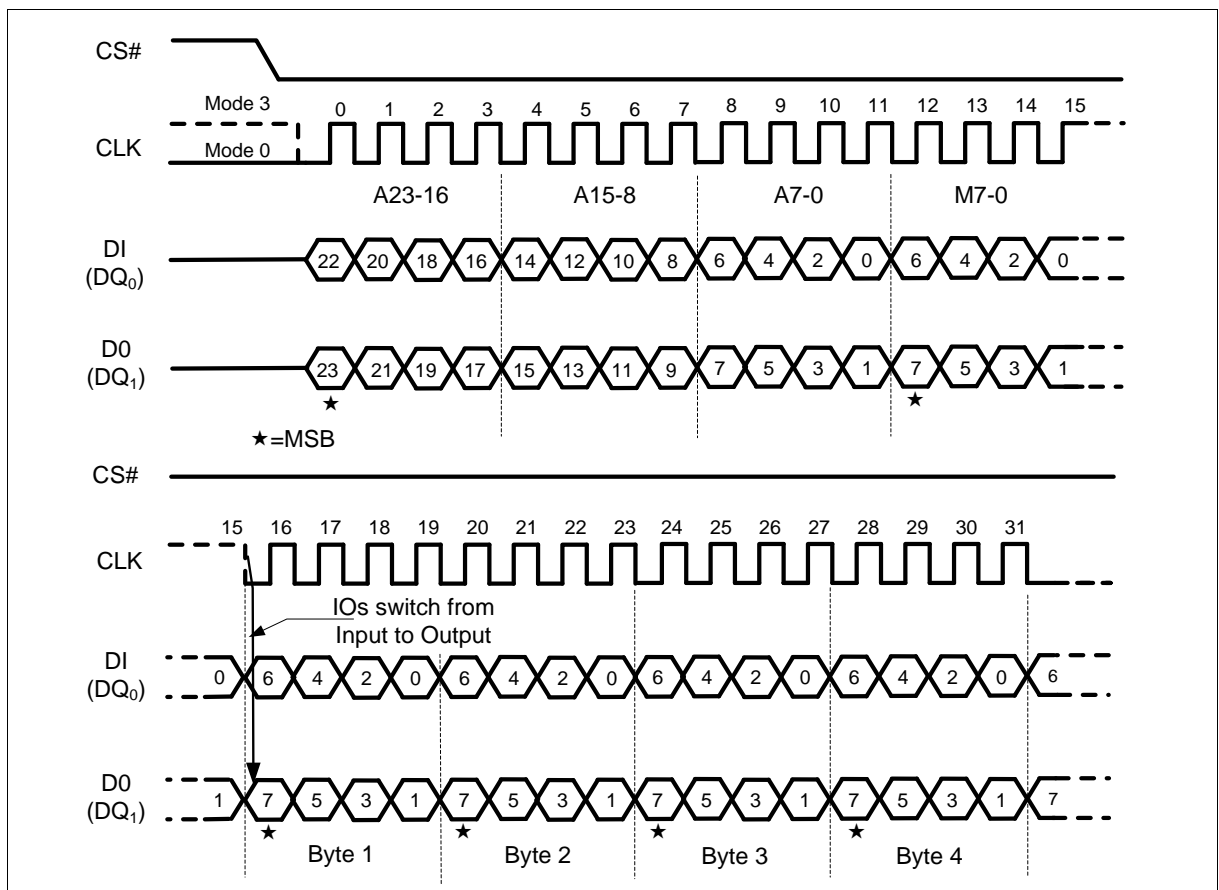

Figure 22 Fast Read Dual I/O Instruction (Previous instruction set M5-4 = 10, SPI Mode only)

## 11.16. Fast Read Quad I/O (EBh)

The Fast Read Quad I/O (EBh) instruction is similar to the Fast Read Dual I/O (BBh) instruction except that address and data bits are input and output through four pins DQ<sub>0</sub>, DQ<sub>1</sub>, DQ<sub>2</sub> and DQ<sub>3</sub> and four Dummy clocks are required in SPI mode prior to the data output. The Quad I/O dramatically reduces instruction overhead allowing faster random access for code execution (XIP) directly from the Quad SPI. The Quad Enable bit (QE) of Status Register-2 must be set to enable the Fast Read Quad I/O Instruction.

### Fast Read Quad I/O with “Continuous Read Mode”

The Fast Read Quad I/O instruction can further reduce instruction overhead through setting the “Continuous Read Mode” bits (M7-0) after the input Address bits A23-A0, as shown in Figure 233. The upper nibble of the (M7-4) controls the length of the next Fast Read Quad I/O instruction through the inclusion or exclusion of the first byte instruction code. The lower nibble bits of the (M3-0) are don't care (“x”). However, the DQ pins should be high-impedance prior to the falling edge of the first data out clock.

If the “Continuous Read Mode” bits M5-4 = (1,0), then the next Fast Read Quad I/O instruction (after CS# is raised and then lowered) does not require the EBh instruction code, as shown in Figure 244. This reduces the instruction sequence by eight clocks and allows the Read address to be immediately entered after CS# is asserted low. If the “Continuous Read Mode” bits M5-4 do not equal to (1,0), the next instruction (after CS# is raised and then lowered) requires the first byte instruction code, thus returning to normal operation. It is recommended to input FFh on DQ<sub>0</sub> for the next instruction (8 clocks), to ensure M4 = 1 and return the device to normal operation.

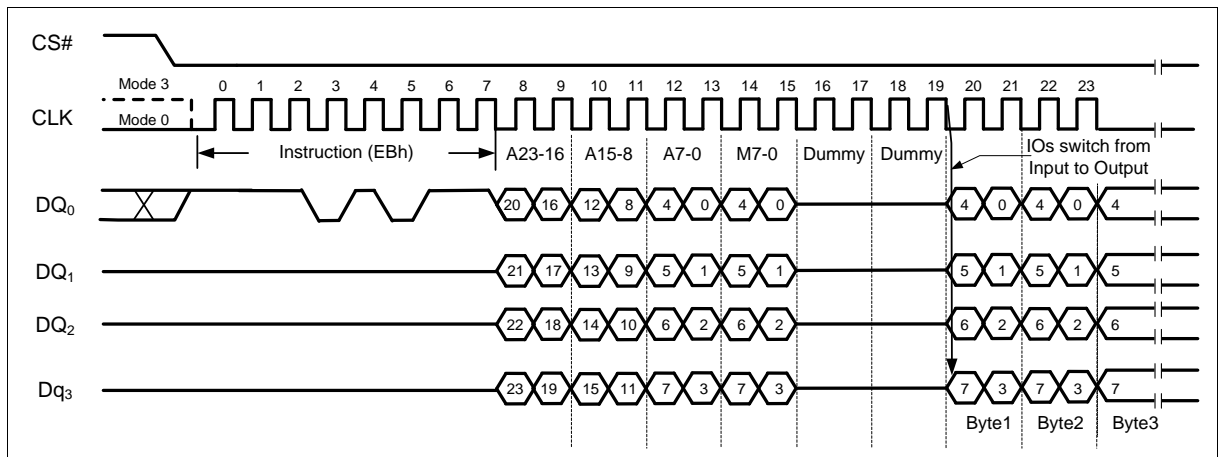

**Figure 23 Fast Read Quad I/O Instruction (Initial instruction or previous M5-4≠10, SPI Mode)**

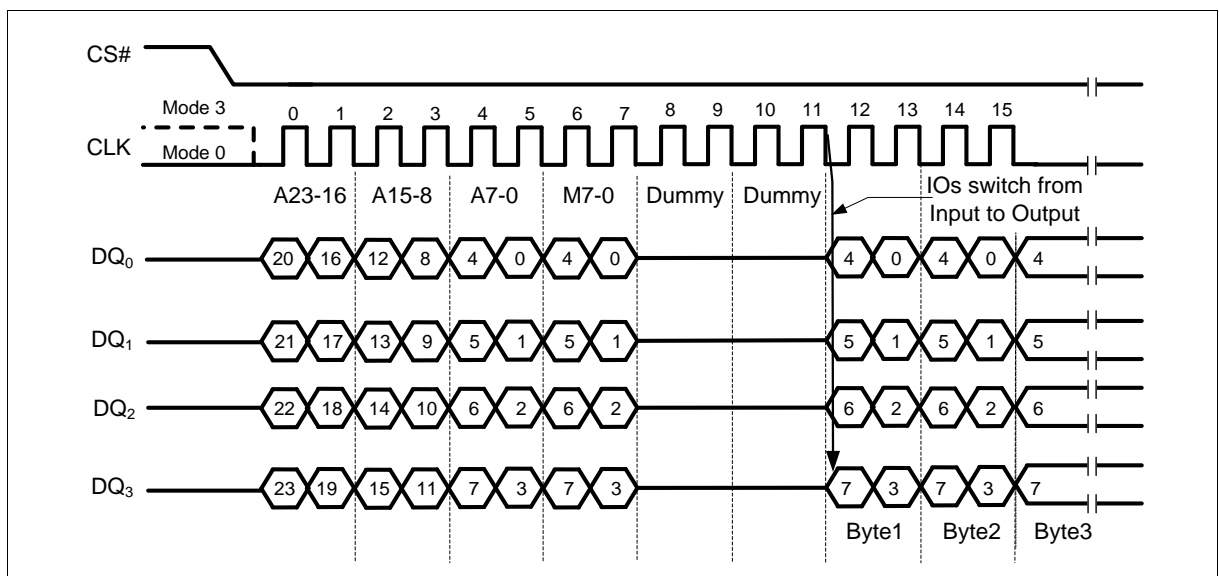

**Figure 24 Fast Read Quad I/O Instruction (Previous instruction set M5-4 = 10, SPI Mode)**

#### Fast Read Quad I/O with “8/16/32/64-Byte Wrap Around” in Standard SPI mode

The Fast Read Quad I/O instruction can also be used to access a specific portion within a page by issuing a “Set Burst with Wrap” (77h) command prior to EBh. The “Set Burst with Wrap” (77h) command can either enable or disable the “Wrap Around” feature for the following EBh commands. When “Wrap Around” is enabled, the data being accessed can be limited to either a 8, 16, 32 or 64-byte section of a 256-byte page. The output data starts at the initial address specified in the instruction, once it reaches the ending boundary of the 8/16/32/64-byte section, the output will wrap around to the beginning boundary automatically until CS# is pulled high to terminate the command.

The Burst with Wrap feature allows applications that use cache to quickly fetch a critical address and then fill the cache afterwards within a fixed length (8/16/32/64-byte) of data without issuing multiple read commands.

The “Set Burst with Wrap” instruction allows three “Wrap Bits”, W6-4 to be set. The W4 bit is used to enable or disable the “Wrap Around” operation while W6-5 are used to specify the length of the wrap around section within a page. See “11.19 Set Burst with Wrap (77h)” for detail descriptions.

### Fast Read Quad I/O (EBh) in QPI Mode

The Fast Read Quad I/O instruction is also supported in QPI mode, as shown in Figure 255. When QPI mode is enabled, the number of dummy clocks is configured by the “Set Read Parameters (C0h)” instruction to accommodate a wide range application with different needs for either maximum Fast Read frequency or minimum data access latency. Depending on the Read Parameter Bits P[5:4] setting, the number of dummy clocks can be configured as either 2, 4, 6 or 8. The default number of dummy clocks upon power up or after a Reset instruction is 2. In QPI mode, the “Continuous Read Mode” bits M7-0 are also considered as dummy clocks. In the default setting, the data output will follow the Continuous Read Mode bits immediately.

“Continuous Read Mode” feature is also available in QPI mode for Fast Read Quad I/O instruction. Please refer to the description on previous pages.

“Wrap Around” feature is not available in QPI mode for Fast Read Quad I/O instruction. To perform a read operation with fixed data length wrap around in QPI mode, a dedicated “Burst Read with Wrap” (0Ch) instruction must be used. Please refer to “11.40 Burst Read with Wrap (0Ch)” for details.

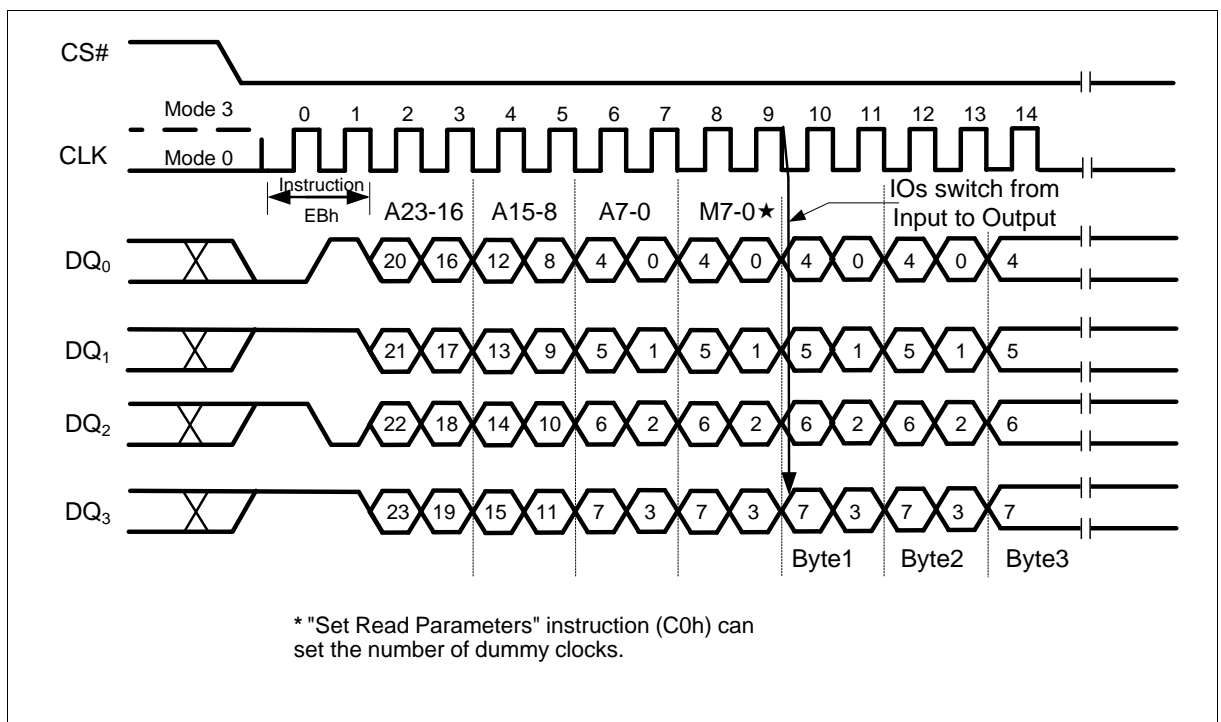

Figure 25 Fast Read Quad I/O Instruction (Initial instruction or previous M5-4#10, QPI Mode)

## 11.17. Word Read Quad I/O (E7h)

The Word Read Quad I/O (E7h) instruction is similar to the Fast Read Quad I/O (EBh) instruction except that the lowest Address bit (A0) must equal 0 and only two Dummy clock are required prior to the data output. The Quad I/O dramatically reduces instruction overhead allowing faster random access for code execution (XIP) directly from the Quad SPI. The Quad Enable bit (QE) of Status Register-2 must be set to enable the Word Read Quad I/O Instruction.

### Word Read Quad I/O with “Continuous Read Mode”

The Word Read Quad I/O instruction can further reduce instruction overhead through setting the “Continuous Read Mode” bits (M7-0) after the input Address bits A23-A0, as shown in Figure 26.

The upper nibble of the (M7-4) controls the length of the next Fast Read Quad I/O instruction through the inclusion or exclusion of the first byte instruction code. The lower nibble bits of the (M3-0) are don't care ("x"). However, the DQ pins should be high-impedance prior to the falling edge of the first data out clock.

If the "Continuous Read Mode" bits M5-4 = (1,0), then the next Fast Read Quad I/O instruction (after CS# is raised and then lowered) does not require the E7h instruction code, as shown in Figure 27. This reduces the instruction sequence by eight clocks and allows the Read address to be immediately entered after CS# is asserted low. If the "Continuous Read Mode" bits M5-4 do not equal to (1,0), the next instruction (after CS# is raised and then lowered) requires the first byte instruction code, thus returning to normal operation. It is recommended to input FFh on DQ<sub>0</sub> for the next instruction (8 clocks), to ensure M4 = 1 and return the device to normal operation.

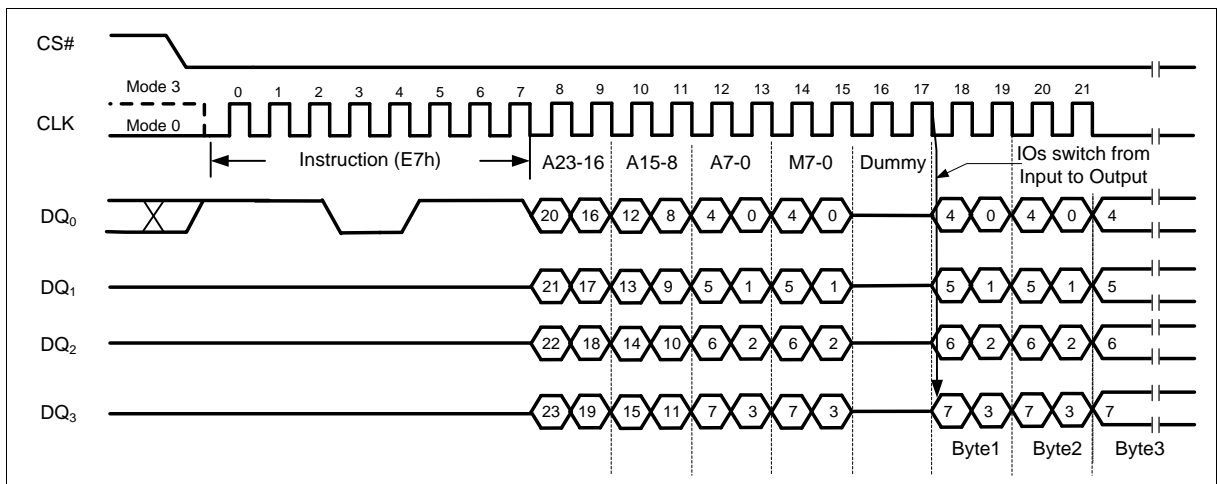

Figure 26 Word Read Quad I/O Instruction (Initial instruction or previous M5-4 ≠ 10, SPI Mode only)

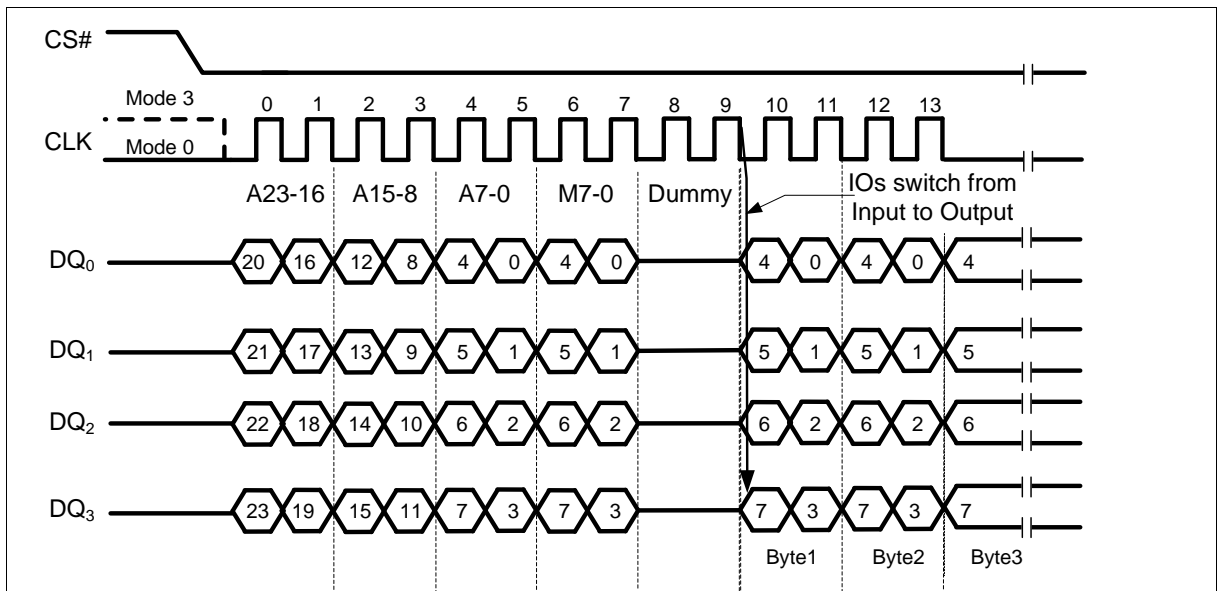

Figure 27 Word Read Quad I/O Instruction (Previous instruction set M5-4 = 10, SPI Mode only)

**Word Read Quad I/O with "8/16/32/64-Byte Wrap Around" in Standard SPI mode**

The Word Read Quad I/O instruction can also be used to access a specific portion within a page by issuing a "Set Burst with Wrap" (77h) command prior to E7h. The "Set Burst with Wrap" (77h)

command can either enable or disable the “Wrap Around” feature for the following E7h commands. When “Wrap Around” is enabled, the data being accessed can be limited to either a 8, 16, 32 or 64-byte section of a 256-byte page. The output data starts at the initial address specified in the instruction, once it reaches the ending boundary of the 8/16/32/64-byte section, the output will wrap around to the beginning boundary automatically until CS# is pulled high to terminate the command.

The Burst with Wrap feature allows applications that use cache to quickly fetch a critical address and then fill the cache afterwards within a fixed length (8/16/32/64-byte) of data without issuing multiple read commands.

The “Set Burst with Wrap” instruction allows three “Wrap Bits”, W6-4 to be set. The W4 bit is used to enable or disable the “Wrap Around” operation while W6-5 are used to specify the length of the wrap around section within a page. See “11.19 Set Burst with Wrap (77h)” for detail descriptions.

## 11.18. Octal Word Read Quad I/O (E3h)

The Octal Word Read Quad I/O (E3h) instruction is similar to the Fast Read Quad I/O (EBh) instruction except that the lower four Address bits (A0, A1, A2, A3) must equal 0. As a result, the dummy clocks are not required, which further reduces the instruction overhead allowing even faster random access for code execution (XIP). The Quad Enable bit (QE) of Status Register-2 must be set to enable the Octal Word Read Quad I/O Instruction.

### Octal Word Read Quad I/O with “Continuous Read Mode”

The Octal Word Read Quad I/O instruction can further reduce instruction overhead through setting the “Continuous Read Mode” bits M7-M0 after the input Address bits A23-A0, as shown in Figure 28. The upper nibble of the (M7-4) controls the length of the next Octal Word Read Quad I/O instruction through the inclusion or exclusion of the first byte instruction code. The lower nibble bits of the (M3-0) are don't care (“x”). However, the DQ pins should be high-impedance prior to the falling edge of the first data out clock.

If the “Continuous Read Mode” bits M5-4 = (1, 0), then the next Fast Read Quad I/O instruction (after CS# is raised and then lowered) does not require the E3h instruction code, as shown in Figure 29. This reduces the instruction sequence by eight clocks and allows the Read address to be immediately entered after CS# is asserted low. If the “Continuous Read Mode” bits M5-4 do not equal to (1, 0), the next instruction (after CS# is raised and then lowered) requires the first byte instruction code, thus returning to normal operation. It is recommended to input FFh on DQ<sub>0</sub> for the next instruction (8 clocks), to ensure M4 = 1 and return the device to normal operation.

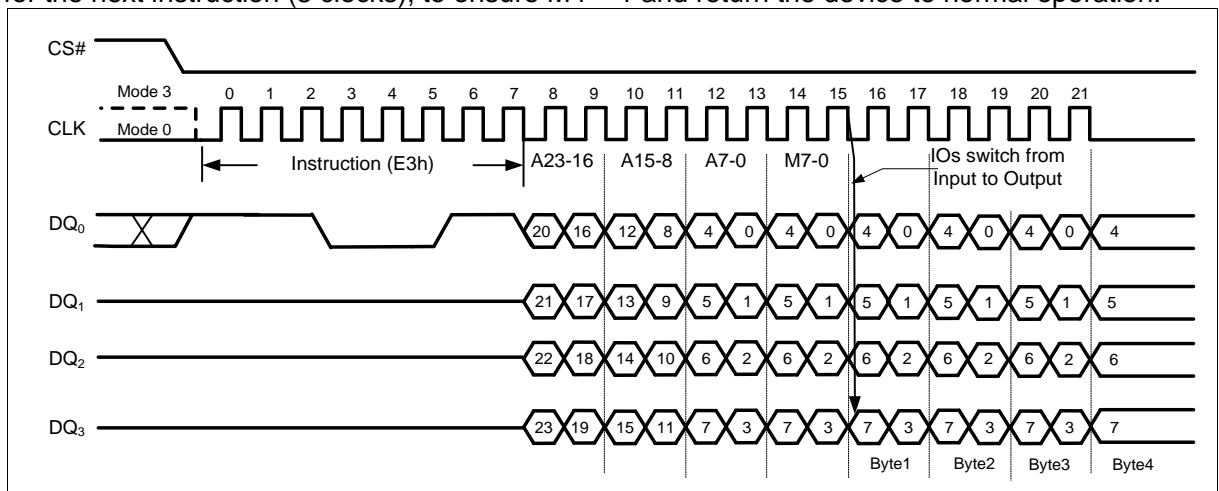
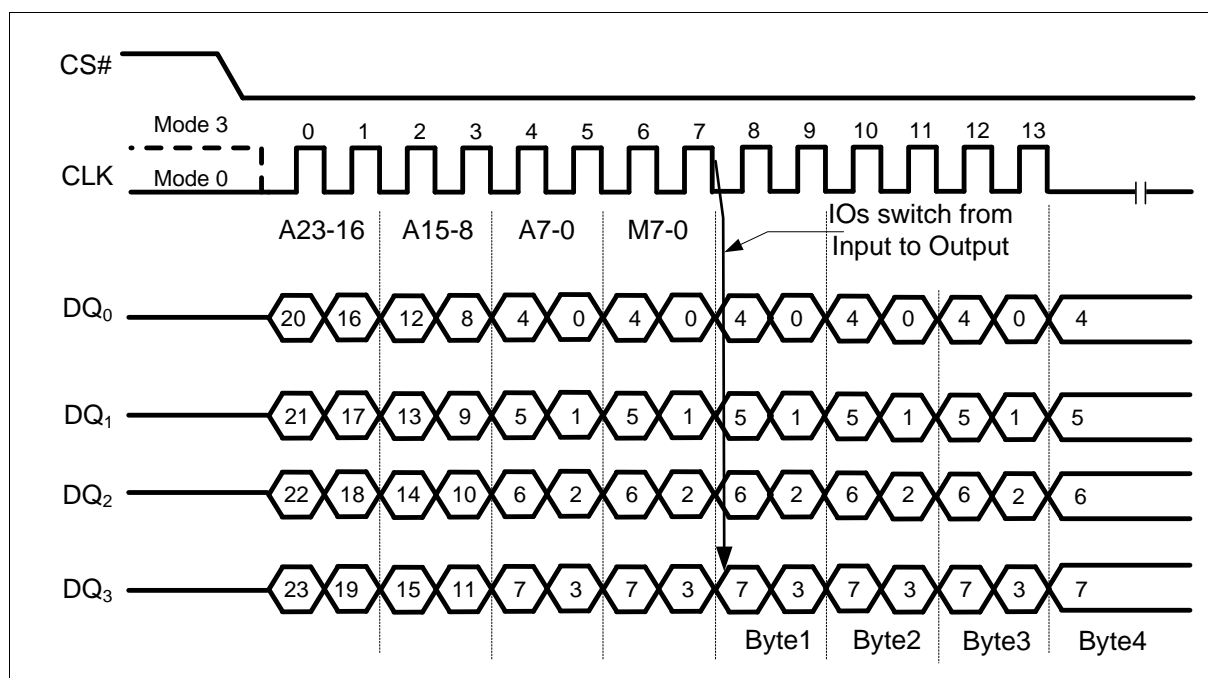

Figure 28 Octal Word Read Quad I/O Instruction (Initial instruction or previous M5-4 ≠ 10, SPI Mode only)



**Figure 29 Octal Word Read Quad I/O Instruction (Previous instruction set M5-4 = 10, SPI Mode only)**

## 11.19. Set Burst with Wrap (77h)

In Standard SPI mode, the Set Burst with Wrap (77h) instruction is used in conjunction with “Fast Read Quad I/O” and “Word Read Quad I/O” instructions to access a fixed length of 8/16/32/64-byte section within a 256-byte page. Certain applications can benefit from this feature and improve the overall system code execution performance.

Similar to a Quad I/O instruction, the Set Burst with Wrap instruction is initiated by driving the CS# pin low and then shifting the instruction code “77h” followed by 24 dummy bits and 8 “Wrap Bits”, W7-0. The instruction sequence is shown in Figure 30. Wrap bit W7 and the lower nibble W3-0 are not used.

W6, W5	W4 = 0		W4 = 1 (default)	
	Wrap Around	Wrap Length	Wrap Around	Wrap Length
0 0	Yes	8-byte	No	N/A
0 1	Yes	16-byte	No	N/A
1 0	Yes	32-byte	No	N/A
1 1	Yes	64-byte	No	N/A

Once W6-4 is set by a Set Burst with Wrap instruction, all the following “Fast Read Quad I/O” and “Word Read Quad I/O” instructions will use the W6-4 setting to access the 8/16/32/64-byte section within any page. To exit the “Wrap Around” function and return to normal read operation, another Set Burst with Wrap instruction should be issued to set W4 = 1. The default value of W4 upon power on is 1. In the case of a system Reset while W4 = 0, it is recommended that the controller issues a Set Burst with Wrap instruction to reset W4 = 1 prior to any normal Read instructions since FM25Q64 does not have a hardware Reset Pin.

In QPI mode, the “Burst Read with Wrap (0Ch)” instruction should be used to perform the Read operation with “Wrap Around” feature. The Wrap Length set by W5-4 in Standard SPI mode is still

valid in QPI mode and can also be re-configured by “Set Read Parameters (C0h)” instruction. Refer to “11.39 Set Read Parameters (C0h)” and “11.40 Burst Read with Wrap (0Ch)” for details.

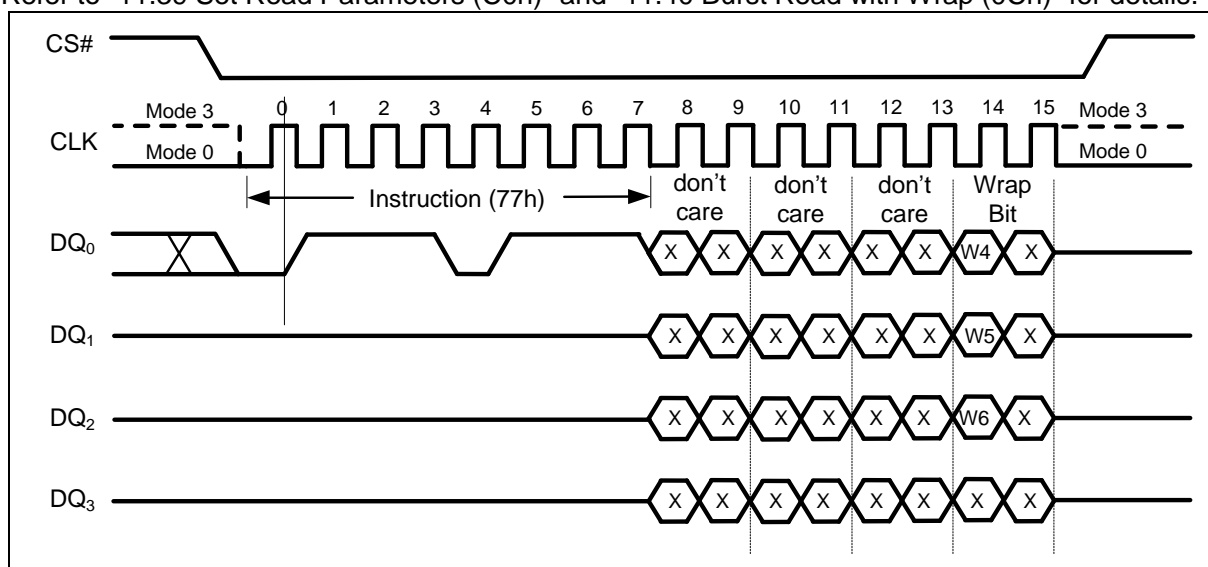

Figure 30 Set Burst with Wrap Instruction (SPI Mode only)

## 11.20. Page Program (02h)

The Page Program instruction allows from one byte to 256 bytes (a page) of data to be programmed at previously erased (FFh) memory locations. A Write Enable instruction must be executed before the device will accept the Page Program Instruction (Status Register bit WEL= 1). The instruction is initiated by driving the CS# pin low then shifting the instruction code “02h” followed by a 24-bit address A23-A0 and at least one data byte, into the DI pin. The CS# pin must be held low for the entire length of the instruction while data is being sent to the device. The Page Program instruction sequence is shown in Figure 31 and Figure 32.

If an entire 256 byte page is to be programmed, the last address byte (the 8 least significant address bits) should be set to 0. If the last address byte is not zero, and the number of clocks exceeds the remaining page length, the addressing will wrap to the beginning of the page. In some cases, less than 256 bytes (a partial page) can be programmed without having any effect on other bytes within the same page. One condition to perform a partial page program is that the number of clocks can not exceed the remaining page length. If more than 256 bytes are sent to the device the addressing will wrap to the beginning of the page and overwrite previously sent data.

As with the write and erase instructions, the CS# pin must be driven high after the eighth bit of the last byte has been latched. If this is not done the Page Program instruction will not be executed. After CS# is driven high, the self-timed Page Program instruction will commence for a time duration of  $t_{PP}$  (See “12.6 AC Electrical Characteristics”). While the Page Program cycle is in progress, the Read Status Register instruction may still be accessed for checking the status of the WIP bit. The WIP bit is a 1 during the Page Program cycle and becomes a 0 when the cycle is finished and the device is ready to accept other instructions again. After the Page Program cycle has finished the Write Enable Latch (WEL) bit in the Status Register is cleared to 0. The Page Program instruction will not be executed if the addressed page is protected by the Block Protect (CMP, SEC, TB, BP2, BP1, and BP0) bits.

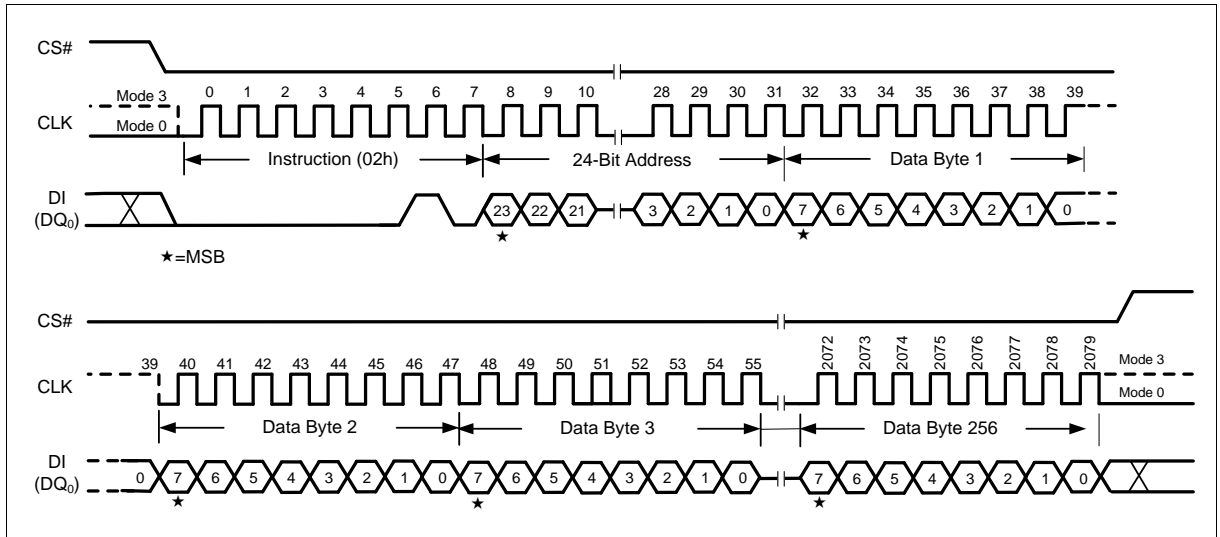

Figure 31 Page Program Instruction (SPI Mode)

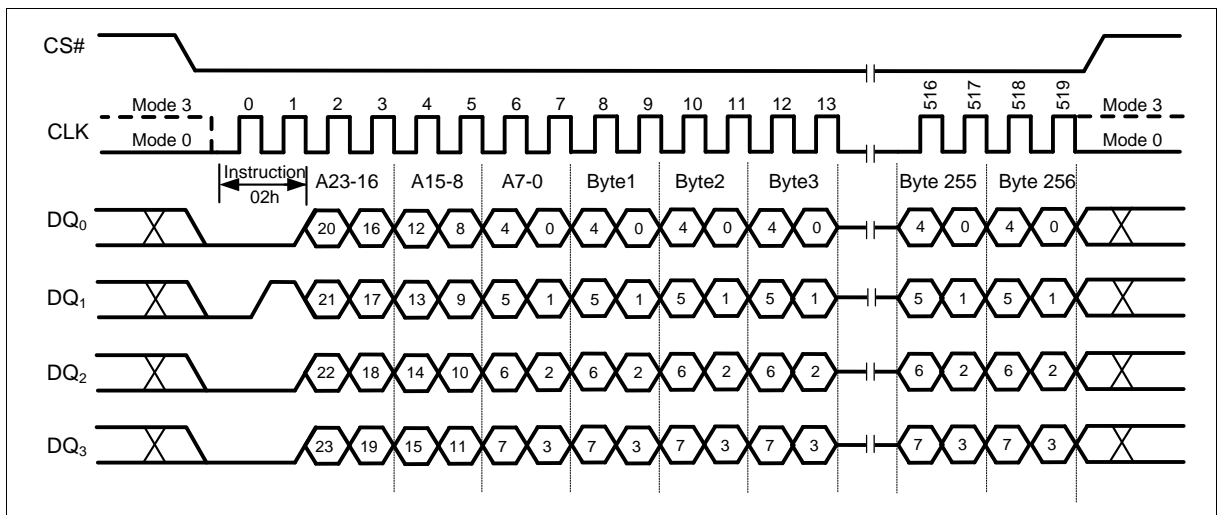

Figure 32 Page Program Instruction (QPI Mode)

### 11.21. Quad Input Page Program (32h)

The Quad Page Program instruction allows up to 256 bytes of data to be programmed at previously erased (FFh) memory locations using four pins: DQ<sub>0</sub>, DQ<sub>1</sub>, DQ<sub>2</sub>, and DQ<sub>3</sub>. The Quad Page Program can improve performance for PROM Programmer and applications that have slow clock speeds <5MHz. Systems with faster clock speed will not realize much benefit for the Quad Page Program instruction since the inherent page program time is much greater than the time it take to clock-in the data.

To use Quad Page Program the Quad Enable in Status Register-2 must be set (QE=1). A Write Enable instruction must be executed before the device will accept the Quad Page Program instruction (Status Register-1, WEL=1). The instruction is initiated by driving the CS# pin low then shifting the instruction code “32h” followed by a 24-bit address A23-A0 and at least one data byte, into the DQ pins. The CS# pin must be held low for the entire length of the instruction while data is being sent to the device. All other functions of Quad Page Program are identical to standard Page Program. The Quad Page Program instruction sequence is shown in Figure 33.

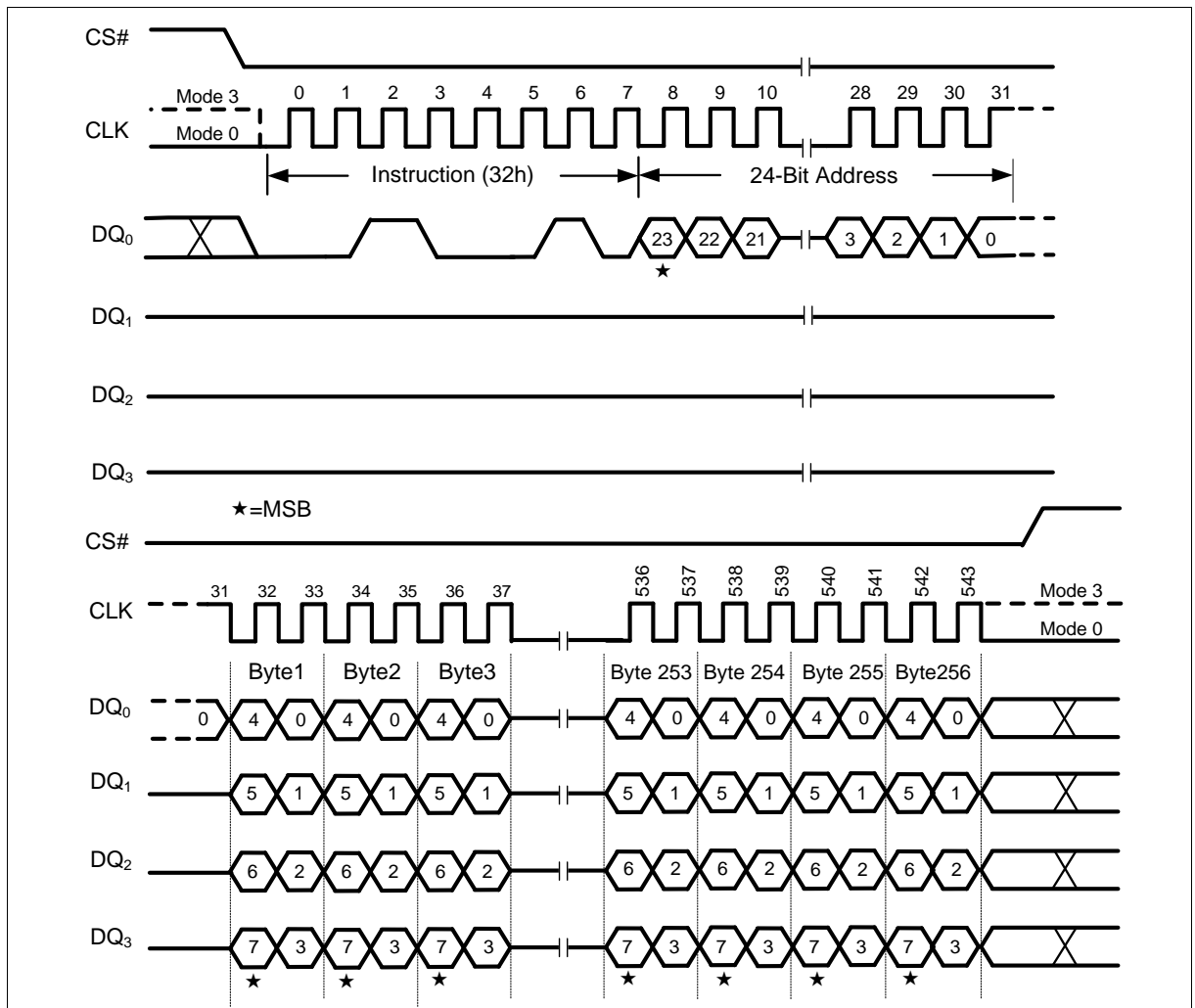

Figure 33 Quad Input Page Program Instruction (SPI Mode only)

## 11.22. Sector Erase (20h)

The Sector Erase instruction sets all memory within a specified sector (4K-bytes) to the erased state of all 1s (FFh). A Write Enable instruction must be executed before the device will accept the Sector Erase Instruction (Status Register bit WEL must equal 1). The instruction is initiated by driving the CS# pin low and shifting the instruction code “20h” followed a 24-bit sector address A23-A0 (see Figure 1). The Sector Erase instruction sequence is shown in Figure 34 & Figure 35.

The CS# pin must be driven high after the eighth bit of the last byte has been latched. If this is not done the Sector Erase instruction will not be executed. After CS# is driven high, the self-timed Sector Erase instruction will commence for a time duration of  $t_{SE}$  (See “12.6 AC Electrical Characteristics”). While the Sector Erase cycle is in progress, the Read Status Register instruction may still be accessed for checking the status of the WIP bit. The WIP bit is a 1 during the Sector Erase cycle and becomes a 0 when the cycle is finished and the device is ready to accept other instructions again. After the Sector Erase cycle has finished the Write Enable Latch (WEL) bit in the Status Register is cleared to 0. The Sector Erase instruction will not be executed if the addressed page is protected by the Block Protect (CMP, SEC, TB, BP2, BP1, and BP0) bits (see Table 3 Status Register Memory Protection table).

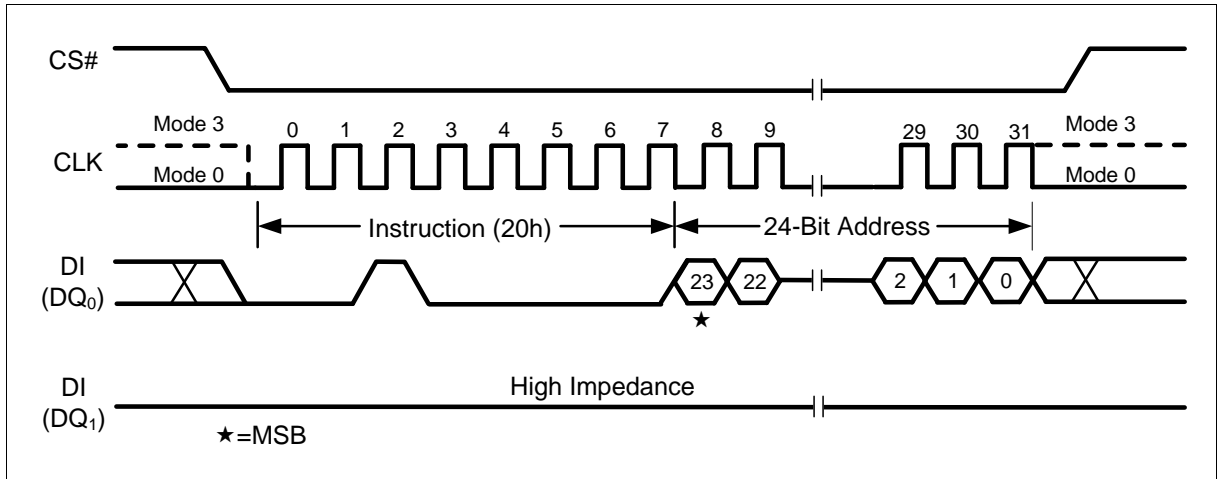

Figure 34 Sector Erase Instruction (SPI Mode)

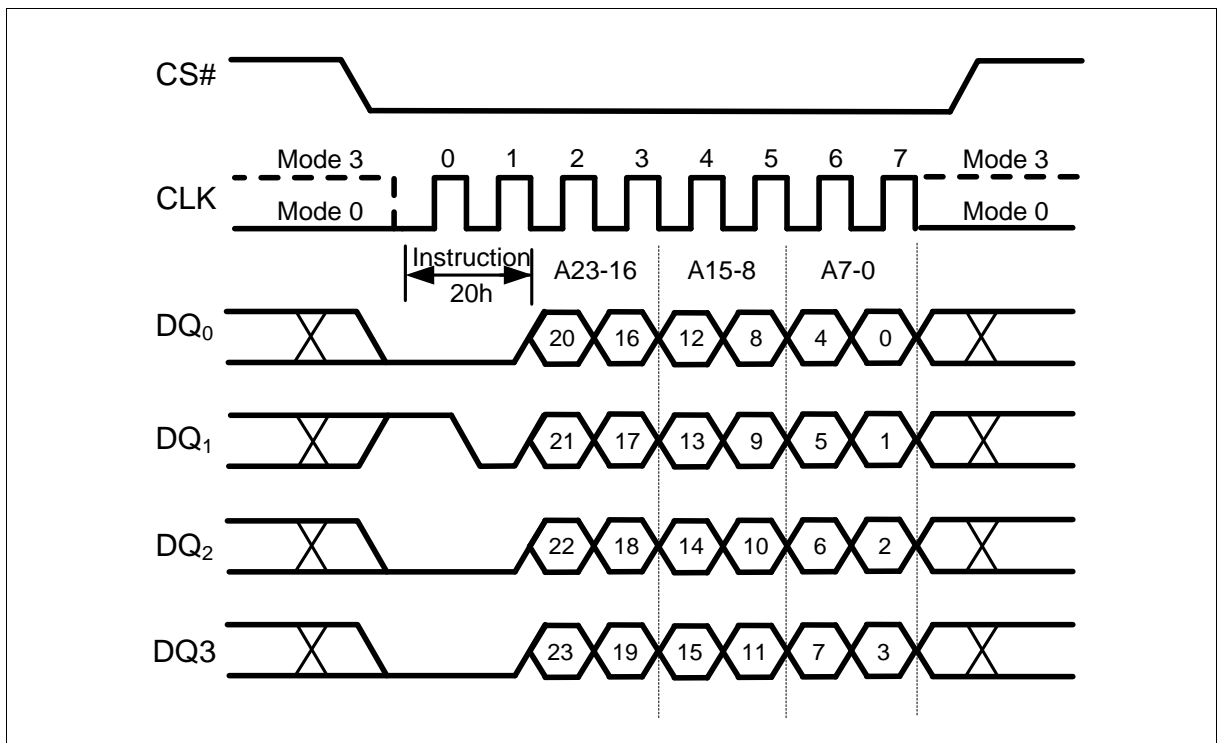

Figure 35 Sector Erase Instruction (QPI Mode)

### 11.23. 32KB Block Erase (BE32) (52h)

The 32KB Block Erase instruction sets all memory within a specified block (32K-bytes) to the erased state of all 1s (FFh). A Write Enable instruction must be executed before the device will accept the Block Erase Instruction (Status Register bit WEL must equal 1). The instruction is initiated by driving the CS# pin low and shifting the instruction code "52h" followed a 24-bit block address A23-A0. The Block Erase instruction sequence is shown in Figure 36 & Figure 37.

The CS# pin must be driven high after the eighth bit of the last byte has been latched. If this is not done the Block Erase instruction will not be executed. After CS# is driven high, the self-timed Block Erase instruction will commence for a time duration of  $t_{BE1}$  (See "12.6 AC Electrical Characteristics"). While the Block Erase cycle is in progress, the Read Status Register instruction may still be accessed for checking the status of the WIP bit. The WIP bit is a 1 during the Block

Erase cycle and becomes a 0 when the cycle is finished and the device is ready to accept other instructions again. After the Block Erase cycle has finished the Write Enable Latch (WEL) bit in the Status Register is cleared to 0. The Block Erase instruction will not be executed if the addressed page is protected by the Block Protect (CMP, SEC, TB, BP2, BP1, and BP0) bits (see Table 3 Status Register Memory Protection table).

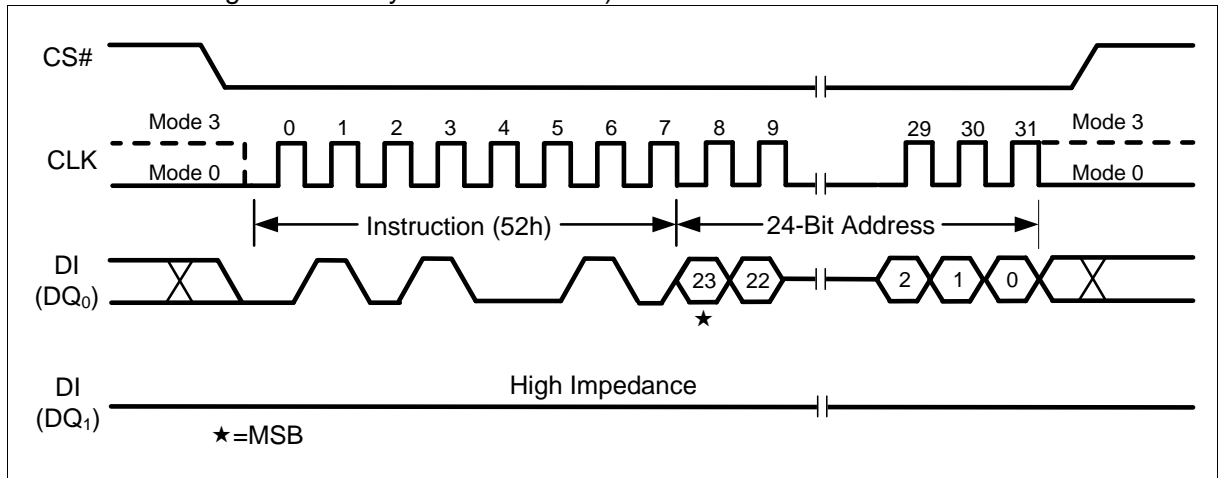

Figure 36 32KB Block Erase Instruction (SPI Mode)

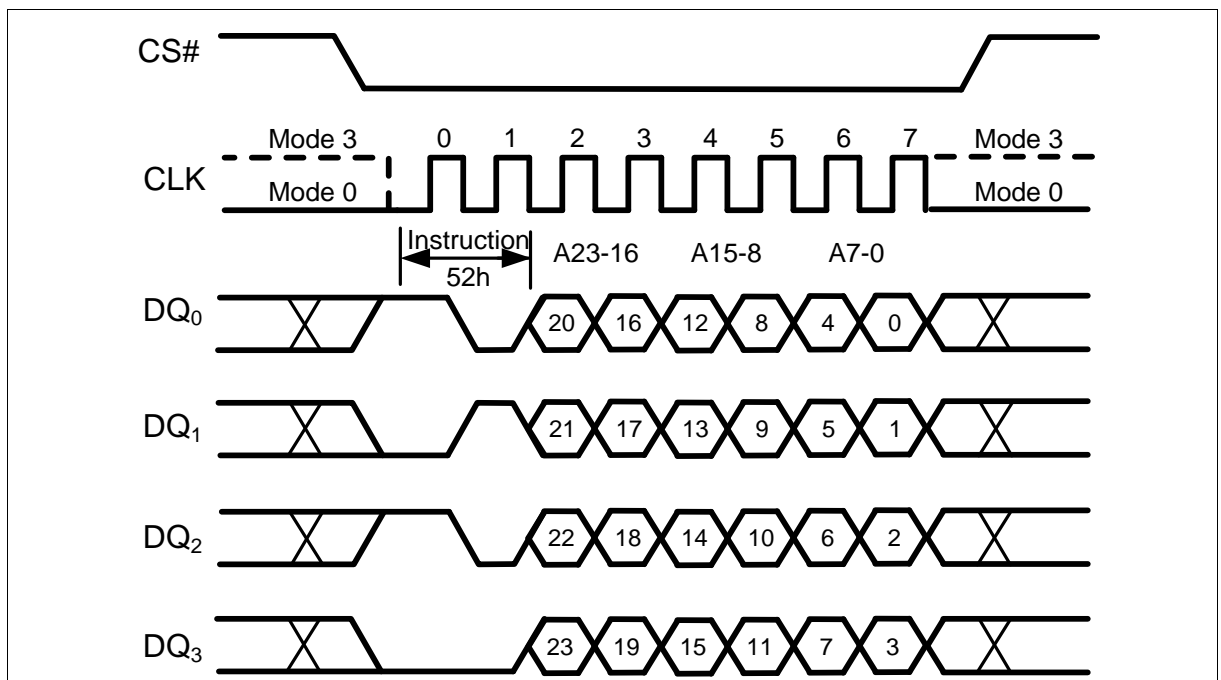

Figure 37 32KB Block Erase Instruction (QPI Mode)

### 11.24. 64KB Block Erase (BE) (D8h)

The 64KB Block Erase instruction sets all memory within a specified block (64K-bytes) to the erased state of all 1s (FFh). A Write Enable instruction must be executed before the device will accept the Block Erase Instruction (Status Register bit WEL must equal 1). The instruction is initiated by driving the CS# pin low and shifting the instruction code “D8h” followed a 24-bit block address A<sub>23-A0</sub>. The Block Erase instruction sequence is shown in Figure 38 & Figure 39.

The CS# pin must be driven high after the eighth bit of the last byte has been latched. If this is not done the Block Erase instruction will not be executed. After CS# is driven high, the self-timed

Block Erase instruction will commence for a time duration of  $t_{BE}$  (See 12.6 AC Electrical Characteristics”). While the Block Erase cycle is in progress, the Read Status Register instruction may still be accessed for checking the status of the WIP bit. The WIP bit is a 1 during the Block Erase cycle and becomes a 0 when the cycle is finished and the device is ready to accept other instructions again. After the Block Erase cycle has finished the Write Enable Latch (WEL) bit in the Status Register is cleared to 0. The Block Erase instruction will not be executed if the addressed page is protected by the Block Protect (CMP, SEC, TB, BP2, BP1, and BP0) bits (see Table 3 Status Register Memory Protection table).

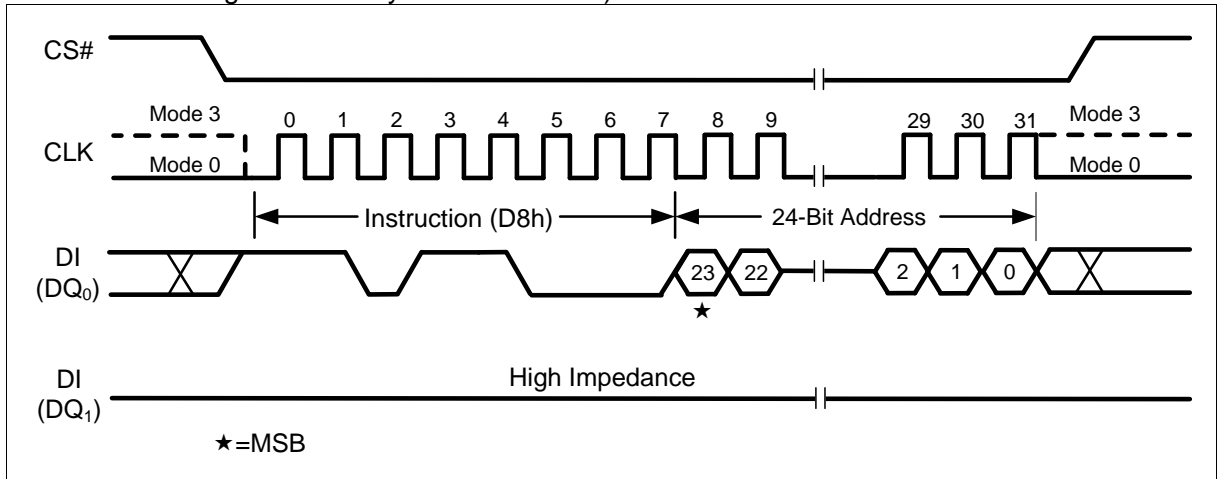

Figure 38 64KB Block Erase Instruction (SPI Mode)

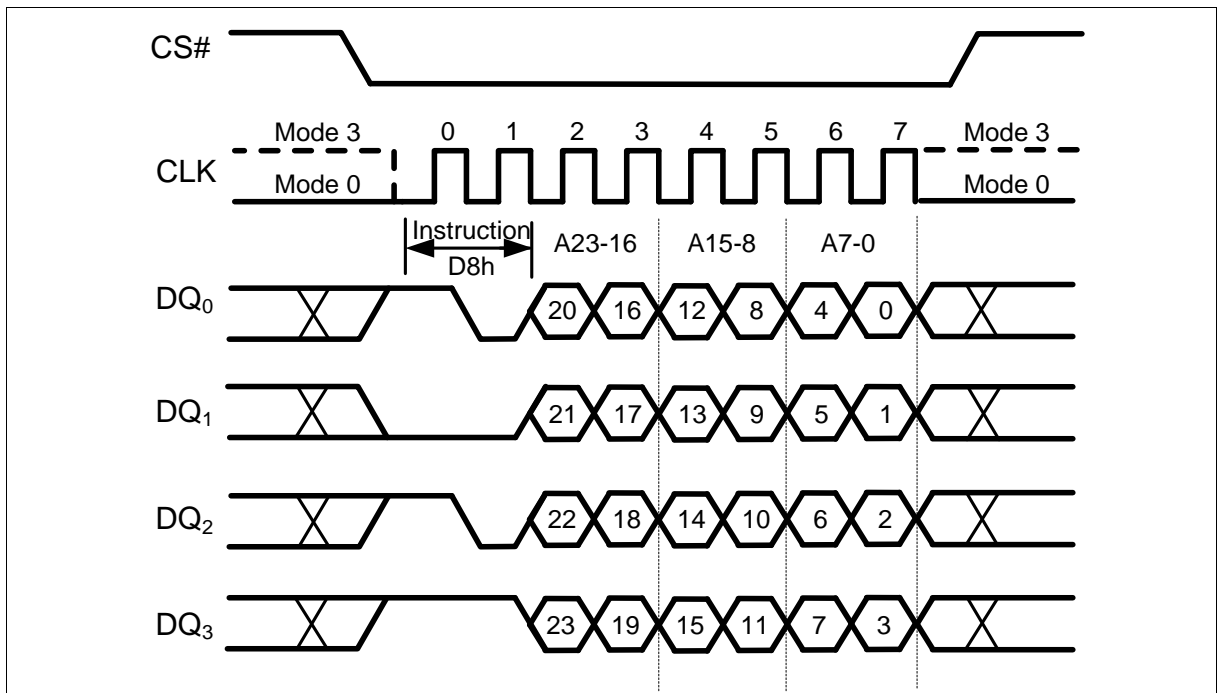

Figure 39 64KB Block Erase Instruction (QPI Mode)

## 11.25. Chip Erase (CE) (C7h / 60h)

The Chip Erase instruction sets all memory within the device to the erased state of all 1s (FFh). A Write Enable instruction must be executed before the device will accept the Chip Erase Instruction (Status Register bit WEL must equal 1). The instruction is initiated by driving the CS# pin low and shifting the instruction code “C7h” or “60h”. The Chip Erase instruction sequence is shown in Figure 40.

The CS# pin must be driven high after the eighth bit has been latched. If this is not done the Chip Erase instruction will not be executed. After CS# is driven high, the self-timed Chip Erase instruction will commence for a time duration of  $t_{CE}$  (See “12.6 AC Electrical Characteristics”). While the Chip Erase cycle is in progress, the Read Status Register instruction may still be accessed to check the status of the WIP bit. The WIP bit is a 1 during the Chip Erase cycle and becomes a 0 when finished and the device is ready to accept other instructions again. After the Chip Erase cycle has finished the Write Enable Latch (WEL) bit in the Status Register is cleared to 0. The Chip Erase instruction will not be executed if any page is protected by the Block Protect (CMP, SEC, TB, BP2, BP1, and BP0) bits.

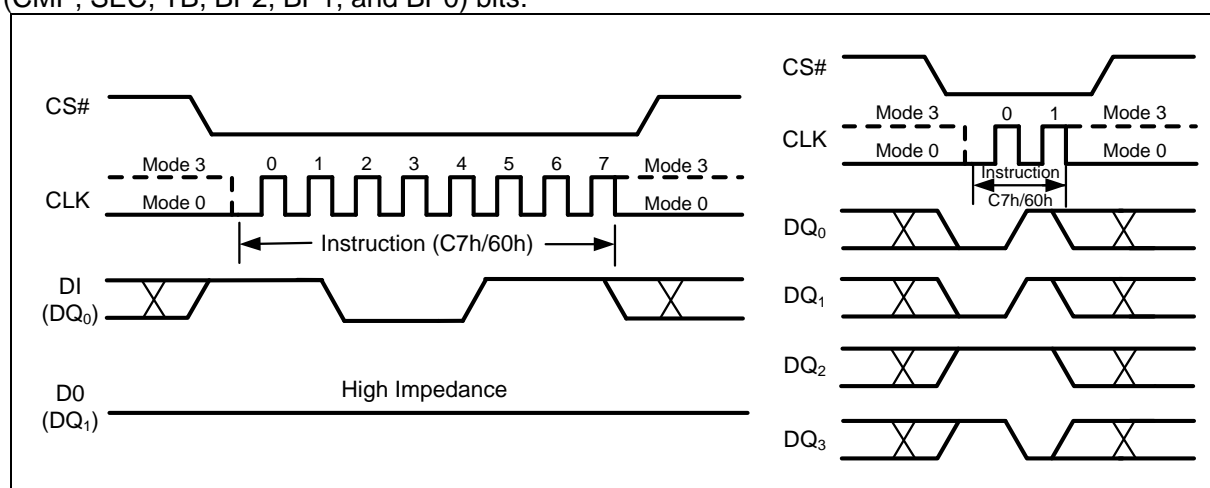

Figure 40 Chip Erase Instruction for SPI Mode (left) or QPI Mode (right)

## 11.26. Erase / Program Suspend (75h)

The Erase/Program Suspend instruction “75h”, allows the system to interrupt a Sector or Block Erase operation or a Page Program operation and then read from any other sectors or blocks. The Erase/Program Suspend instruction sequence is shown in Figure 41 & Figure 42.

The Write Status Register instruction (01h), and Erase/Program Security Registers instructions (44h, 42h), and Erase instructions (20h, 52h, D8h, C7h, 60h), and Page Program instructions (02h, 32h) are not allowed during Erase/Program Suspend. Erase/Program Suspend is valid only during the Sector/Block erase or page program operation. A maximum of time of “ $t_{sus}$ ” (See “12.6 AC Electrical Characteristics”) is required to suspend the erase or program operation.

The Erase/Program Suspend instruction “75h” will be accepted by the device only if the SUS bit in the Status Register equal to 0 and the WIP bit equals to 1 while a Sector or Block Erase or a Page Program operation is on-going. If the SUS bit equal to 1, or the WIP bit equals to 0, the Suspend instruction will be ignored by the device. The WIP bit in the Status Register will be cleared from 1 to 0 within “ $t_{sus}$ ” and the SUS bit in the Status Register will be set from 0 to 1 immediately after Erase/Program Suspend. For a previously resumed Erase/Program operation, it is also required that the Suspend instruction “75h” is not issued earlier than a minimum of time of “ $t_{sus}$ ” following the preceding Resume instruction “7Ah”.

Unexpected power off during the Erase/Program suspend state will reset the device and release the suspend state. SUS bit in the Status Register will also reset to 0. The data within the page, sector or block that was being suspended may become corrupted. It is recommended for the user to implement system design techniques against the accidental power interruption and preserve data integrity during erase/program suspend state.

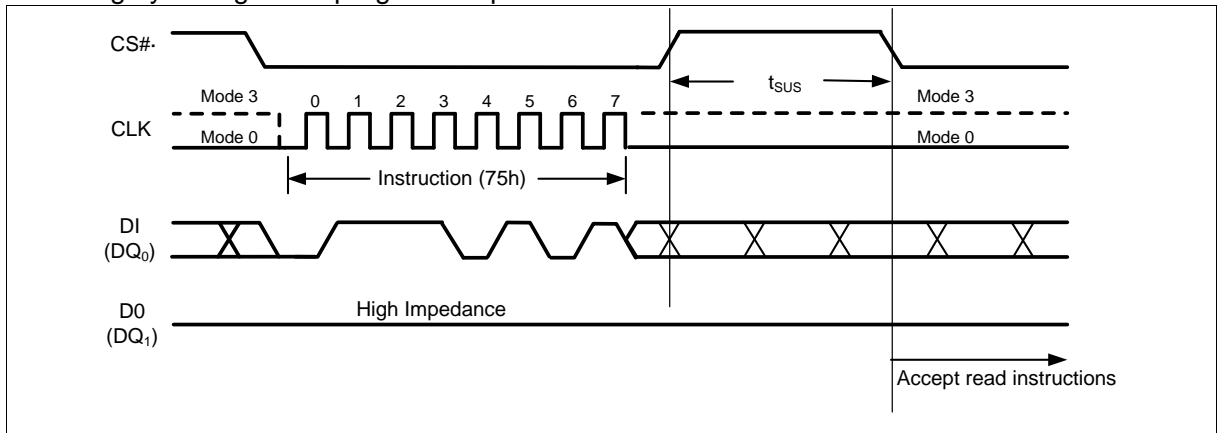

Figure 41 Erase/Program Suspend Instruction (SPI Mode)

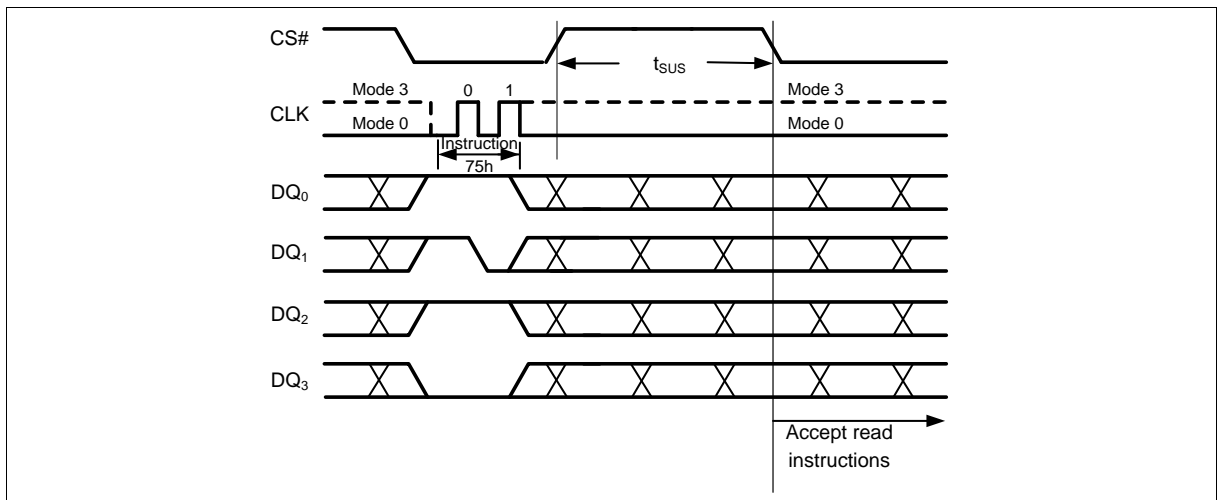

Figure 42 Erase/Program Suspend Instruction (QPI Mode)

## 11.27. Erase / Program Resume (7Ah)

The Erase/Program Resume instruction “7Ah” must be written to resume the Sector or Block Erase operation or the Page Program operation after an Erase/Program Suspend. The Resume instruction “7Ah” will be accepted by the device only if the SUS bit in the Status Register equals to 1 and the WIP bit equals to 0. After issued the SUS bit will be cleared from 1 to 0 immediately, the WIP bit will be set from 0 to 1 within 200ns and the Sector or Block will complete the erase operation or the page will complete the program operation. If the SUS bit equal to 0 or the WIP bit equals to 1, the Resume instruction “7Ah” will be ignored by the device. The Erase/Program Resume instruction sequence is shown in Figure 43 & Figure 44.

Resume instruction is ignored if the previous Erase/Program Suspend operation was interrupted by unexpected power off. It is also required that a subsequent Erase/Program Suspend instruction not to be issued within a minimum of time of “ $t_{SUS}$ ” following a previous Resume instruction.

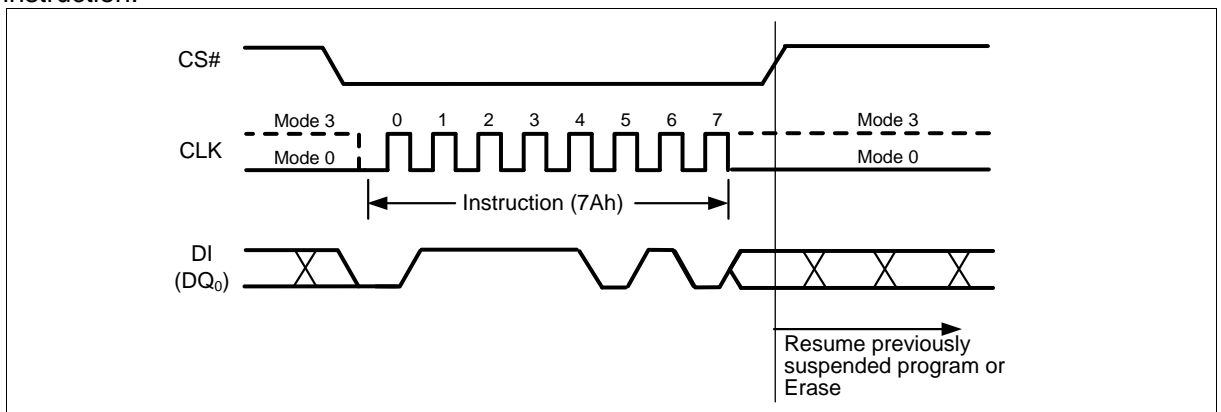

Figure 43 Erase/Program Resume Instruction (SPI Mode)

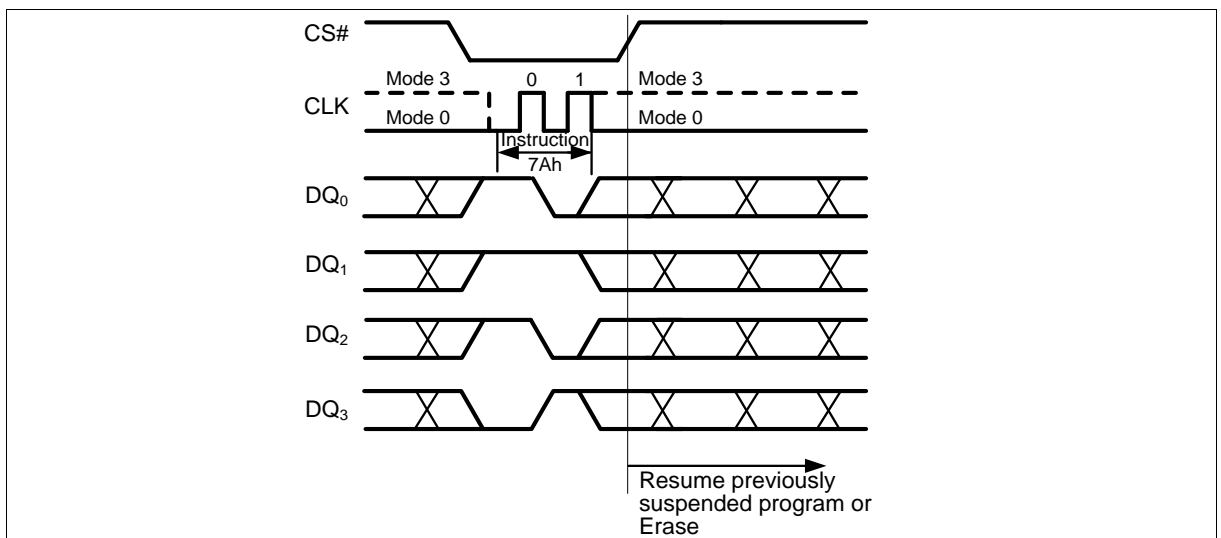

Figure 44 Erase/Program Resume Instruction (QPI Mode)

## 11.28. Power-down (B9h)

Although the standby current during normal operation is relatively low, standby current can be further reduced with the Power-down instruction. The lower power consumption makes the Power-down instruction especially useful for battery powered applications (See  $I_{CC1}$  and  $I_{CC2}$  in “12.4 DC Electrical Characteristics”). The instruction is initiated by driving the CS# pin low and shifting the instruction code “B9h” as shown in Figure 45 & Figure 46.

The CS# pin must be driven high after the eighth bit has been latched. If this is not done the Power-down instruction will not be executed. After CS# is driven high, the power-down state will enter within the time duration of  $t_{DP}$  (See “12.6 AC Electrical Characteristics”). While in the power-down state only the Release from Power-down / Device ID instruction, which restores the device to normal operation, will be recognized. All other instructions are ignored. This includes the Read Status Register instruction, which is always available during normal operation. Ignoring all but one instruction makes the Power Down state a useful condition for securing maximum write protection. The device always powers-up in the normal operation with the standby current of  $I_{CC1}$ .

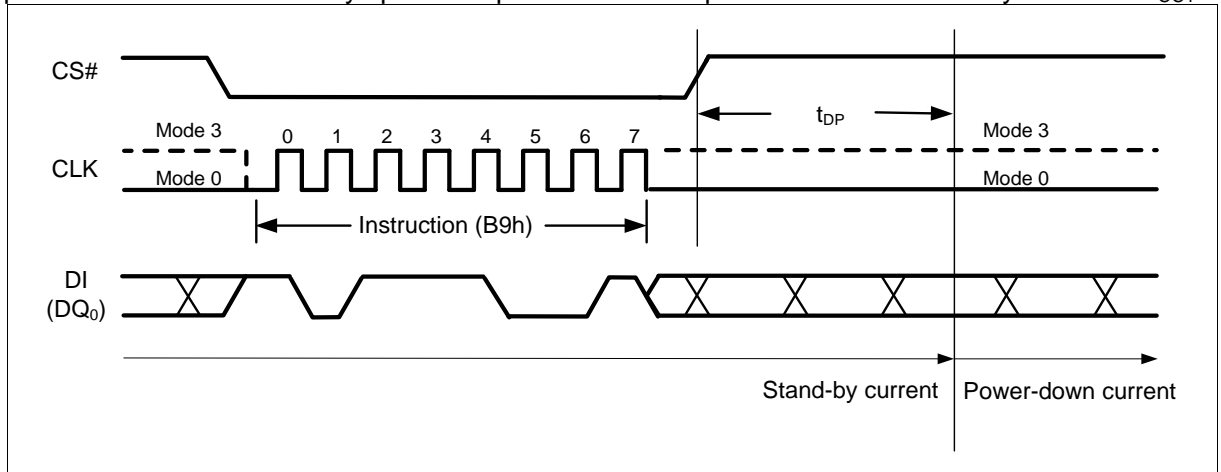

Figure 45 Deep Power-down Instruction (SPI Mode)

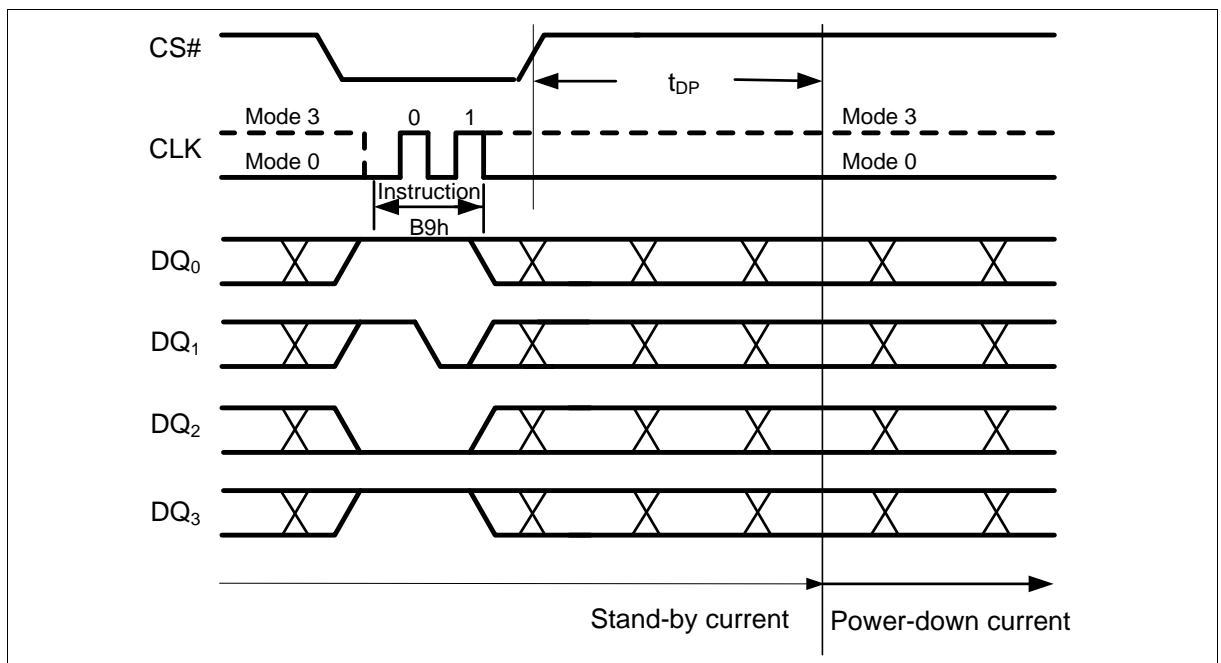

Figure 46 Deep Power-down Instruction (QPI Mode)

## 11.29. Release Power-down / Device ID (ABh)

The Release from Power-down / Device ID instruction is a multi-purpose instruction. It can be used to release the device from the power-down state, or obtain the device's electronic identification (ID) number.

To release the device from the power-down state, the instruction is issued by driving the CS# pin

low, shifting the instruction code “ABh” and driving CS# high as shown in Figure 47 & Figure 48. Release from power-down will take the time duration of  $t_{RES1}$  (See “12.6 AC Electrical Characteristics”) before the device will resume normal operation and other instructions are accepted. The CS# pin must remain high during the  $t_{RES1}$  time duration.

When used only to obtain the Device ID while not in the power-down state, the instruction is initiated by driving the CS# pin low and shifting the instruction code “ABh” followed by 3-dummy bytes. The Device ID bits are then shifted out on the falling edge of CLK with most significant bit (MSB) first as shown in Figure 47 & Figure 48. The Device ID value for the FM25Q64 is listed in Table Manufacturer and Device Identification table. The Device ID can be read continuously. The instruction is completed by driving CS# high.

When used to release the device from the power-down state and obtain the Device ID, the instruction is the same as previously described, and shown in Figure 49 & Figure 50, except that after CS# is driven high it must remain high for a time duration of  $t_{RES2}$  (See “12.6 AC Electrical Characteristics”). After this time duration the device will resume normal operation and other instructions will be accepted. If the Release from Power-down / Device ID instruction is issued while an Erase, Program or Write cycle is in process (when WIP equals 1) the instruction is ignored and will not have any effect on the current cycle.

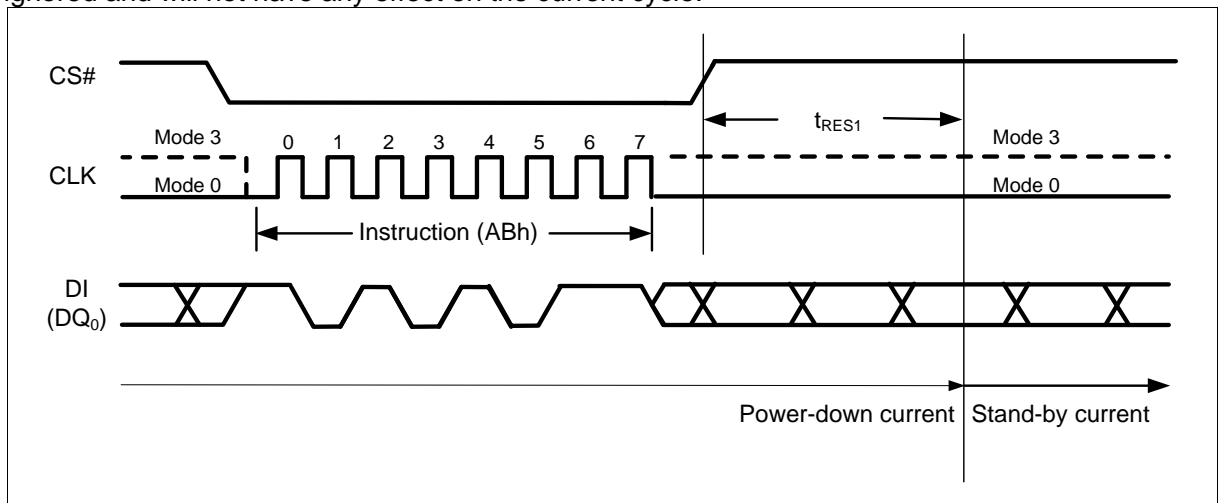

Figure 47 Release Power-down Instruction (SPI Mode)

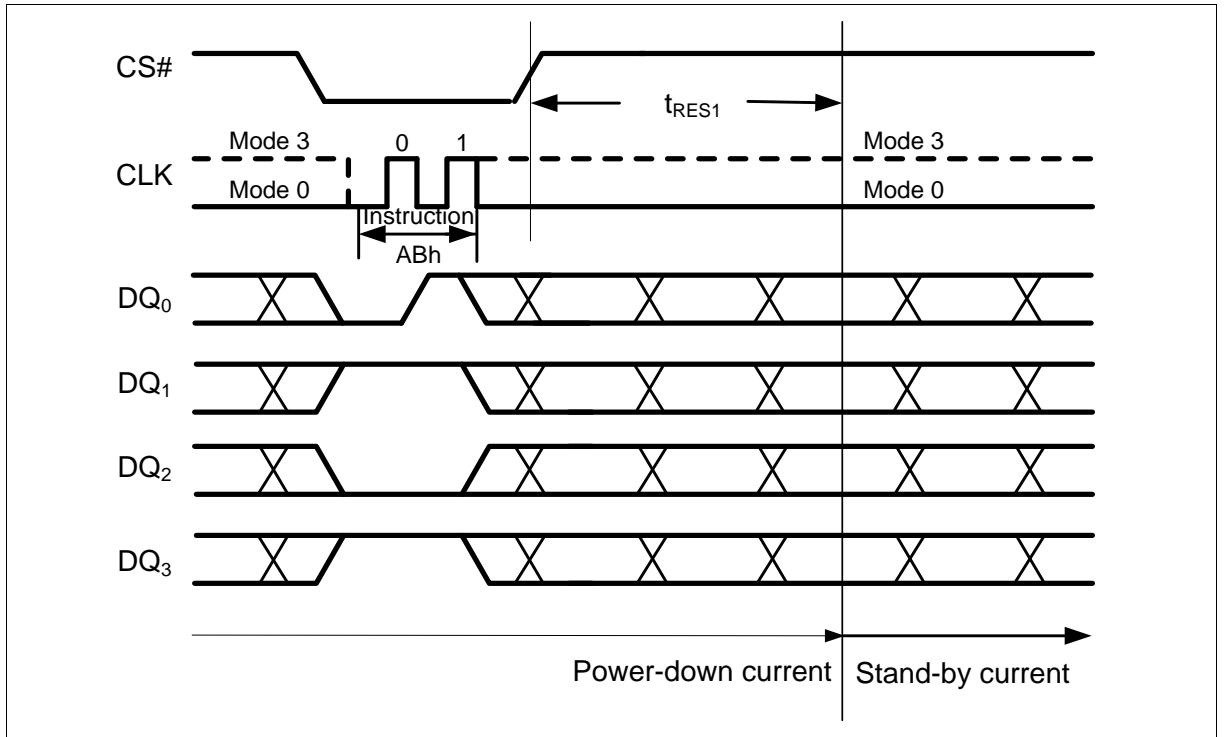

Figure 48 Release Power-down Instruction (QPI Mode)

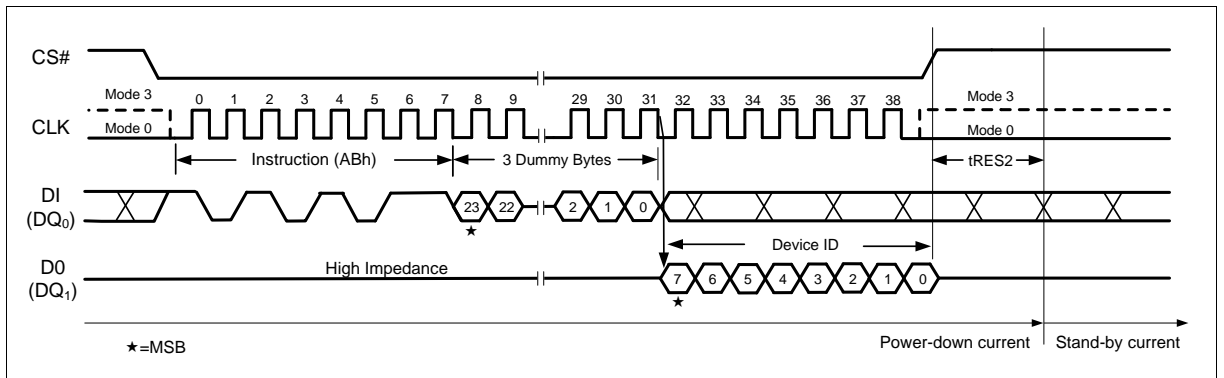

Figure 49 Release Power-down / Device ID Instruction (SPI Mode)

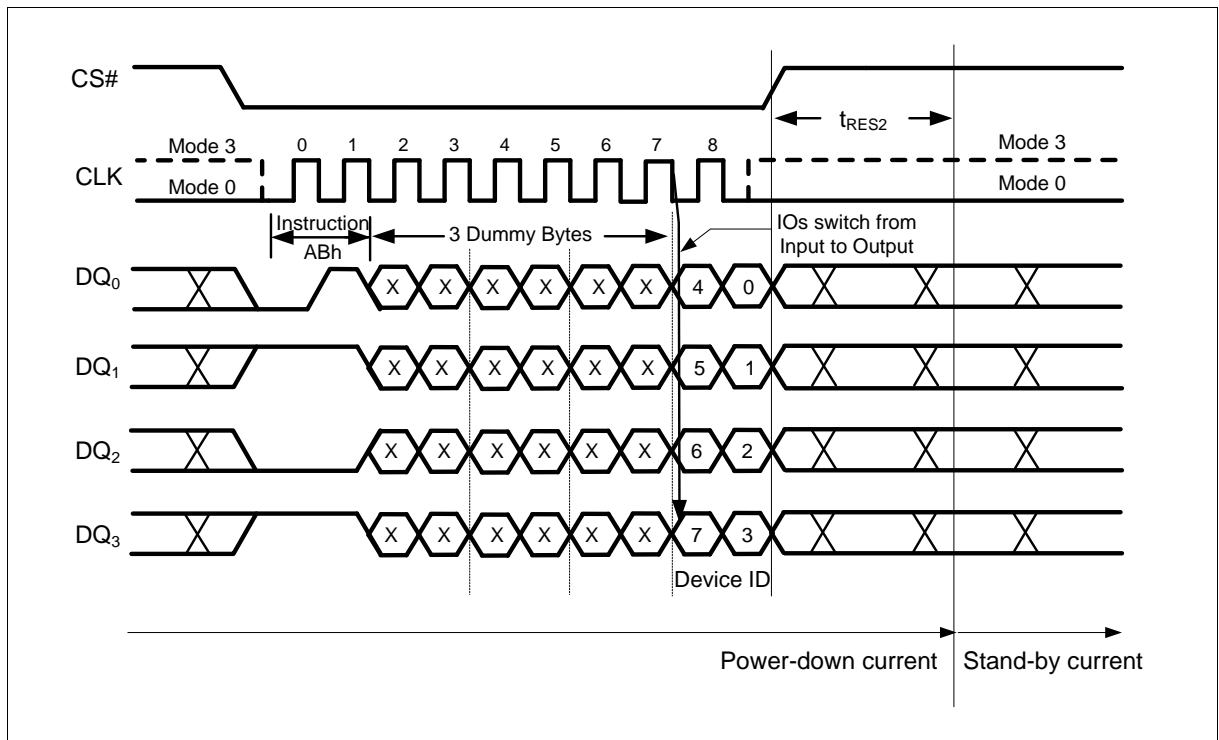

Figure 50 Release Power-down / Device ID Instruction (QPI Mode)

### 11.30. Read Manufacturer / Device ID (90h)

The Read Manufacturer/Device ID instruction is an alternative to the Release from Power-down / Device ID instruction that provides both the JEDEC assigned manufacturer ID and the specific device ID.

The Read Manufacturer/Device ID instruction is very similar to the Release from Power-down / Device ID instruction. The instruction is initiated by driving the CS# pin low and shifting the instruction code "90h" followed by a 24-bit address A23-A0 of 000000h. After which, the Manufacturer ID for Shanghai Fudan Microelectronics Group Co., Ltd (A1h) and the Device ID are shifted out on the falling edge of CLK with most significant bit (MSB) first as shown in Figure 51 & Figure 52. The Device ID value for the FM25Q64 is listed in Table Manufacturer and Device Identification table. If the 24-bit address is initially set to 000001h the Device ID will be read first and then followed by the Manufacturer ID. The Manufacturer and Device IDs can be read continuously, alternating from one to the other. The instruction is completed by driving CS# high.

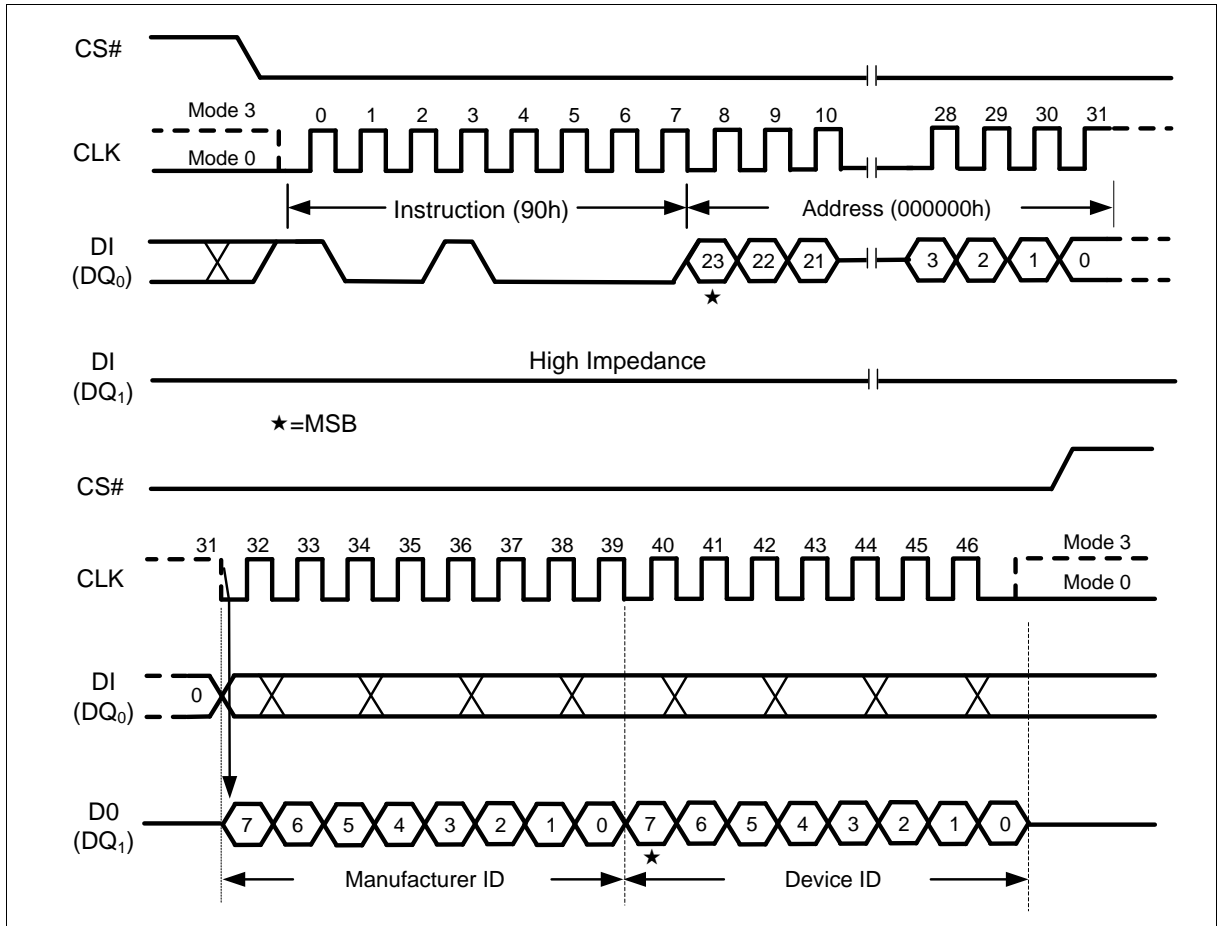

Figure 51 Read Manufacturer / Device ID Instruction (SPI Mode)

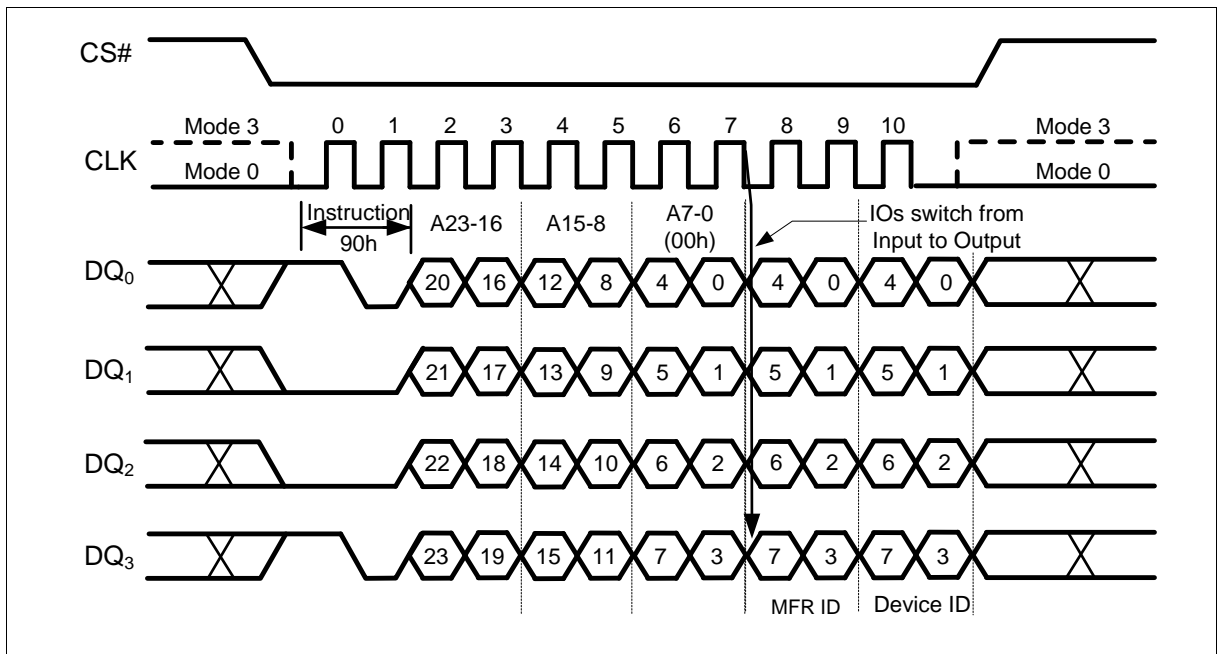

Figure 52 Read Manufacturer / Device ID Instruction (QPI Mode)

## 11.31. Read Manufacturer / Device ID Dual I/O (92h)

The Read Manufacturer / Device ID Dual I/O instruction is an alternative to the Read Manufacturer / Device ID instruction that provides both the JEDEC assigned manufacturer ID and the specific device ID at 2x speed.

The Read Manufacturer / Device ID Dual I/O instruction is similar to the Fast Read Dual I/O instruction. The instruction is initiated by driving the CS# pin low and shifting the instruction code “92h” followed by a 24-bit address A23-A0 of 000000h, 8-bit Continuous Read Mode Bits, with the capability to input the Address bits two bits per clock. After which, the Manufacturer ID for Shanghai Fudan Microelectronics Group Co., Ltd (A1h) and the Device ID are shifted out 2 bits per clock on the falling edge of CLK with most significant bits (MSB) first as shown in Figure 53. The Device ID value for the FM25Q64 is listed in Table Manufacturer and Device Identification table. If the 24-bit address is initially set to 000001h the Device ID will be read first and then followed by the Manufacturer ID. The Manufacturer and Device IDs can be read continuously, alternating from one to the other. The instruction is completed by driving CS# high.

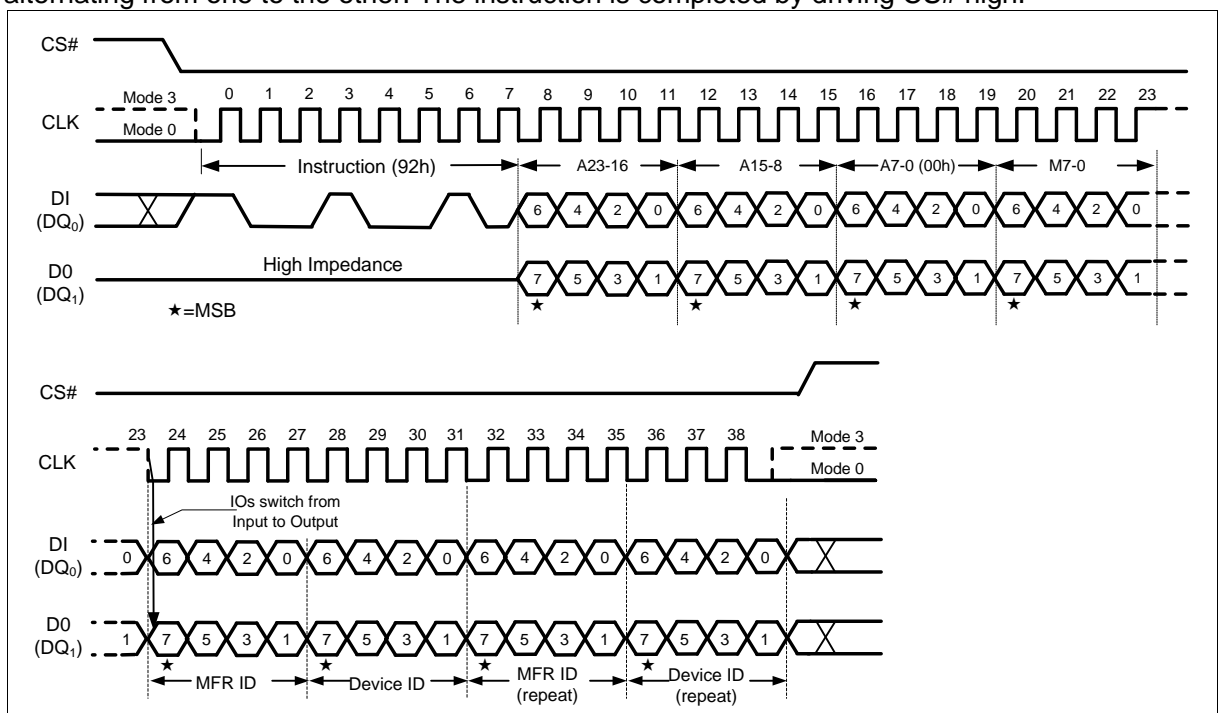

Figure 53 Read Manufacturer / Device ID Dual I/O Instruction (SPI Mode only)

**Note:**

The “Continuous Read Mode” bits M7-M0 must be set to Fxh to be compatible with Fast Read Dual I/O instruction.

## 11.32. Read Manufacturer / Device ID Quad I/O (94h)

The Read Manufacturer / Device ID Quad I/O instruction is an alternative to the Read Manufacturer / Device ID instruction that provides both the JEDEC assigned manufacturer ID and the specific device ID at 4x speed.

The Read Manufacturer / Device ID Quad I/O instruction is similar to the Fast Read Quad I/O instruction. The instruction is initiated by driving the CS# pin low and shifting the instruction code “94h” followed by a 24-bit address A23-A0 of 000000h, 8-bit Continuous Read Mode Bits and then four clock dummy cycles, with the capability to input the Address bits four bits per clock. After which, the Manufacturer ID for Shanghai Fudan Microelectronics Group Co., Ltd (A1h) and the Device ID are shifted out four bits per clock on the falling edge of CLK with most significant bit

(MSB) first as shown in Figure 54. The Device ID value for the FM25Q64 is listed in Manufacturer and Device Identification table. If the 24-bit address is initially set to 000001h the Device ID will be read first and then followed by the Manufacturer ID. The Manufacturer and Device IDs can be read continuously, alternating from one to the other. The instruction is completed by driving CS# high.

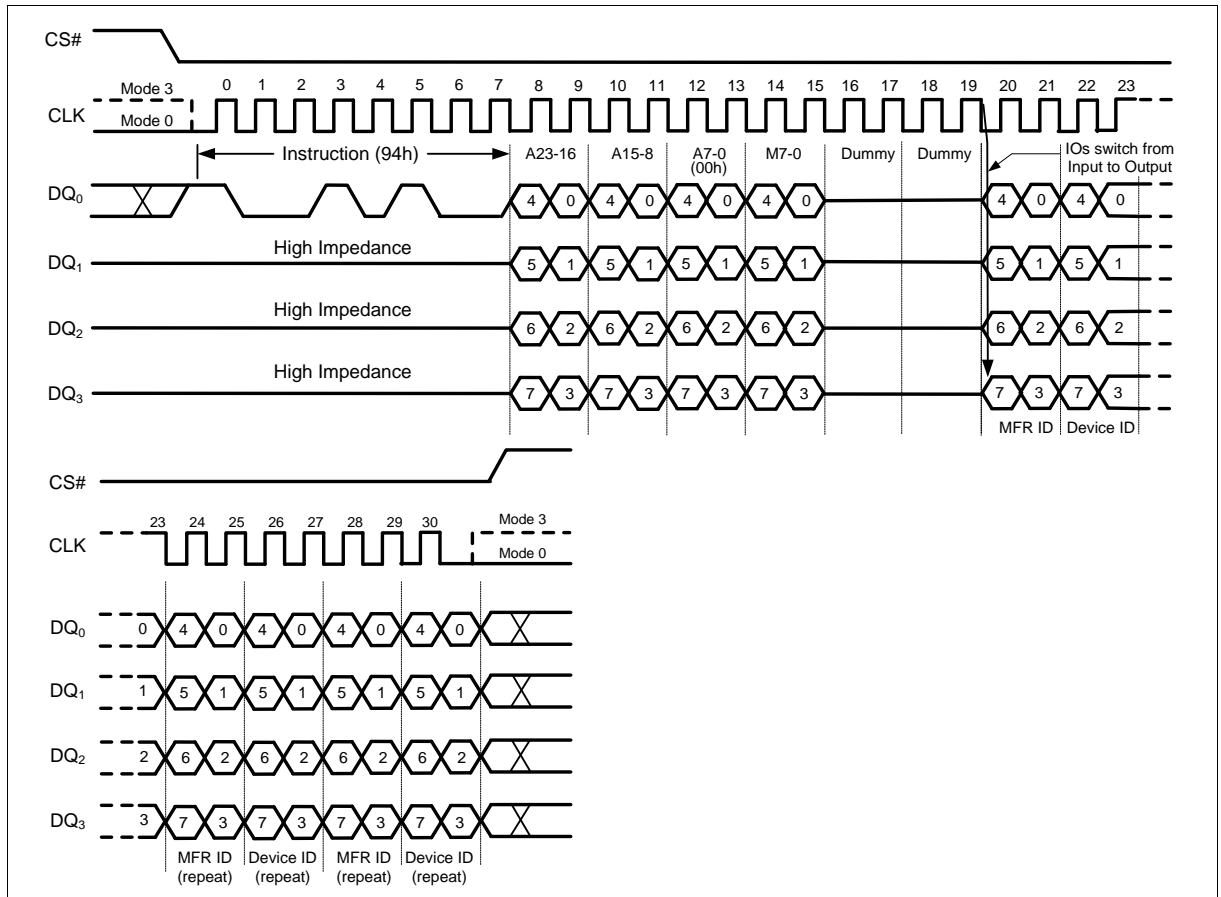

Figure 54 Read Manufacturer / Device ID Quad I/O Instruction (SPI Mode only)

**Note:**

The “Continuous Read Mode” bits M7-M0 must be set to Fxh to be compatible with Fast Read Quad I/O instruction.

### 11.33. Read Unique ID Number (4Bh)

The Read Unique ID Number instruction accesses a factory-set read-only 64-bit number that is unique to each FM25Q64 device. The ID number can be used in conjunction with user software methods to help prevent copying or cloning of a system. The Read Unique ID instruction is initiated by driving the CS# pin low and shifting the instruction code “4Bh” followed by a four bytes of dummy clocks. After which, the 64-bit ID is shifted out on the falling edge of CLK as shown in Figure 55.

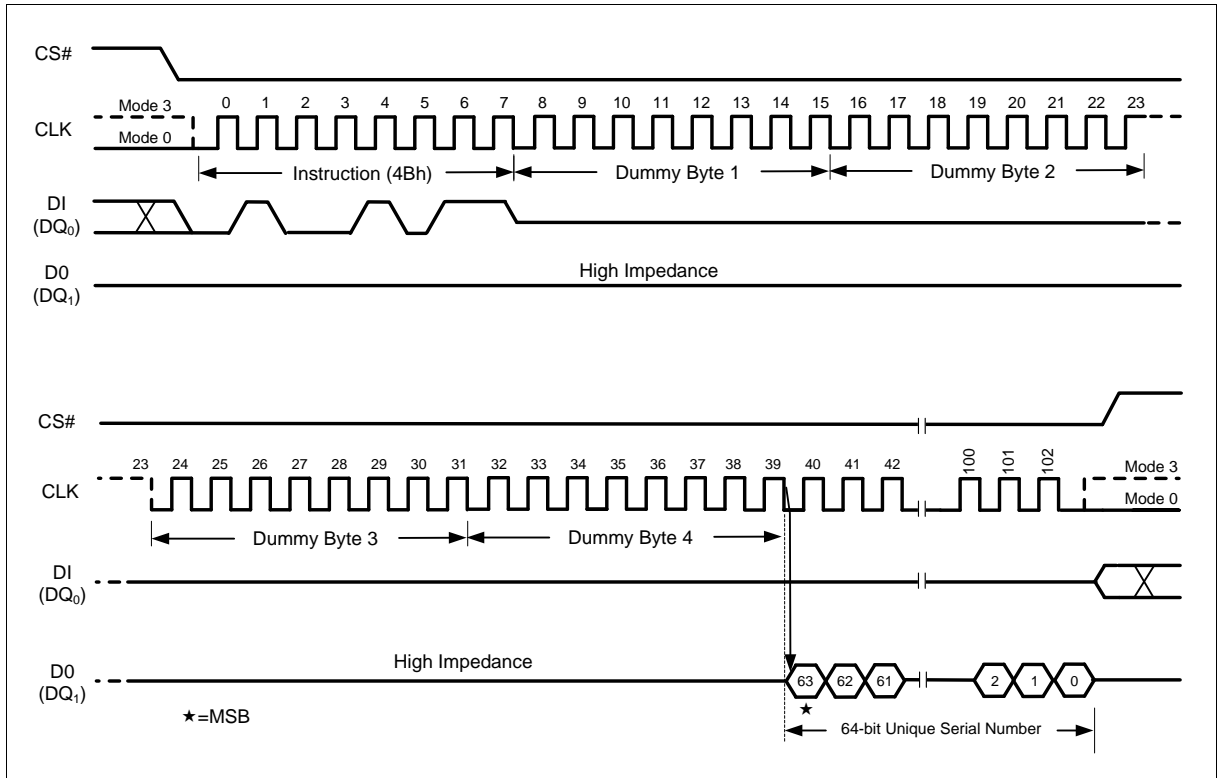

Figure 55 Read Unique ID Number Instruction (SPI Mode only)

### 11.34. Read JEDEC ID (9Fh)

For compatibility reasons, the FM25Q64 provides several instructions to electronically determine the identity of the device. The Read JEDEC ID instruction is compatible with the JEDEC standard for SPI compatible serial memories. The instruction is initiated by driving the CS# pin low and shifting the instruction code “9Fh”. The JEDEC assigned Manufacturer ID byte for Shanghai Fudan Microelectronics Group Co., Ltd (A1h) and two Device ID bytes, Memory Type (ID15-ID8) and Capacity ID7-ID0 are then shifted out on the falling edge of CLK with most significant bit (MSB) first as shown in Figure 56 & Figure 57. For memory type and capacity values refer to Table Manufacturer and Device Identification table.

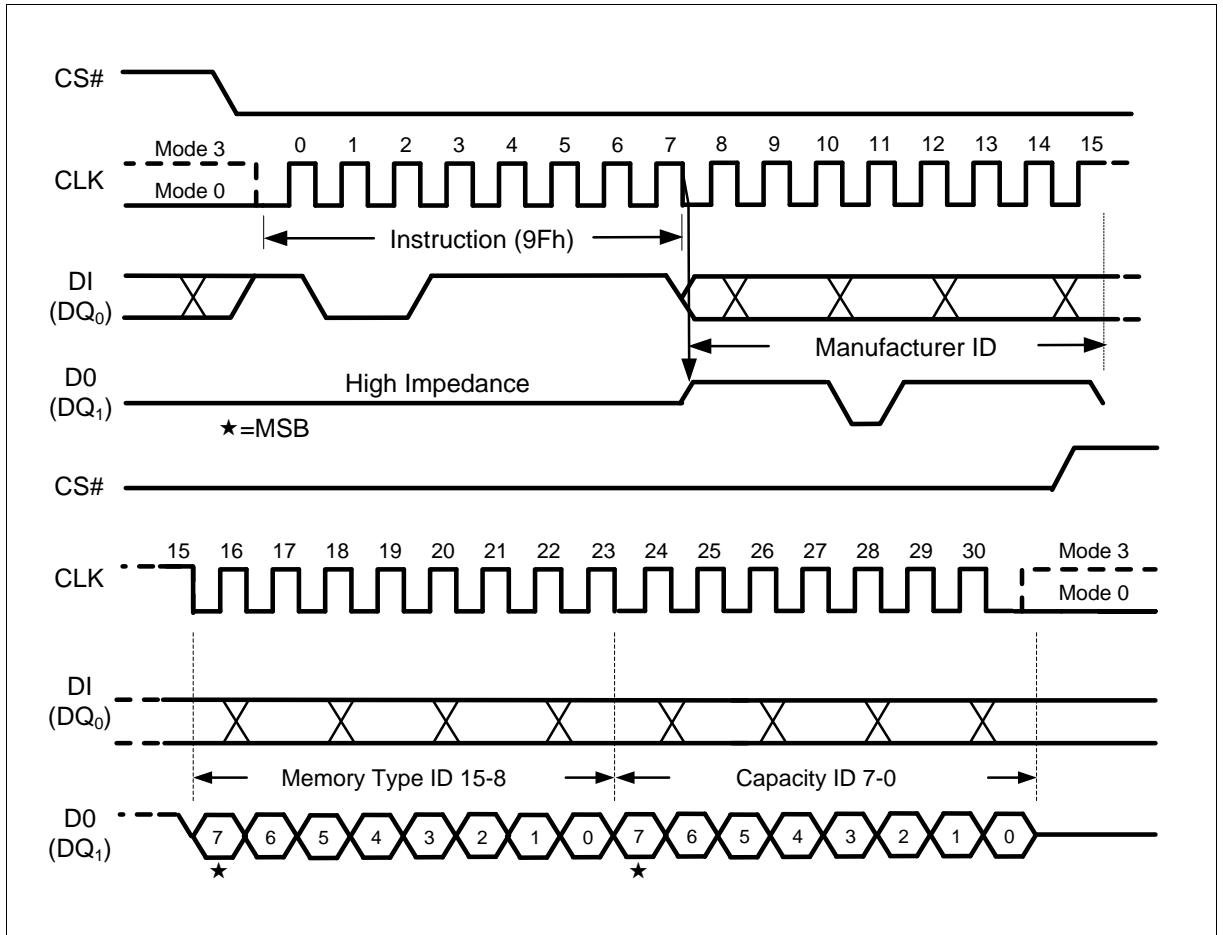

Figure 56 Read JEDEC ID Instruction (SPI Mode)

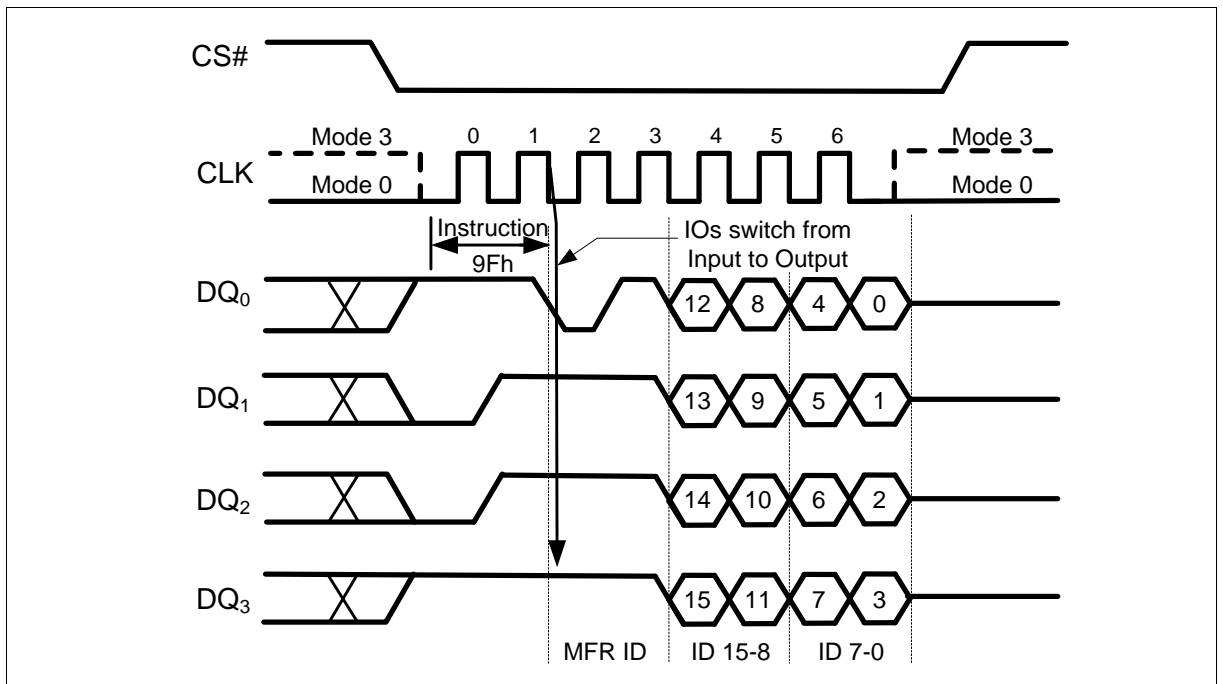

Figure 57 Read JEDEC ID Instruction (QPI Mode)

## 11.35. Read SFDP Register (5Ah)

The FM25Q64 features a 256-Byte Serial Flash Discoverable Parameter (SFDP) register that contains information about device configurations, available instructions and other features. The SFDP parameters are stored in one or more Parameter Identification (PID) tables. Currently only one PID table is specified, but more may be added in the future. The Read SFDP Register instruction is compatible with the SFDP standard initially established in 2010 for PC and other applications, as well as the JEDEC standard 1.0 that is published in 2011.

The Read SFDP instruction is initiated by driving the /CS pin low and shifting the instruction code “5Ah” followed by a 24-bit address (A23-A0)<sup>(1)</sup> into the DI pin. Eight “dummy” clocks are also required before the SFDP register contents are shifted out on the falling edge of the 40th CLK with most significant bit (MSB) first as shown in Figure 58.

For SFDP register values and descriptions, refer to the following SFDP Definition table.

Note: 1. A23-A8 = 0; A7-A0 are used to define the starting byte address for the 256-Byte SFDP Register.

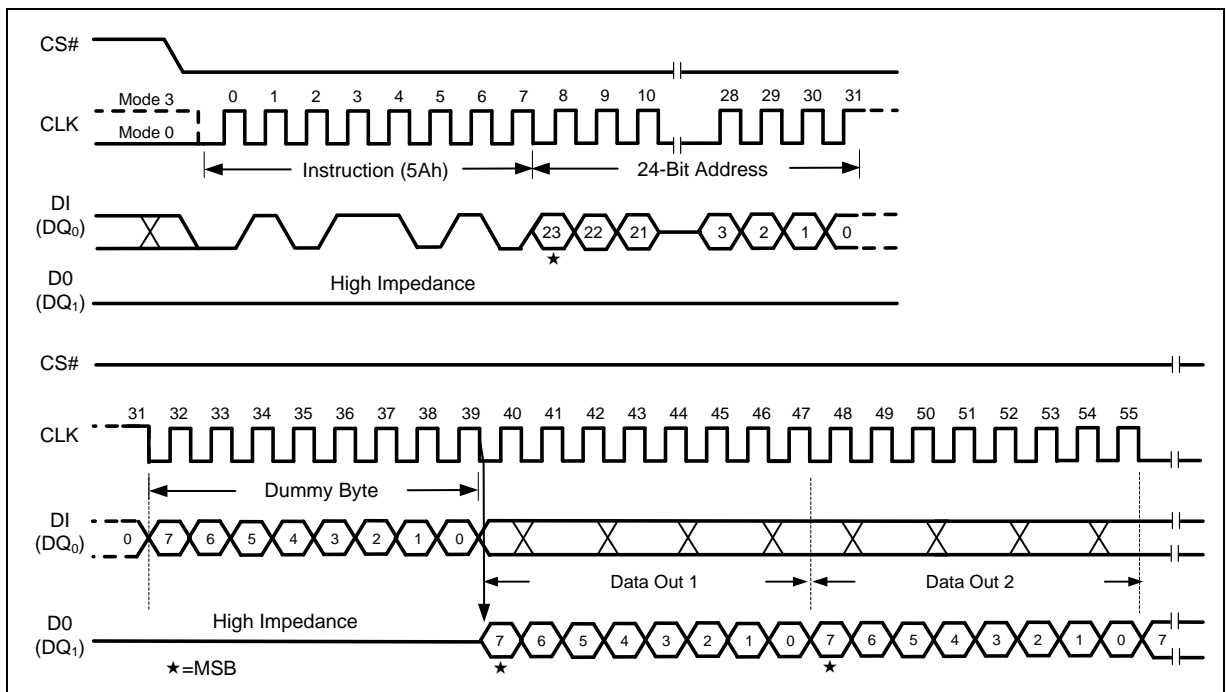

Figure 58 Read SFDP Register Instruction

Serial Flash Discoverable Parameter (JEDEC Revision 1.0) Definition Table

BYTE ADDRESS	DATA	DESCRIPTION	COMMENT
00h	53h	SFDP Signature	SFDP Signature = 50444653h
01h	46h	SFDP Signature	
02h	44h	SFDP Signature	
03h	50h	SFDP Signature	
04h	00h	SFDP Minor Revision Number	JEDEC Revision 1.0
05h	01h	SFDP Major Revision Number	
06h	00h	Number of Parameter Headers (NPH)	1 Parameter Header
07h	FFh	Reserved	
08h	00h	PID <sup>(3)</sup> (0): ID Number	00h = JEDEC specified
09h	00h	PID(0): Parameter Table Minor Revision Number	JEDEC Revision 1.0

BYTE ADDRESS	DATA	DESCRIPTION	COMMENT
0Ah	01h	PID(0): Parameter Table Major Revision Number	
0Bh	09h	PID(0): Parameter Table Length	9 Dwords <sup>(2)</sup>
0Ch	80h	PID(0): Parameter Table Pointer (PTP) (A7-A0)	PID(0) Pointer = 000080h
0Dh	00h	PID(0): Parameter Table Pointer (PTP) (A15-A8)	
0Eh	00h	PID(0): Parameter Table Pointer (PTP) (A23-A16)	
0Fh	FFh	Reserved	
10h	FFh	Reserved	
... <sup>(1)</sup>	FFh	Reserved	
7Fh	FFh	Reserved	
80h	E5h	Bit[7:5]=111 Reserved Bit[4:3]=00 Non-volatile Status Register Bit[2]=1 Page Programmable Bit[1:0]=01 Supports 4KB Erase	
81h	20h	4K-Byte Erase Opcode	
82h	F1h	Bit[7] =1 Reserved Bit[6] =1 Supports (1-1-4) Fast Read Bit[5] =1 Supports (1-4-4) Fast Read Bit[4] =1 Supports (1-2-2) Fast Read Bit[3] =0 Not support Dual Transfer Rate Bit[2:1]=00 3-Byte/24-Bit Only Addressing Bit[0] =1 Supports (1-1-2) Fast Read	
83h	FFh	Reserved	
84h	FFh	Flash Size in Bits	64 Mega Bits = 03FFFFFFh
85h	FFh	Flash Size in Bits	
86h	FFh	Flash Size in Bits	
87h	03h	Flash Size in Bits	
88h	44h	Bit[7:5]=010 8 Mode Bits are needed Bit[4:0]=00100 16 Dummy Bits are needed	Fast Read Quad I/O Setting
89h	EBh	Quad Input Quad Output Fast Read Opcode	
8Ah	08h	Bit[7:5]=000 No Mode Bits are needed Bit[4:0]=01000 8 Dummy Bits are needed	Fast Read Quad Output Setting
8Bh	6Bh	Single Input Quad Output Fast Read Opcode	
8Ch	08h	Bit[7:5]=000 No Mode Bits are needed Bit[4:0]=01000 8 Dummy Bits are needed	Fast Read Dual Output Setting
8Dh	3Bh	Single Input Dual Output Fast Read Opcode	
8Eh	80h	Bit[7:5]=100 8 Mode bits are needed Bit[4:0]=00000 No Dummy bits are needed	Fast Read Dual I/O Setting
8Fh	BBh	Dual Input Dual Output Fast Read Opcode	
90h	FEh	Bit[7:5]=111 Reserved Bit[4]=1 support (4-4-4) Fast Read Bit[3:1]=111 Reserved Bit[0]=0 Not support (2-2-2) Fast Read	
91h	FFh	Reserved	
92h	FFh	Reserved	
93h	FFh	Reserved	
94h	FFh	Reserved	
95h	FFh	Reserved	
96h	00h	No Mode Bits or Dummy Bits for (2-2-2) Fast Read	

BYTE ADDRESS	DATA	DESCRIPTION	COMMENT
97h	00h	Not support (2-2-2) Fast Read	
98h	FFh	Reserved	
99h	FFh	Reserved	
9Ah	08h	Bit[7:5]=000 No Mode bits are needed Bit[4:0]=01000 8 Dummy bits are needed	
9Bh	EBh	QPI Fast Read Opcode	
9Ch	0Ch	Sector Type 1 Size (4KB)	Sector Erase Type & Opcode
9Dh	20h	Sector Type 1 Opcode	
9Eh	0Fh	Sector Type 2 Size (32KB)	
9Fh	52h	Sector Type 2 Opcode	
A0h	10h	Sector Type 3 Size (64KB)	Sector Erase Type & Opcode
A1h	D8h	Sector Type 3 Opcode	
A2h	00h	Sector Type 4 Size (256KB) – Not supported	
A3h	00h	Sector Type 4 Opcode – Not supported	
... <sup>(1)</sup>	FFh	Reserved	
FFh	FFh	Reserved	

Notes:

1. Data stored in Byte Address 10h to 7Fh & A4h to FFh are Reserved, the value is FFh.
2. 1 Dword = 4 Bytes
3. PID(x) = Parameter Identification Table (x)

## 11.36. Erase Security Sectors (44h)

The FM25Q64 offers one 1024-byte Security Sector. The Security Sector may be used by the system manufacturers to store security and other important information separately from the main memory array.

The Erase Security Sector instruction is similar to the Sector Erase instruction. A Write Enable instruction must be executed before the device will accept the Erase Security Sector Instruction (Status Register bit WEL must equal 1). The instruction is initiated by driving the CS# pin low and shifting the instruction code “44h” followed by a 24-bit address A23-A0 to erase Security Sectors.

A23-16	A15-10	A9-0
00h	000000	Don't Care

The Erase Security Sector instruction sequence is shown in Figure 59. The CS# pin must be driven high after the eighth bit of the last byte has been latched. If this is not done the instruction will not be executed. After CS# is driven high, the self-timed Erase Security Sector operation will commence for a time duration of  $t_{SE}$  (See “12.6 AC Electrical Characteristics”). While the Erase Security Sector cycle is in progress, the Read Status Register instruction may still be accessed for checking the status of the WIP bit. The WIP bit is a 1 during the erase cycle and becomes a 0 when the cycle is finished and the device is ready to accept other instructions again. After the Erase Security Sector cycle has finished the Write Enable Latch (WEL) bit in the Status Register is cleared to 0. The Security Sector Lock Bit (LB) in the Status Register-2 can be used to OTP protect the Security Sectors. Once the LB bit is set to 1, the Security Sector will be permanently locked, Erase Security Sector instruction will be ignored.

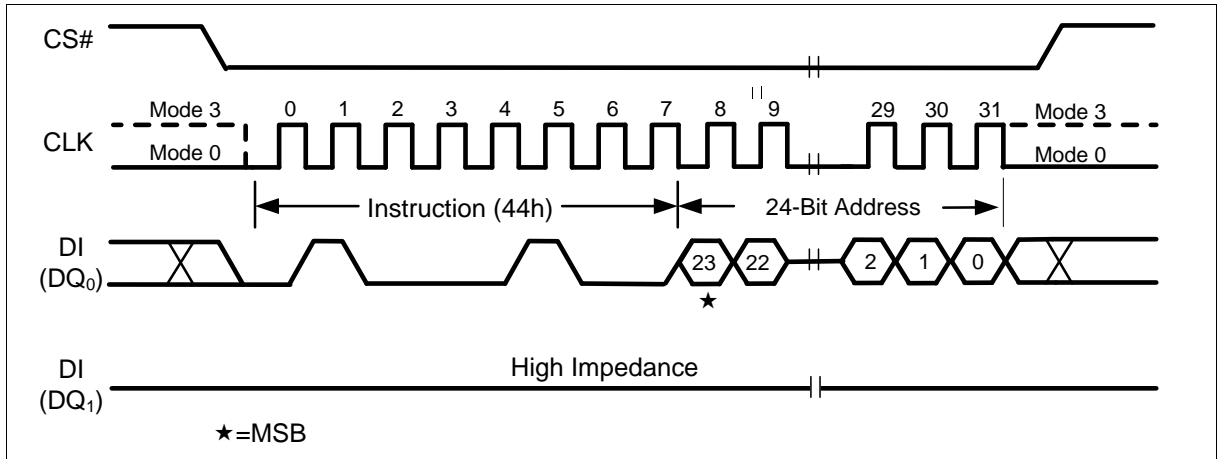

Figure 59 Erase Security Sectors Instruction (SPI Mode only)

## 11.37. Program Security Sectors (42h)

The Program Security Sector instruction is similar to the Page Program instruction. It allows from one byte to 256 bytes of Security Sector data to be programmed at previously erased (FFh) memory locations. A Write Enable instruction must be executed before the device will accept the Program Security Sector Instruction (Status Register bit WEL= 1). The instruction is initiated by driving the CS# pin low then shifting the instruction code “42h” followed by a 24-bit address A23-A0 and at least one data byte, into the DI pin. The CS# pin must be held low for the entire length of the instruction while data is being sent to the device.

A23-16	A15-10	A9-8	A7-0
00h	0 0 0 0	0 0 0 1 1 0 1 1	Byte Address

The Program Security Sector instruction sequence is shown in Figure 60. The Security Sector Lock Bit (LB) in the Status Register-2 can be used to OTP protect the Security Sectors. Once a lock bit is set to 1, the Security Sector will be permanently locked, Program Security Sector instruction will be ignored.

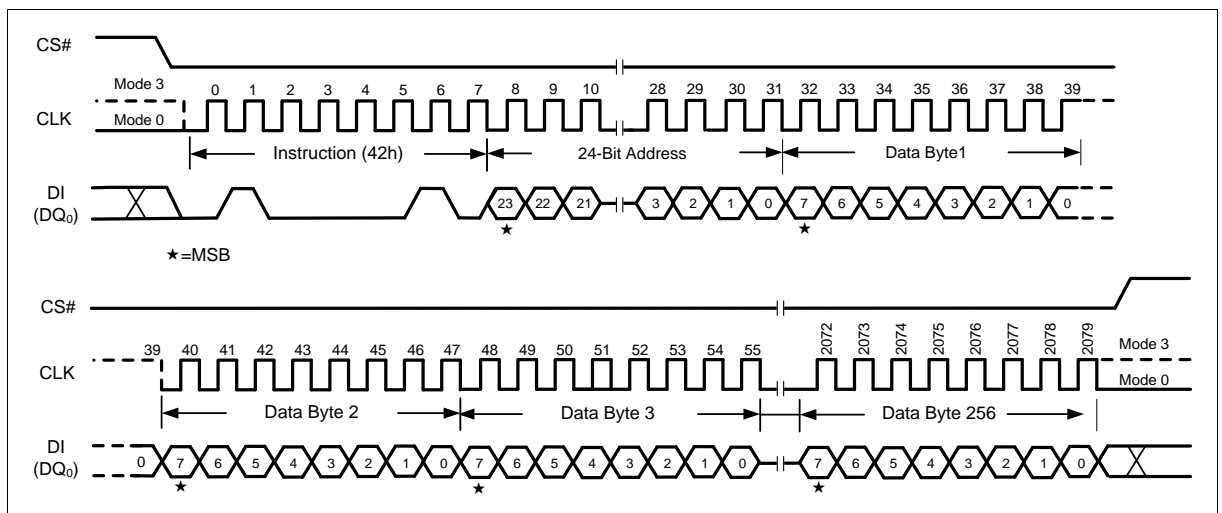

Figure 60 Program Security Sectors Instruction (SPI Mode only)

## 11.38. Read Security Sectors (48h)

The Read Security Sector instruction is similar to the Fast Read instruction and allows one or more data bytes to be sequentially read from one of the two Security Sectors. The instruction is initiated by driving the CS# pin low and then shifting the instruction code “48h” followed by a 24-bit address A23-A0 and eight “dummy” clocks into the DI pin. The code and address bits are latched on the rising edge of the CLK pin. After the address is received, the data byte of the addressed memory location will be shifted out on the DO pin at the falling edge of CLK with most significant bit (MSB) first. The byte address is automatically incremented to the next byte address after each byte of data is shifted out. Once the byte address reaches the last byte of the register (byte 3FFh), it will be reset to 00h, the first byte of the register, and continue to increment. The instruction is completed by driving CS# high. The Read Security Sector instruction sequence is shown in Figure 61. If a Read Security Sector instruction is issued while an Erase, Program or Write cycle is in process (WIP =1) the instruction is ignored and will not have any effect on the current cycle. The Read Security Sector instruction allows clock rates from D.C. to a maximum of FR (see “12.6 AC Electrical Characteristics”).

A23-16	A15-10	A9-8	A7-0
00h	0 0 0 0	0 0 0 1 1 0 1 1	Byte Address

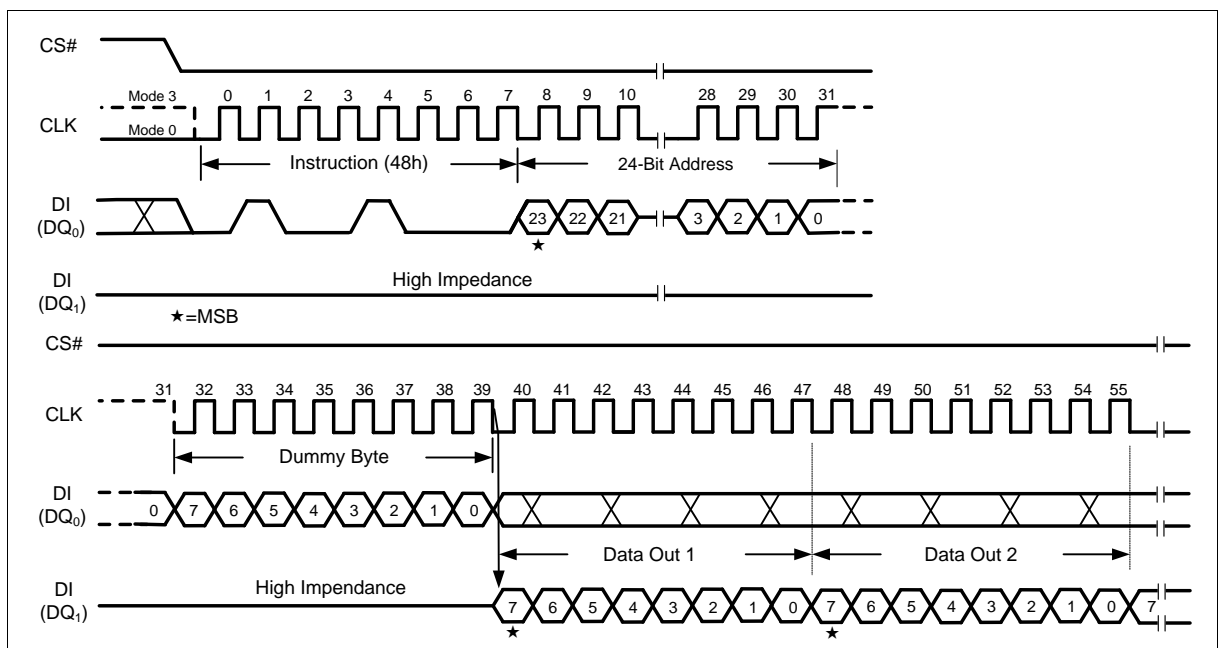

Figure 61 Read Security Sectors Instruction (SPI Mode only)

## 11.39. Set Read Parameters (C0h)

In QPI mode, to accommodate a wide range of applications with different needs for either maximum read frequency or minimum data access latency, “Set Read Parameters (C0h)” instruction can be used to configure the number of dummy clocks for “Fast Read (0Bh)”, “Fast Read Quad I/O (EBh)” & “Burst Read with Wrap (0Ch)” instructions, and to configure the number of bytes of “Wrap Length” for the “Burst Read with Wrap (0Ch)” instruction.

In Standard SPI mode, the “Set Read Parameters (C0h)” instruction is not accepted. The dummy clocks for various Fast Read instructions in Standard/Dual/Quad SPI mode are fixed, please refer to Table 4~Table 7 the Instruction set for details. The “Wrap Length” is set by W5-4 bit in the “Set Burst with Wrap (77h)” instruction. This setting will remain unchanged when the device is switched from Standard SPI mode to QPI mode.

The default “Wrap Length” after a power up or a Reset instruction is 8 bytes, the default number of dummy clocks is 2.

P5 – P4	DUMMY CLOCKS	MAXIMUM READ FREQ.
0 0	2	50MHz
0 1	4	80MHz
1 0	6	104MHz
1 1	8	104MHz

P1 – P0	WRAP LENGTH
0 0	8-byte
0 1	16-byte
1 0	32-byte
1 1	64-byte

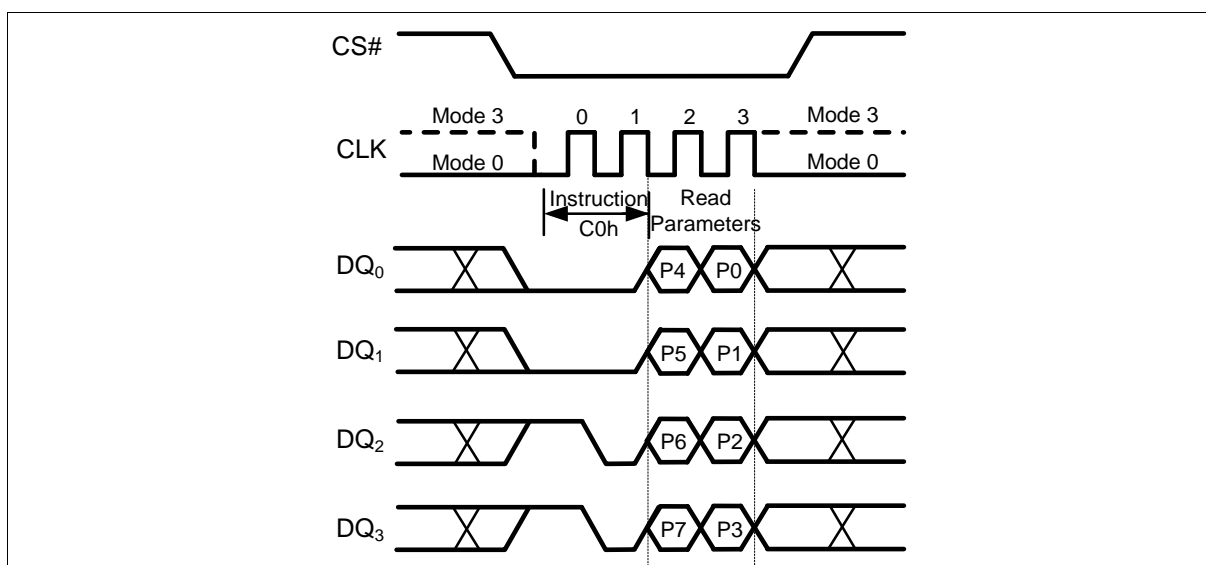

Figure 62 Set Read Parameters Instruction (QPI Mode only)

## 11.40. Burst Read with Wrap (0Ch)

The “Burst Read with Wrap (0Ch)” instruction provides an alternative way to perform the read operation with “Wrap Around” in QPI mode. The instruction is similar to the “Fast Read (0Bh)” instruction in QPI mode, except the addressing of the read operation will “Wrap Around” to the beginning boundary of the “Wrap Length” once the ending boundary is reached.

The “Wrap Length” and the number of dummy clocks can be configured by the “Set Read Parameters C0h)” instruction.

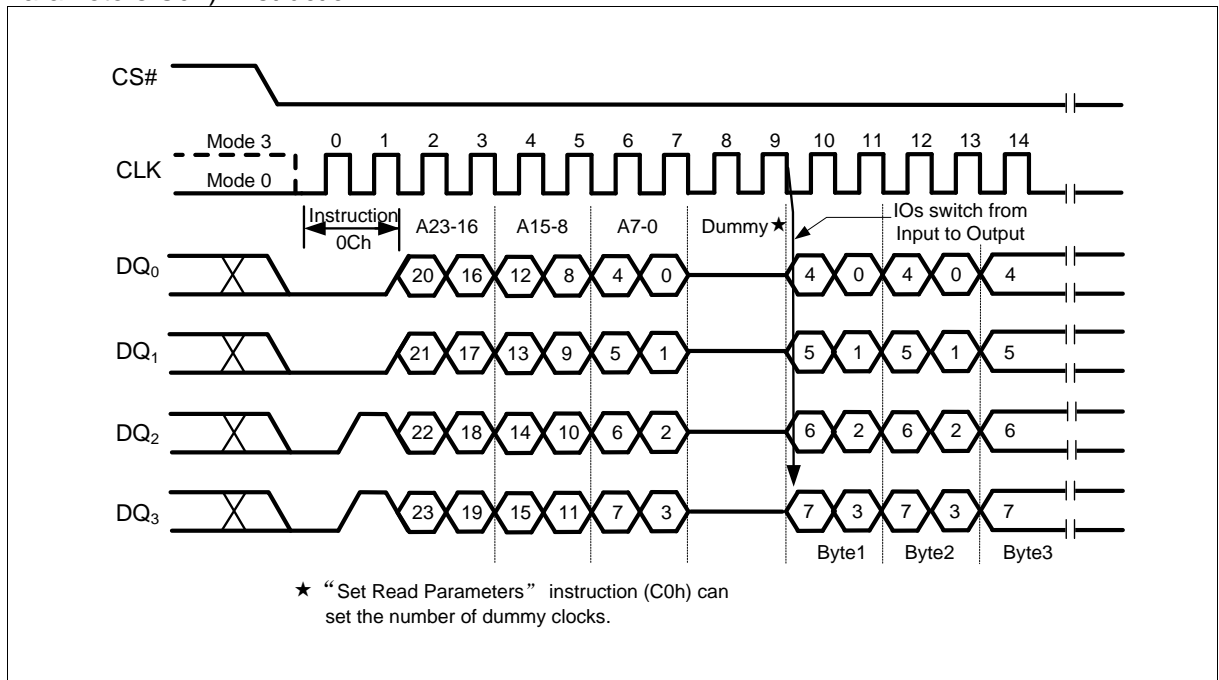

Figure 63 Burst Read with Wrap Instruction (QPI Mode only)

## 11.41. Enable QPI (38h)

The FM25Q64 support both Standard/Dual/Quad Serial Peripheral Interface (SPI) and Quad Peripheral Interface (QPI). However, SPI mode and QPI mode can not be used at the same time. “Enable QPI (38h)” instruction is the only way to switch the device from SPI mode to QPI mode.

Upon power-up, the default state of the device upon is Standard/Dual/Quad SPI mode. See Table 4~Table 6 Instruction Set for all supported SPI commands. In order to switch the device to QPI mode, the Quad Enable (QE) bit in Status Register 2 must be set to 1 first, and an “Enable QPI (38h)” instruction must be issued. If the Quad Enable (QE) bit is 0, the “Enable QPI (38h)” instruction will be ignored and the device will remain in SPI mode.

See Table 7 Instruction Set for all the commands supported in QPI mode.

When the device is switched from SPI mode to QPI mode, the existing Write Enable and the Wrap Length setting will remain unchanged.

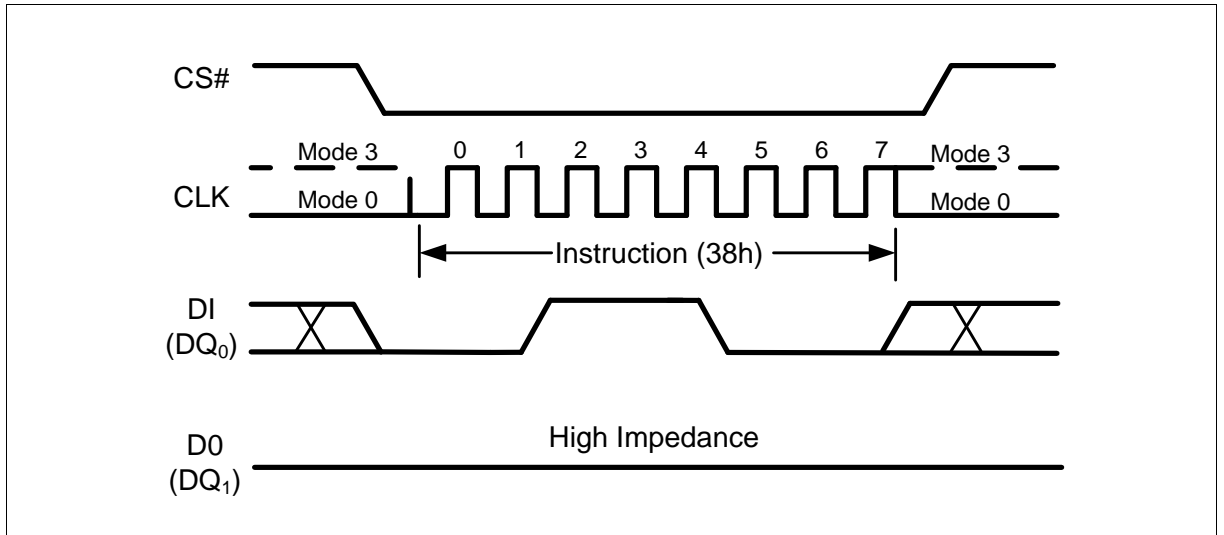

Figure 64 Enable QPI Instruction (SPI Mode only)

### 11.42. Disable QPI (FFh)

In order to exit the QPI mode and return to the Standard/Dual/Quad SPI mode, a “Disable QPI (FFh)” instruction must be issued.

When the device is switched from QPI mode to SPI mode, the existing Write Enable Latch (WEL) and the Wrap Length setting will remain unchanged.

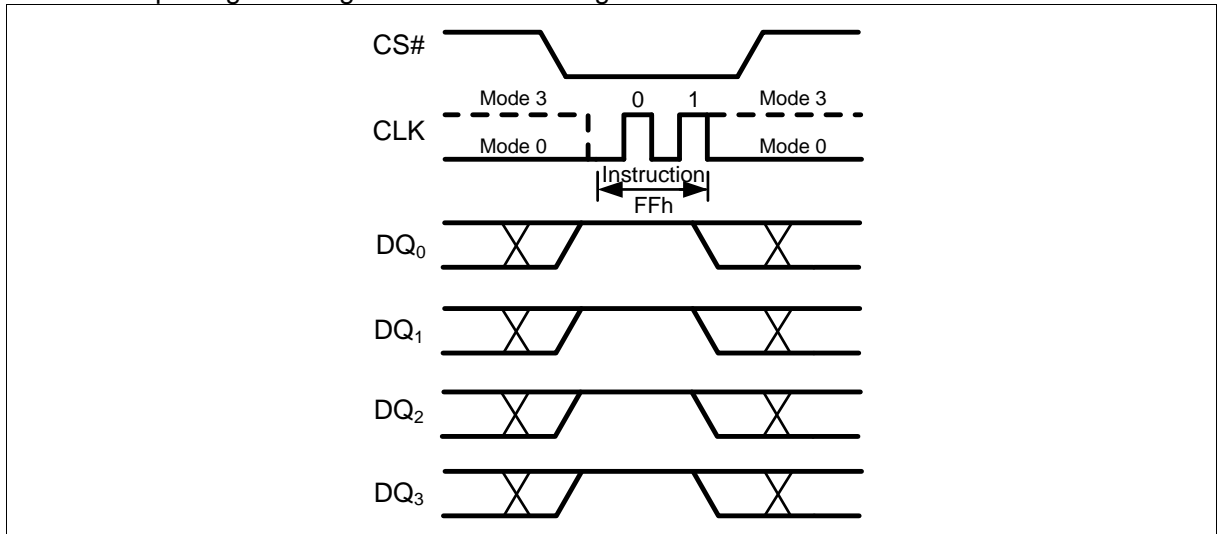

Figure 65 Disable QPI Instruction (QPI Mode only)

### 11.43. Enable Reset (66h) and Reset (99h)

Because of the small package and the limitation on the number of pins, the FM25Q64 provide a software Reset instruction instead of a dedicated RESET pin. Once the Reset instruction is accepted, any on-going internal operations will be terminated and the device will return to its default power-on state and lose all the current volatile settings, such as Volatile Status Register bits, Write Enable Latch (WEL) status, Read parameter setting P7-P0, Continuous Read Mode bit setting M7-M0 and Wrap Bit setting W6-W4.

“Enable Reset (66h)” and “Reset (99h)” instructions can be issued in either SPI mode or QPI mode. To avoid accidental reset, both instructions must be issued in sequence. Any other commands other than “Reset (99h)” after the “Enable Reset (66h)” command will disable the “Reset Enable” state. A new sequence of “Enable Reset (66h)” and “Reset (99h)” is needed to reset the device. Once the Reset command is accepted by the device, the device will take approximately  $t_{RST}=30\mu s$  to reset. During this period, no command will be accepted.

Data corruption may happen if there is an on-going or suspended internal Erase or Program operation when Reset command sequence is accepted by the device. It is recommended to check the BUSY bit and the SUS bit in Status Register before issuing the Reset command sequence.

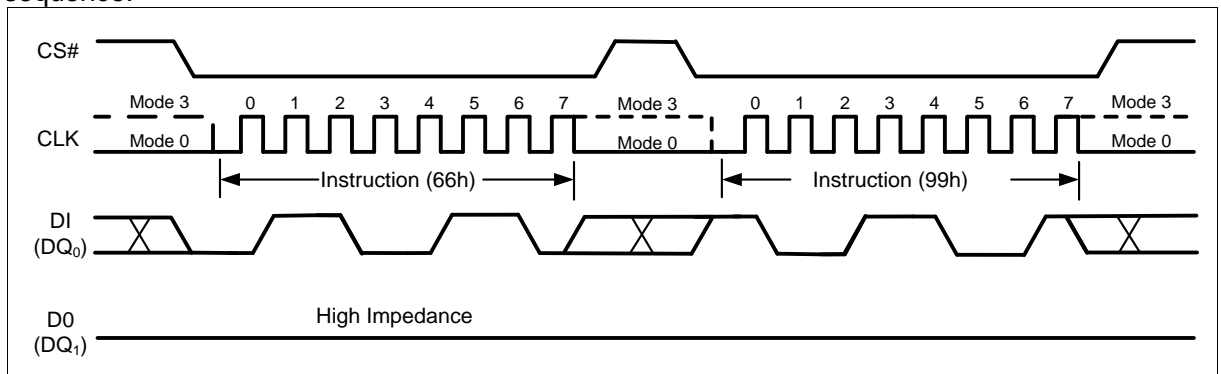

Figure 66 Enable Reset and Reset Instruction Sequence (SPI Mode)

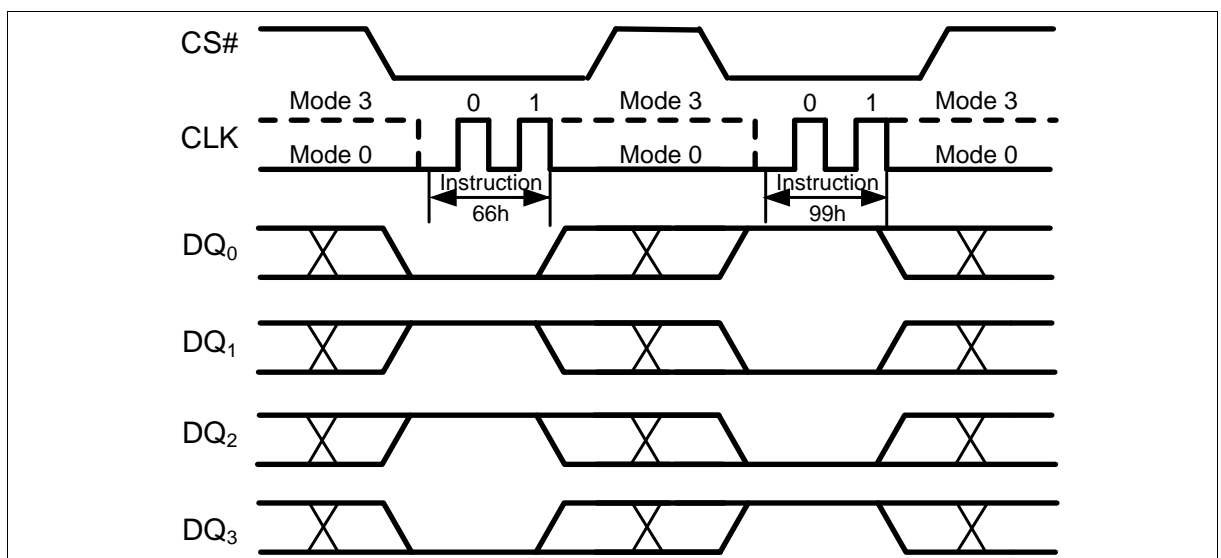

Figure 67 Enable Reset and Reset Instruction Sequence (QPI Mode)

## 12. Electrical Characteristics

### 12.1. Absolute Maximum Ratings

Operating Temperature	-40°C to +85°C
Storage Temperature	-65°C to +150°C
Voltage on I/O Pin with Respect to Ground	-0.5V to $V_{CC}+0.4V$
$V_{CC}$	-0.5V to 4.0V

\*NOTICE: Stresses beyond those listed under “Absolute Maximum Ratings” may cause permanent damage to the device. This is a stress rating only and functional operation of the device at these or any other conditions beyond those indicated in the operational sections of this specification are not implied. Exposure to absolute maximum rating conditions for extended periods may affect device reliability.

### 12.2. Pin Capacitance

PARAMETER	SYMBOL	CONDITIONS	Max	Units
Input Capacitance	$C_{IN}^{(1)}$	$V_{IN} = 0V, f = 5 \text{ MHz}$	6	pF
Output Capacitance	$C_{OUT}^{(1)}$	$V_{OUT} = 0V, f = 5 \text{ MHz}$	8	pF

**Note:** 1. This parameter is characterized and is not 100% tested.

### 12.3. Power-up Timing

Applicable over recommended operating range from:  $T_A = -40 \text{ }^\circ\text{C}$  to  $85 \text{ }^\circ\text{C}$ ,  $V_{CC} = 2.3V$  to  $3.6V$ , (unless otherwise noted).

SYMBOL	PARAMETER	SPEC		UNIT	
		MIN	MAX		
$t_{VSL}$	VCC (min) to CS# Low	10		$\mu\text{s}$	
$t_{PUW}$	Time Delay Before Write Instruction	1	10	ms	
$V_{WI}$	Write Inhibit Threshold Voltage	1	2	V	
$V_{PWD}$	VCC voltage needed to below $V_{PWD}$ for ensuring initialization will occur	Deep Power Down		0.4	V
		others		0.9	V
$t_{PWD}$	The minimum duration for ensuring initialization will occur	1		ms	

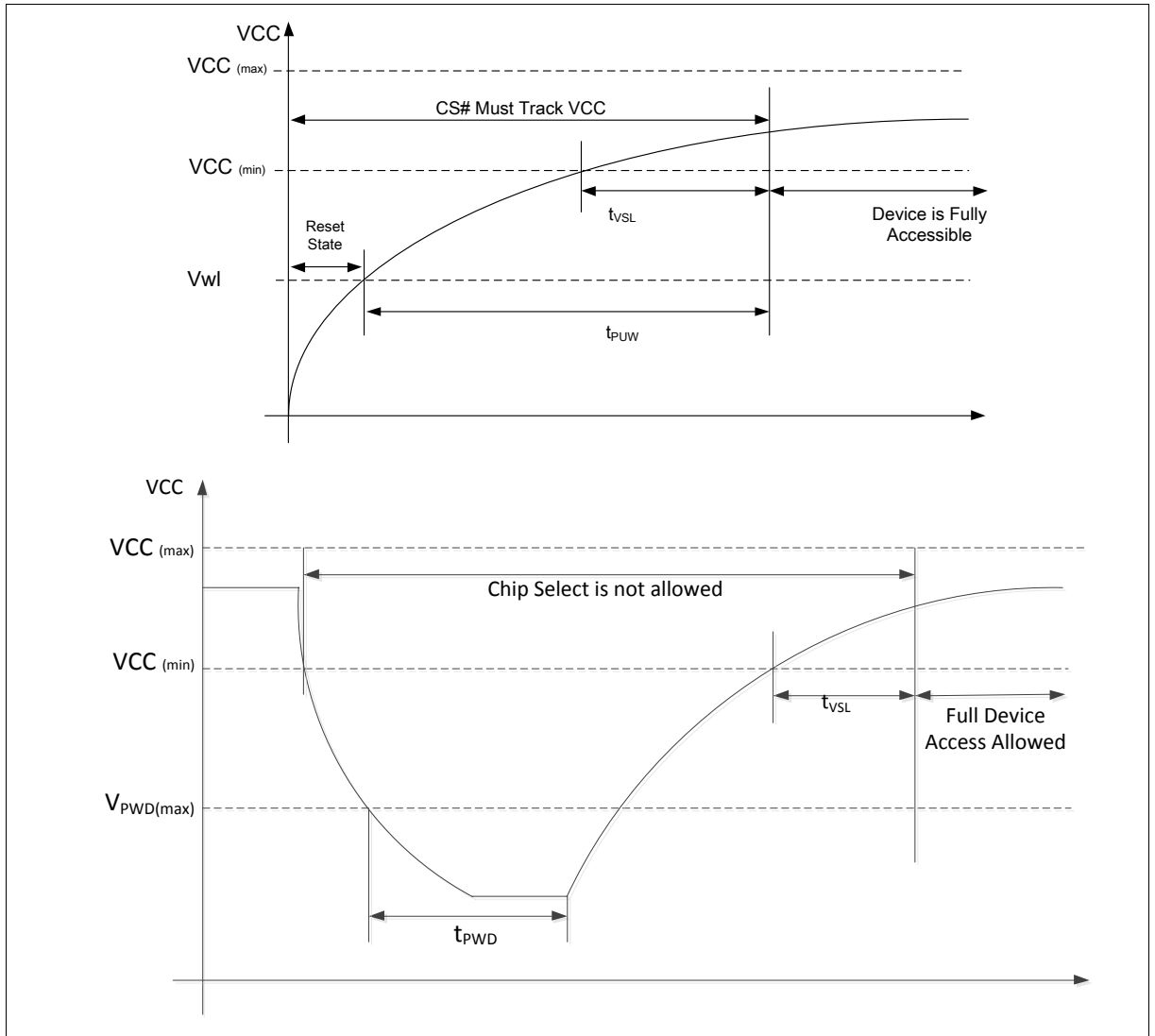

Figure 68 Power-up Timing & Power Up/Down and Voltage Drop

## 12.4. DC Electrical Characteristics

Table 8 DC Characteristics

Applicable over recommended operating range from:  $T_A = -40\text{ }^\circ\text{C}$  to  $85\text{ }^\circ\text{C}$ ,  $V_{CC} = 2.3\text{V}$  to  $3.6\text{V}$ , (unless otherwise noted).

SYMBOL	PARAMETER	CONDITIONS	SPEC			UNIT
			MIN	TYP	MAX	
$V_{CC}$	Supply Voltage		2.3		3.6	V
$I_{LI}$	Input Leakage Current				$\pm 2$	$\mu\text{A}$
$I_{LO}$	Output Leakage Current				$\pm 2$	$\mu\text{A}$
$I_{CC1}$	Standby Current	$CS\# = V_{CC}$ , $V_{IN} = V_{SS}$ or $V_{CC}$		1	5	$\mu\text{A}$
$I_{CC2}$	Deep Power-down Current	$CS\# = V_{CC}$ , $V_{IN} = V_{SS}$ or $V_{CC}$		1	5	$\mu\text{A}$
$I_{CC3}^{(1)}$	Read Data Current <sup>(1)</sup>	$CLK=0.1V_{CC}/0.9V_{CC}$ at 50MHz, DQ open			20	mA
$I_{CC3}^{(1)}$		$CLK=0.1V_{CC}/0.9V_{CC}$ , at 100MHz, DQ open			25	mA

SYMBOL	PARAMETER	CONDITIONS	SPEC			UNIT
			MIN	TYP	MAX	
$I_{CC4}$	Operating Current (WRSR)	$CS\#=V_{CC}$		8	12	mA
$I_{CC5}$	Operating Current (PP)	$CS\#=V_{CC}$		10	15	mA
$I_{CC6}$	Operating Current (SE)	$CS\#=V_{CC}$		10	15	mA
$I_{CC7}$	Operating Current (BE)	$CS\#=V_{CC}$		10	15	mA
$V_{IL}^{(2)}$	Input Low Voltage		-0.5		$0.3V_{CC}$	V
$V_{IH}^{(2)}$	Input High Voltage		$0.7V_{CC}$		$V_{CC}+0.4$	V
$V_{OL}$	Output Low Voltage	$I_{OL} = 1.6 \text{ mA}$			0.4	V
$V_{OH}$	Output High Voltage	$I_{OH} = -100 \mu\text{A}$	$V_{CC}-0.2$			V
$V_{WI}$	Write Inhibit Threshold Voltage		1.0		2.0	V

**Notes:**

1. Checker Board Pattern.
2.  $V_{IL}$  min and  $V_{IH}$  max are reference only and are not tested.

## 12.5. AC Measurement Conditions

Table 9 AC Measurement Conditions

SYMBOL	PARAMETER	SPEC		UNIT
		MIN	MAX	
CL	Load Capacitance		20	pF
TR, TF	Input Rise and Fall Times		5	ns
VIN	Input Pulse Voltages	0.2 V <sub>CC</sub> to 0.8 V <sub>CC</sub>		V
IN	Input Timing Reference Voltages	0.3 V <sub>CC</sub> to 0.7 V <sub>CC</sub>		V
OUT	Output Timing Reference Voltages	0.5V <sub>CC</sub>		V

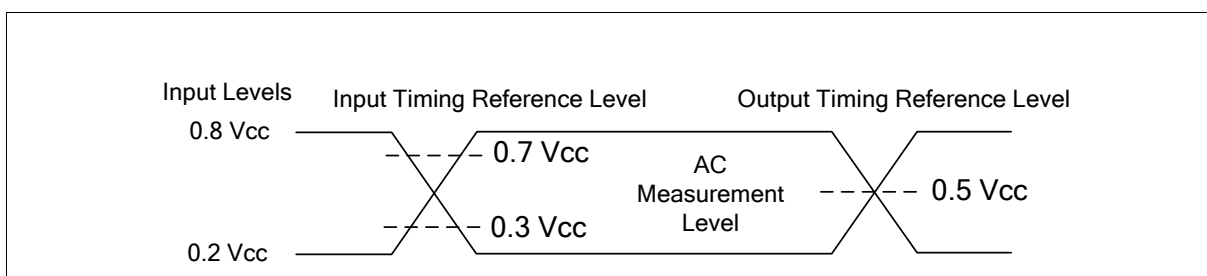

Figure 69 AC Measurement I/O Waveform

## 12.6. AC Electrical Characteristics

Table 10 AC Characteristics

Applicable over recommended operating range from: T<sub>A</sub> = -40 °C to 85 °C, V<sub>CC</sub> = 2.3V to 3.6V, (unless otherwise noted).

SYMBOL	PARAMETER	SPEC			UNIT
		MIN	TYP	MAX	
F <sub>R</sub>	Serial Clock Frequency for: FAST_READ, PP, SE, BE, DP, RES, WREN, WRDI, WRSR (2.3~2.7V/2.7~3.6V)			80/104	MHz
f <sub>R</sub>	Serial Clock Frequency for READ, RDSR, RDID (2.3~2.7V/2.7~3.6V)			33/66	MHz
t <sub>CH1</sub> <sup>(1)</sup>	Serial Clock High Time	3.5			ns
t <sub>CL1</sub> <sup>(1)</sup>	Serial Clock Low Time	3.5			ns
t <sub>CLCH</sub> <sup>(2)</sup>	Serial Clock Rise Time (Slew Rate)	0.1			V/ns
t <sub>CHCL</sub> <sup>(2)</sup>	Serial Clock Fall Time (Slew Rate)	0.1			V/ns
t <sub>SLCH</sub>	CS# Active Setup Time	5			ns
t <sub>CHSH</sub>	CS# Active Hold Time	5			ns
t <sub>SHCH</sub>	CS# Not Active Setup Time	5			ns
t <sub>CHSL</sub>	CS# Not Active Hold Time	5			ns
t <sub>SHSL</sub>	CS# High Time	7			ns
t <sub>SHQZ</sub> <sup>(2)</sup>	Output Disable Time			7	ns
t <sub>CLQX</sub>	Output Hold Time	0			ns
t <sub>DVCH</sub>	Data In Setup Time	1.5			ns
t <sub>CHDX</sub>	Data In Hold Time	4			ns
t <sub>HLCH</sub>	HOLD# Low Setup Time ( relative to CLK )	5			ns
t <sub>HHCH</sub>	HOLD# High Setup Time ( relative to CLK )	5			ns

SYMBOL	PARAMETER	SPEC			UNIT
		MIN	TYP	MAX	
t <sub>CHHH</sub>	HOLD# Low Hold Time ( relative to CLK )	5			ns
t <sub>CHHL</sub>	HOLD# High Hold Time ( relative to CLK )	5			ns
t <sub>HLQZ</sub> <sup>(2)</sup>	HOLD# Low to High-Z Output			12	ns
t <sub>HHQX</sub> <sup>(2)</sup>	HOLD# High to Low-Z Output			7	ns
t <sub>CLQV</sub>	Output Valid from CLK			7	ns
t <sub>WHSL</sub>	Write Protect Setup Time before CS# Low	20			ns
t <sub>SHWL</sub>	Write Protect Hold Time after CS# High	100			ns
t <sub>DP</sub> <sup>(2)</sup>	CS# High to Deep Power-down Mode			3	μs
t <sub>RES1</sub> <sup>(2)</sup>	CS# High to Standby Mode without Electronic Signature Read			3	μs
t <sub>RES2</sub> <sup>(2)</sup>	CS# High to Standby Mode with Electronic Signature Read			1.8	μs
t <sub>SUS</sub> <sup>(2)</sup>	CS# High to next Instruction after Suspend			30	μs
t <sub>RST</sub> <sup>(2)</sup>	CS# High to next Instruction after Reset			40	μs
t <sub>W</sub>	Write Status Register Cycle Time		10	15	ms
t <sub>BP</sub>	Byte Program Time		60	100	μs
t <sub>PP</sub>	Page Program Time		0.6	2	ms
t <sub>SE</sub>	Sector Erase Time (2.3~2.7V/2.7~3.6V)		45/35	300	ms
t <sub>BE</sub>	Block Erase Time (32KB) (2.3~2.7V/2.7~3.6V)		150/120	700	ms
	Block Erase Time (64KB) (2.3~2.7V/2.7~3.6V)		200/150	1000	ms
t <sub>CE</sub>	Chip Erase Time(2.3~2.7V/2.7~3.6V)		30/20	80	s

**Notes:**

1.  $t_{CH} + t_{CL} \geq 1 / F_R$  or  $1 / f_R$  ;
2. This parameter is characterized and is not 100% tested.

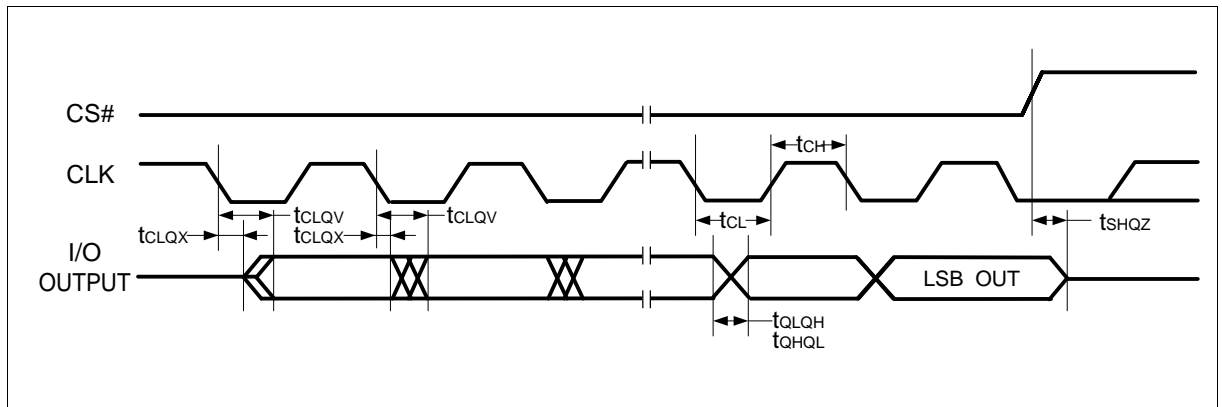

Figure 70 Serial Output Timing

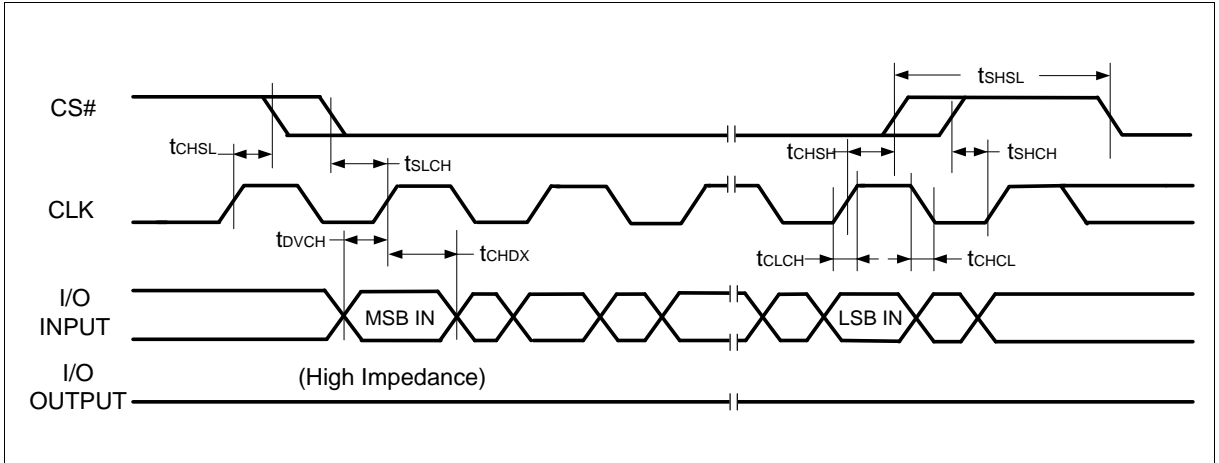

Figure 71 Serial Input Timing

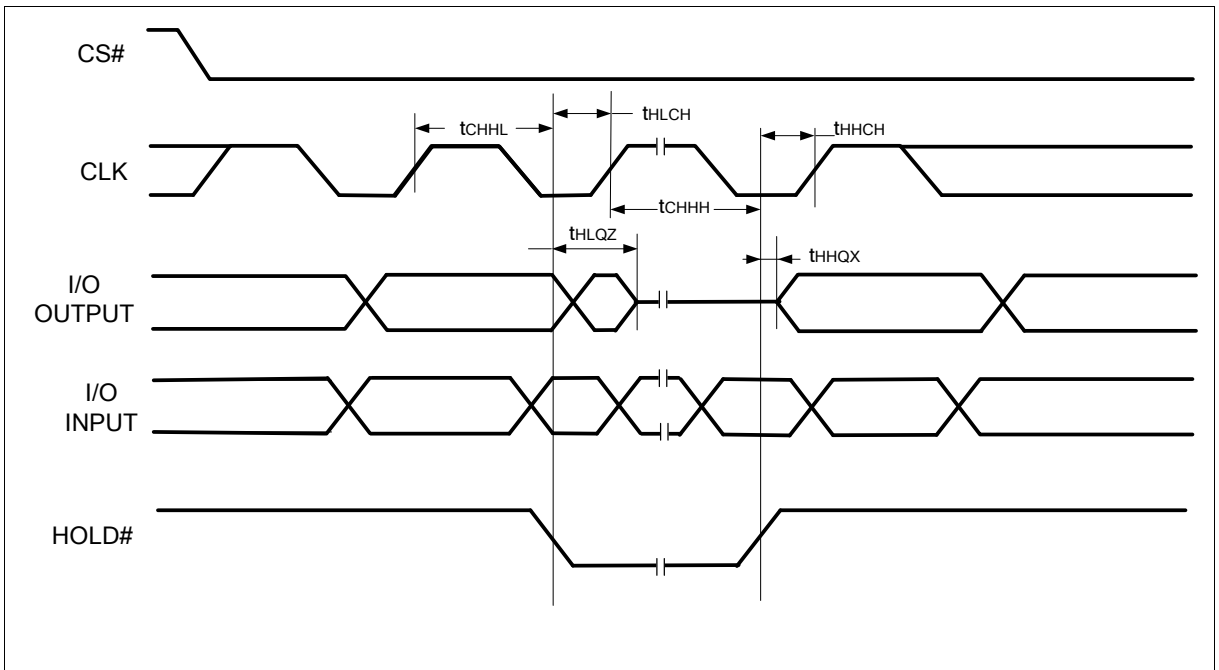
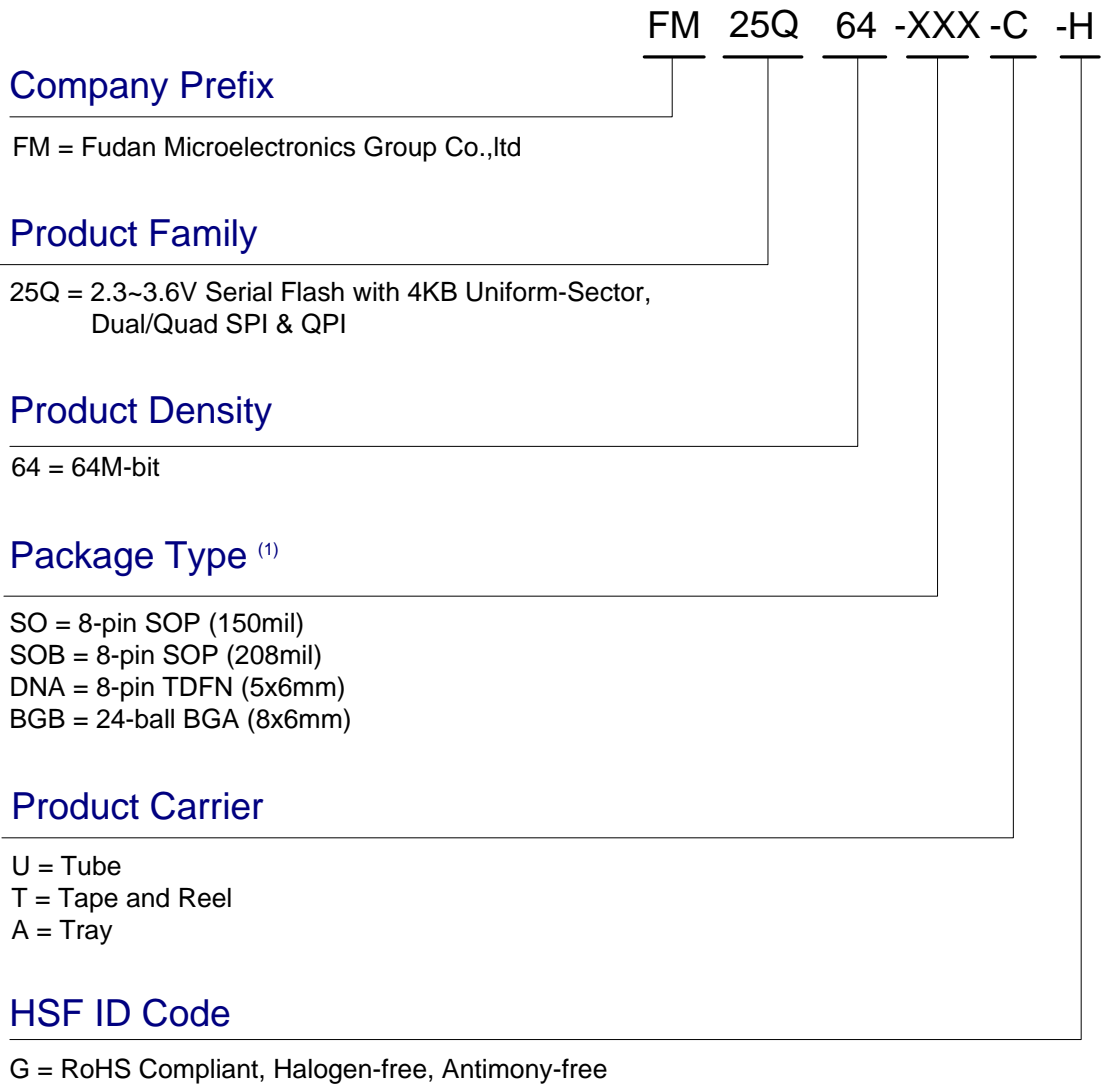

Figure 72 Hold Timing



# 13. Ordering Information



Note:

- For SO package, MSL1 package are available, for detail please contact local sales office.

## 14. Part Marking Scheme

### 14.1. SOP8 (150mil)

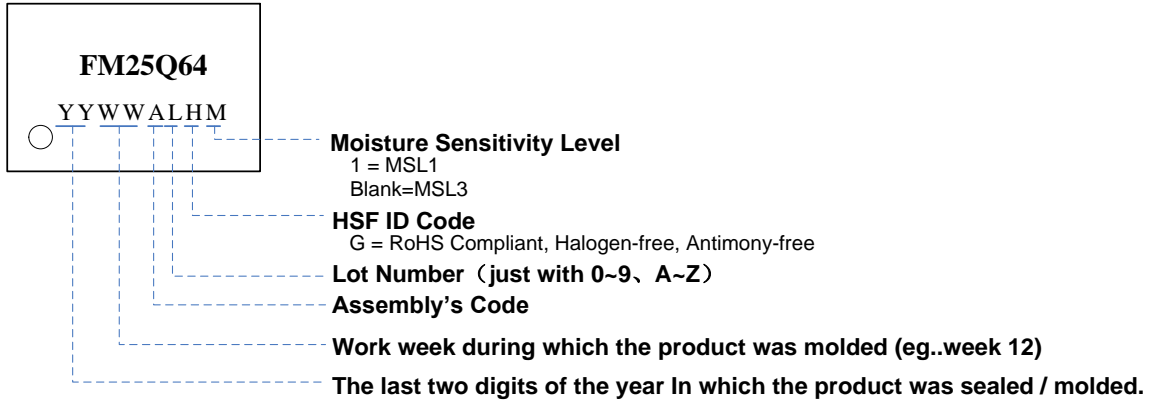

### 14.2. SOP8 (208mil)

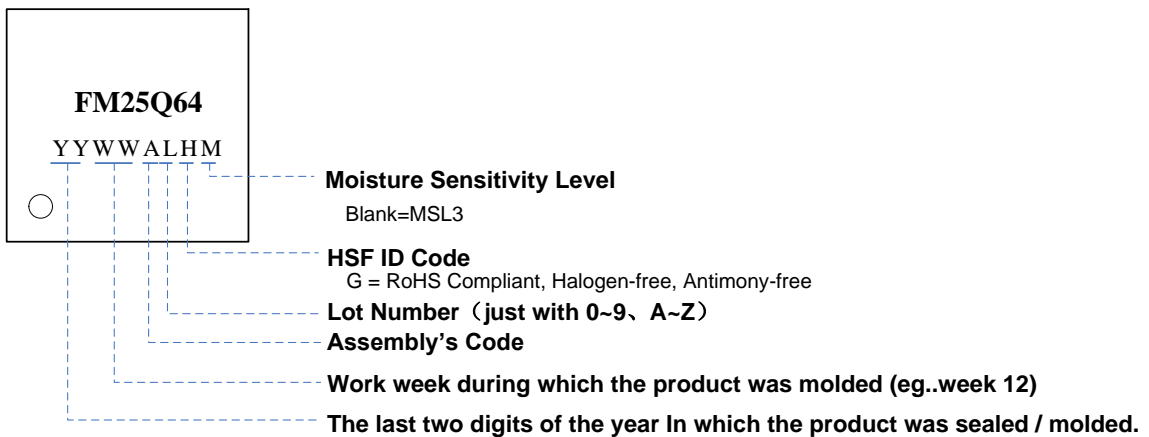

### 14.3. TDFN8 (5x6mm)

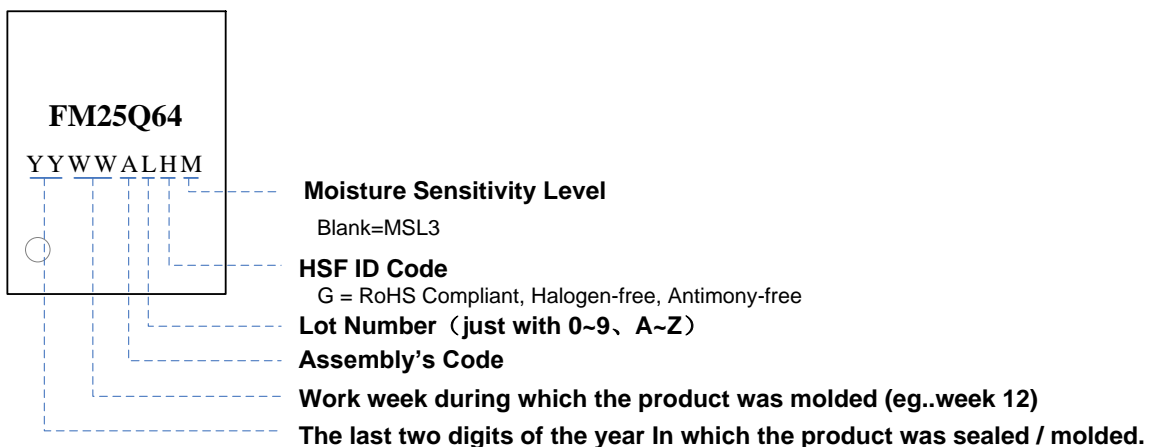

## 14.4. BGA24 (8x6mm)



FM25Q64  
 \_\_\_\_\_ Product Density

YYWWALH  
 \_\_\_\_\_ HSF ID Code  
     G = RoHS Compliant, Halogen-free, Antimony-free  
 \_\_\_\_\_ Package Lot Number (just with 0~9, A~Z)  
 \_\_\_\_\_ Assembly's Code  
 \_\_\_\_\_ Work week during which the product was molded (eg..week 12)  
 \_\_\_\_\_ The last two digits of the year in which the product was sealed/molded

XXXXXXXX  
 \_\_\_\_\_ Wafer Lot Number (the length is not fixed)

## 15. Packaging Information

SOP8 (150mil)

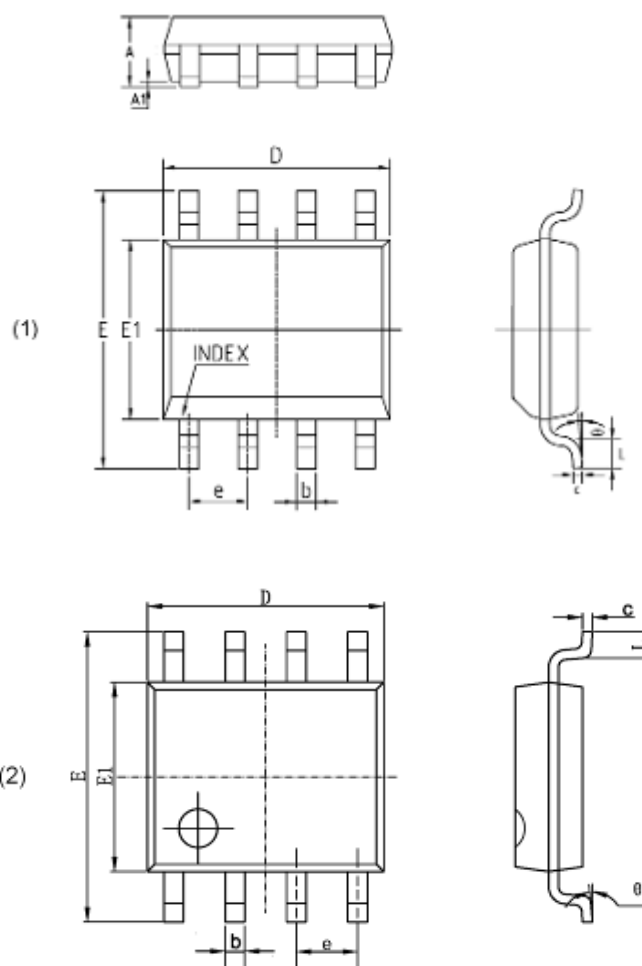

Symbol	MIN	MAX
A	1.350	1.750
A1	0.050	0.250
b	0.330	0.510
c	0.150	0.260
D	4.700	5.150
E1	3.700	4.100
E	5.800	6.200
e	1.270(BSC)	
L	0.400	1.270
$\theta$	0°	8°

**NOTE:**

1. Dimensions are in Millimeters.

## SOP8 (208mil)

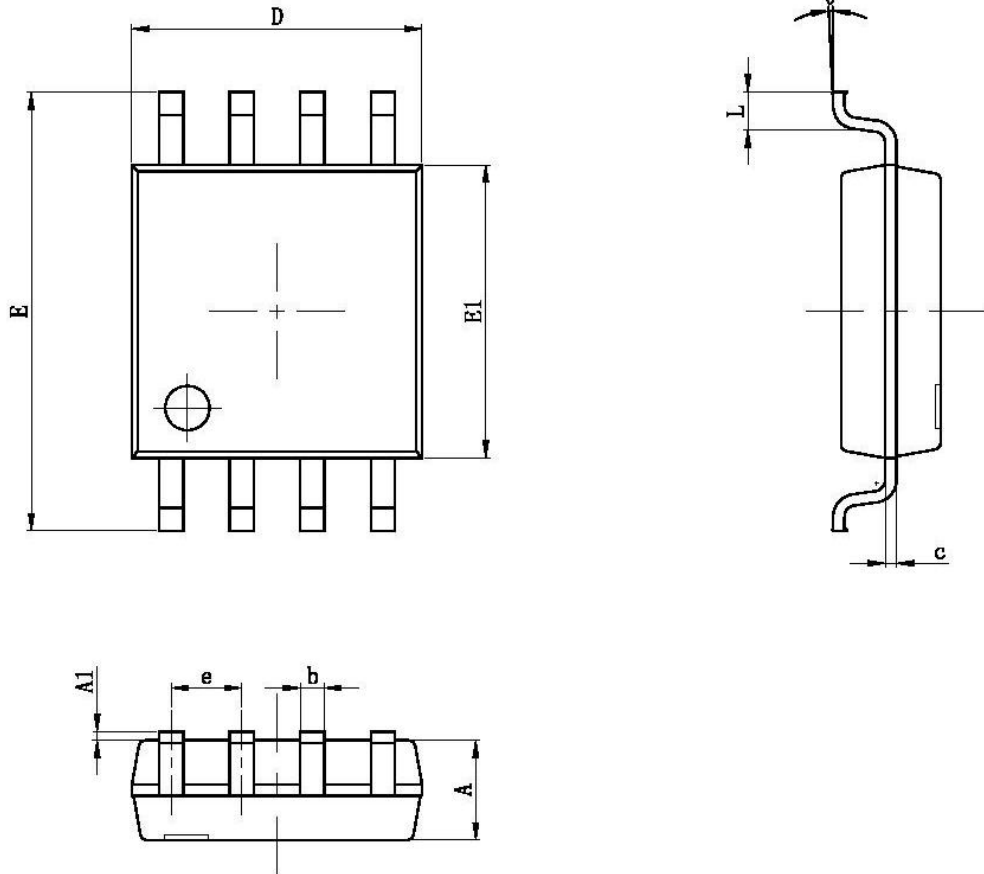

Symbol	MIN	MAX
A	--	2.100
A1	0.050	0.250
b	0.350	0.500
c	0.100	0.250
D	5.130	5.330
E1	5.180	5.380
E	7.700	8.100
e	1.270(BSC)	
L	0.500	0.850
$\theta$	0°	8°

## NOTE:

- Dimensions are in Millimeters.

TDFN8 (5x6mm)

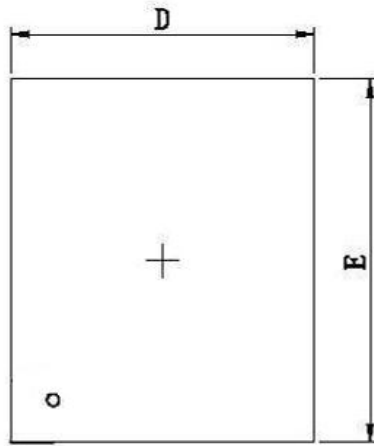

Top View

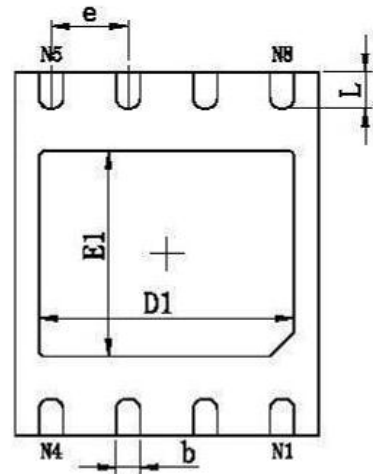

Bottom View

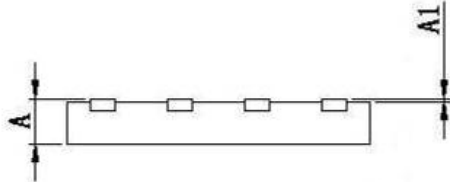

Side View

Symbol	MIN	MAX
A	0.700	0.800
A1	0.000	0.050
D	4.924	5.076
E1	3.300	3.500
E	5.924	6.076
b	0.350	0.450
e	1.270TYP	
L	0.524	0.676

NOTE:

1. Dimensions are in Millimeters.

### BGA24 (8x6mm)

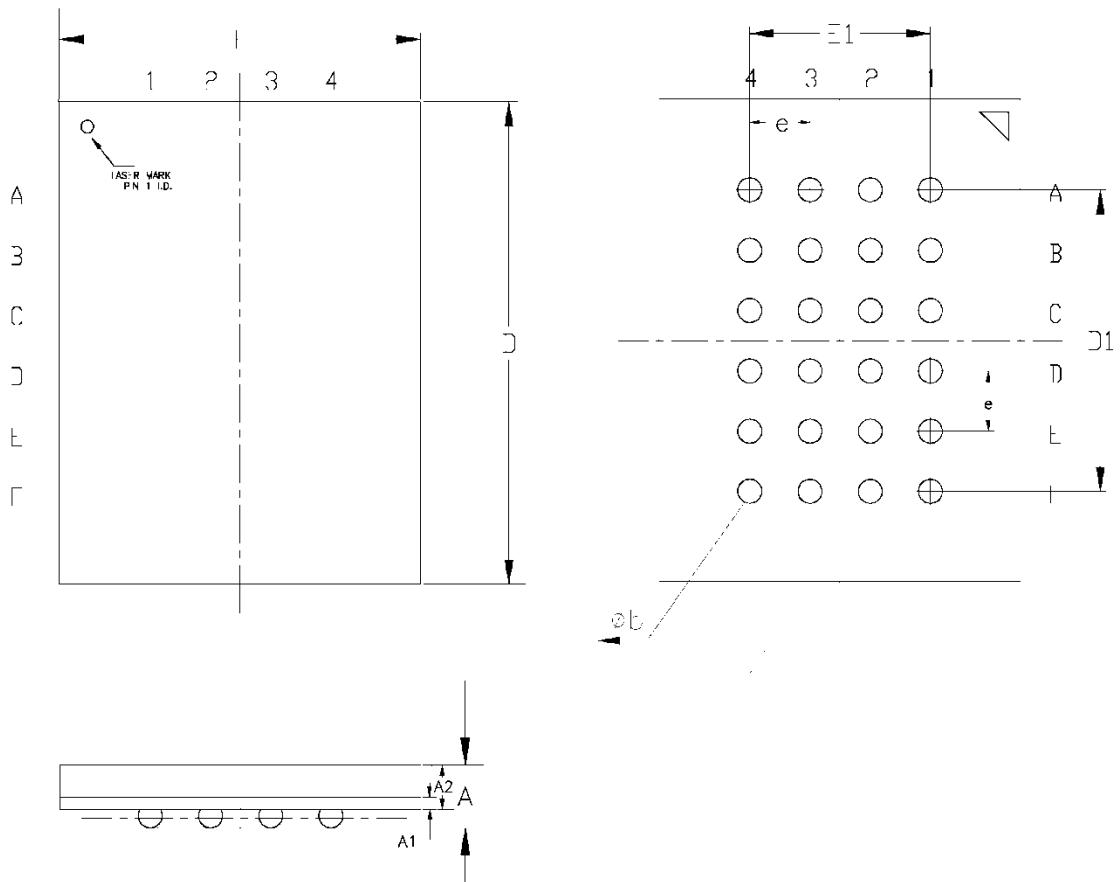

Symbol	MIN	MAX
A	---	1.20
A1	0.17	0.25
A2	0.69	0.79
D	7.90	8.10
D1	5.00 BSC	
E	5.90	6.10
E1	3.00 BSC	
e	1.00 BSC	
b	0.350	0.450

**Note:**  
1. Dimensions are in Millimeters.