

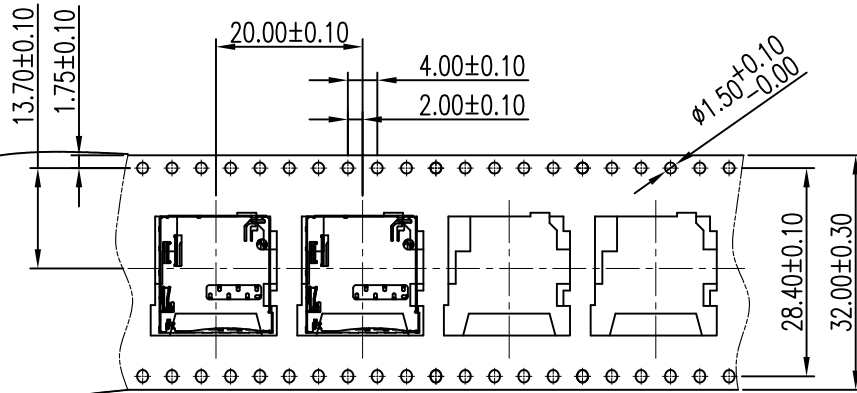



RoHS

User Direction of Unreeling →



COVER TAPE PEELING ANGLE: 165°~180°  
PEELING FORCE: 20~130g  
CARRIER TAPE

User Direction of Unreeling →

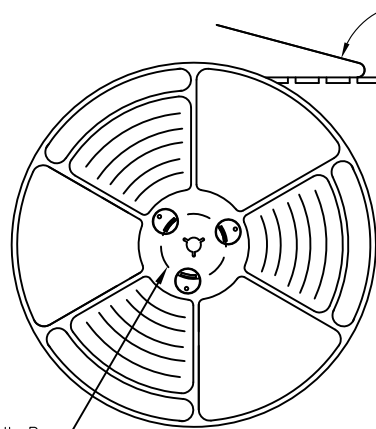

DETAIL B

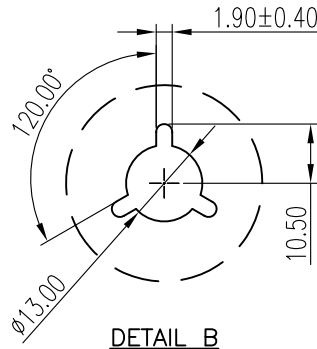

DETAIL B

NOTES

1. NUMBER OF CONNECTORS: 1000PCS/REEL
2. LEAD TAPE LENGTH

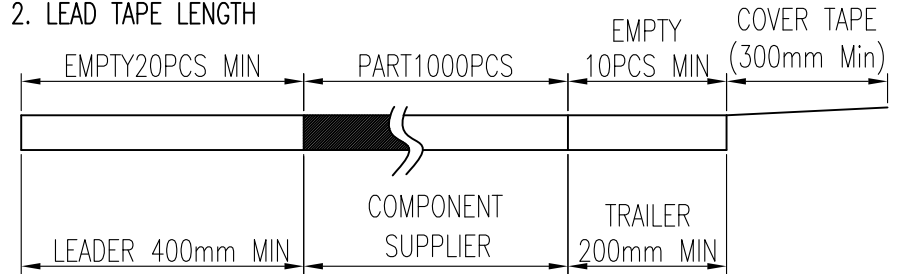

3. QUANTITY: 7000PCS/CARTON

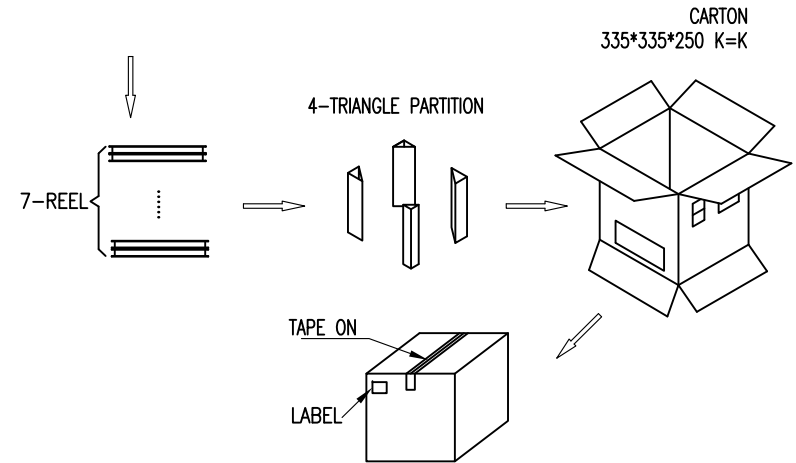

MILLIMETERS	INCH	UNITS	MM		
X° ± 2'	X° ± 2'	MAT'L	DongGuan JinBiLai Metal Plastic Technology Co.,Ltd		
.X ± 0.38	.XX ± 0.015	SEE NOTES	PART NUMBER: 102314342-B		TITLE: 1.27mm (DIP:1.4mm) Push Micro Sim
.XX ± 0.25	.XXX ± 0.010	FINISH	APPD:		DWG NO.:
.XXX ± 0.15	.XXXX ± 0.006	SEE NOTES	CHKD:		C-102314342-00
THESE DRAWINGS AND SPECIFICATIONS ARE THE PROPERTY OF DongGuan JinBiLai Metal Plastic Technology Co.,Ltd. COPIED OR USED IN ANY MANNER WITHOUT THE PRIOR WRITTEN CONSENT OF DongGuan JinBiLai Metal Plastic Technology Co.,Ltd			QTY	DR:	SCALE
			SEE NOTES		1:1
					SHEET
					3/3
					REV.
					A1