

## SCM1209A 9-24V Transformer Driver for Isolated Power Supplies

### Features

- Push-Pull Driver for Small Transformers
- Two built-in power MOSFET and Simple application circuit
- Limited MOSFET current at start-up
- Output short circuit protection and over temperature protection with self-recovery function
- Under voltage protection
- 9~24V wide input voltage, 3.3-24V output voltage
- 220uF-4000uF capacitive load

### Application

- Isolated Interface Power Supply for CAN, RS-485, RS-232
- DC-DC Isolation Converter
- Distributed generation resources

### Packaging

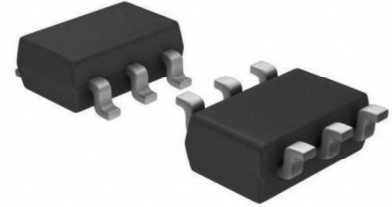

Optional Packaging of Product: TSOT-23-6, please refer to "Ordering Information" for details of silk screen.

### Function Description

The SCM1209A is a push-pull driver for the primary side of small transformers, specifically designed for small form factor isolated power supplies in isolated interface applications. The SCM1209A can be applied to isolation converter with simple application circuit, which can realize 9-24V input voltage and 1-3W power with 3-24V input voltage. The device contains one oscillator, two drive systems and two power MOSFET, and each drive system decides circuit's direction of one primary winding. Each drive system includes one power NMOSFET. Two drive systems operate in turns to achieve push-pull drive, and the power MOSFETs can be turned on or off via internal logic circuit. The SCM1209A is also integrated with different kinds of protection, such as under voltage protection and over temperature protection, which improve reliability. Its soft start function can avoid impulse heavy current; the short circuit timing system and current limit driver system ensure the capacitive load capacity and short circuit protection. The chip can adjust short circuit threshold voltage based on input voltage and temperature, which is good for consistency.

### Typical Application Circuit

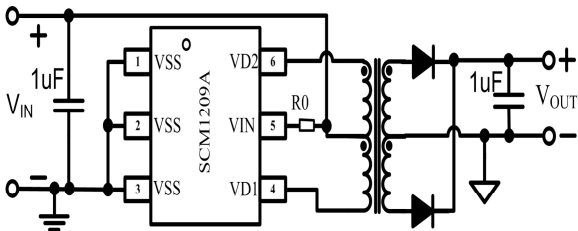

### Function Curves

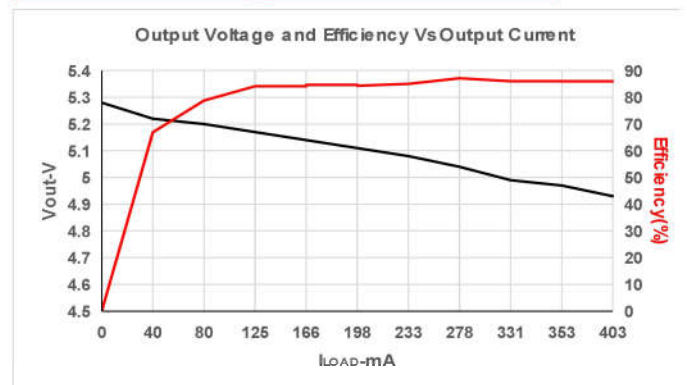

2020-10-13 正本 orig •

1	Features.....	1
2	Packaging.....	1
3	Application.....	1
4	Function Description.....	1
5	Typical Application Circuit.....	1
6	Function Curves.....	1
7	Pin Packaging.....	2
8	Inter Block Diagram.....	2
9	Pin Description.....	2
10	Absolute Maximum Ratings.....	3

## Contents

12	Thermal Resistance Information.....	3
13	Electrical Characteristics.....	3
14	Typical Performance Curves.....	4
15	Parameter Measurement Information.....	4
16	Features Description.....	5
17	Functional Modes.....	6
18	Extend Output Design.....	8
19	Application circuit.....	9
20	Suggestions of Power Use.....	9
21	Order, Packaging and Packing.....	9

### Pin Packaging

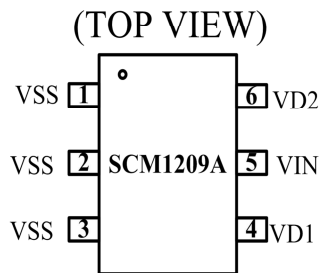

### Inter Block Diagram

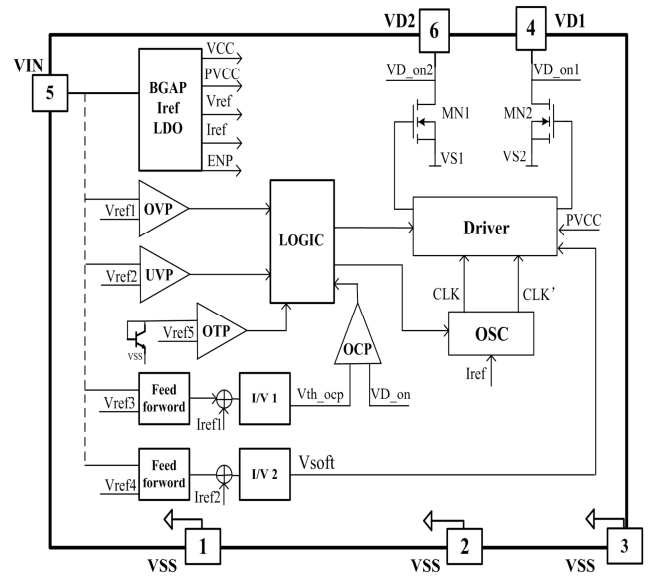

### Pin Description

Pin Number	Name	I/O	Description
2	VSS	I	Device ground. Connect this pin to board ground.
1,3	VSS	I	Pin1 and Pin3 is connected to the source of the power MOSFETs.
	VSS	I	
4	VD1	I	Open Drain output of the first power MOSFET. Connect this pin to one end of the transformer primary side.
6	VD2	I	Open Drain output of the second power MOSFET. Connect this pin to the other end of the transformer primary side.
5	VIN	P	Supply voltage input.

2020-10-13 正本 orig •

## Absolute Maximum Ratings

General test conditions: Free-air, normal operating temperature range (unless otherwise specified).

Parameters		Min	Max	Unit
Input Voltage	$V_{VIN}$	-0.4	72	V
Drain Voltage of MOSFET	$V_{VD1}/V_{VD2}$	-0.7	72	V
Operation Junction Temperature Range	$T_J$	-40	150	°C
Storage Temperature	$T_{STG}$	-55	150	
Soldering Temperature (Allowable reflow soldering temperature of chip within 10 seconds)			260	
Rated Value of ESD	HBM		2500	V
	CDM		1000	

Note: if the value exceeds the stress value listed in the table's "maximum value", it may cause permanent damage to the components. If the product operates in the maximum rated condition for a long time, the reliability of the components may be affected. All voltage values take GND as basis reference. The current refers to the current between positive input and negative output of the specified terminal.

## Recommended Operating Conditions

Unless otherwise specified, the following parameters are measured in the conditions of  $V_{VIN}=24V$ .

Parameters		Min	Max	Unit
Input Voltage	$V_{VIN}$	8	30	V
Drain Voltage of MOSFET	$V_{VD1}/V_{VD2}$	0	60	V
Output Switching Current of Primary Winding	$I_{D1}, I_{D2}$	300	600	mA
VD1,VD2 average switching frequency	$F_{SW}$	238	282	KHz
Operation Junction Temperature	$T_J$	-40	125	°C

## Electrical Characteristics

Unless otherwise specified,  $V_{VIN}=24V$  and the environment temperature is 25°C.

Symbol	Corresponding Parameters	Test Conditions	Min	Typ	Max	Unit
<b>Voltage Supply (VIN Pin)</b>						
$V_{VIN}$			8.1		30	V
$I_{RUN}$	Operating Current of Chip	No connection to VD1 and VD2		0.85	1	mA
$I_{START}$	$I_{VIN}$ when $V_{VIN}$ is in under-voltage lockout	$V_{VIN}=3V$			350	µA
$V_{VIN\_ON}$	Start-up Voltage	$V_{VIN}$ voltage increasing		7.5		V
$V_{VIN\_OFF}$	Voltage when $V_{VIN}$ is in under-voltage lockout	$V_{VIN}$ voltage decreasing		6.7		V
$V_{VIN\_OVP}$	Voltage when $V_{VIN}$ is In over voltage protection	$V_{VIN}$ voltage increasing		35.2		V
$V_{OVP\_OFF}$	Voltage when $V_{VIN}$ is In over voltage lockout	$V_{VIN}$ voltage decreasing		28.8		V
$T_{OTP}$	Temperature of Over-temperature Protection	Temperature increasing		156		°C
$T_{OTPH}$	Return Difference of Over-temperature Protection	Temperature decreasing		25		°C
<b>Drain Output of MOSFET (VD1/VD2 Pin)</b>						
$B_{VDSS}$	Breakdown Voltage of MOS Transistor	$V_{GATE}=0V, I_{DS}=100\mu A$	72	80		V
$R_{DS\_ON}$	On Resistance	$V_{VIN}=24V, T_J=25^\circ C, I_{DS}=0.5A$		1		Ω
		$V_{VIN}=24V, T_J=100^\circ C, I_{DS}=0.5A$		1.5		
$I_{SOFT}$	Current of Soft Start	$V_{VIN}=9V, V_{VD1}=V_{VD2}=5V$	500		650	mA
		$V_{VIN}=24V, V_{VD1}=V_{VD2}=5V$	200		300	
<b>Internal Time Parameters</b>						
$F_{OSC}$	Operating Frequency	No connection to VD1 and VD2		260		kHz
$T_{DEAD}$	Maximum dead time	VD1,VD2 is in series with 100Ω/1W power resistance		150		ns
$T_{D\_OSP}$	Delay Time of Short Circuit Protection	At a Fixed Operating Frequency( $f_{sw}$ ) $T=1/f_{sw}$		$2^{12}+2^{13}$		T
$T_{SLEEP}$	Sleep Time of Short Circuit Protection	At a Fixed Operating Frequency( $f_{sw}$ ) $T=1/f_{sw}$		$2^{18}$		T

2020-10-13 正本 orig •

## Typical Performance Curves

Unless otherwise specified, the following typical characteristic curves are obtained in the conditions of  $V_{IN}=24V$  and  $T=25^{\circ}C$ . Typical performance curves are obtained by testing the test circuit shown in Figure 5 and Figure 7.

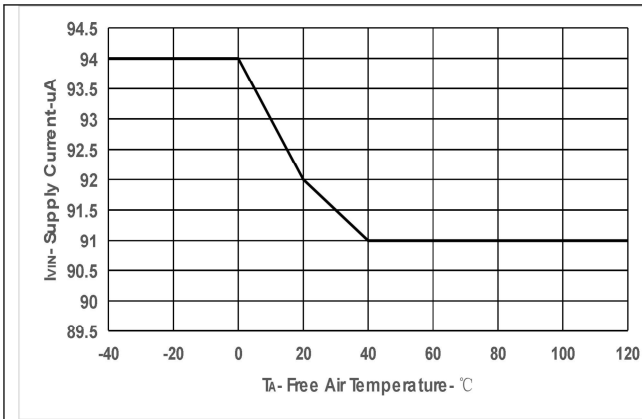

Figure 1 Average Supply Current of VIN VS Free Air Temperature

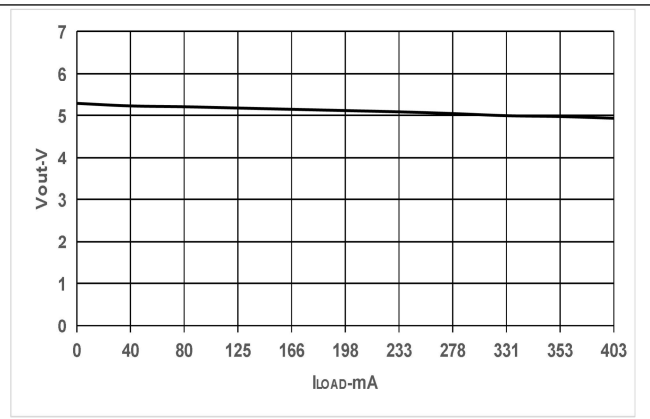

Figure 2 Output Voltage VS Load Current

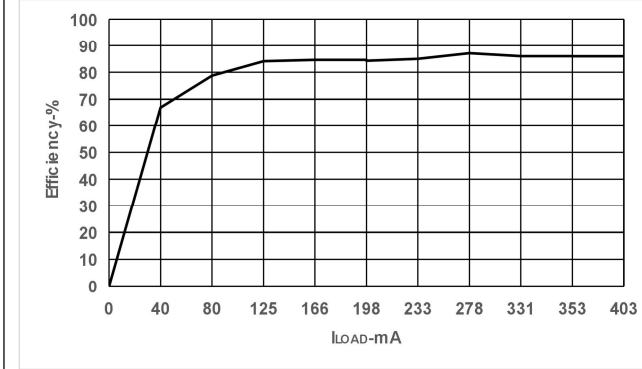

Figure 3 Efficiency VS Load Current

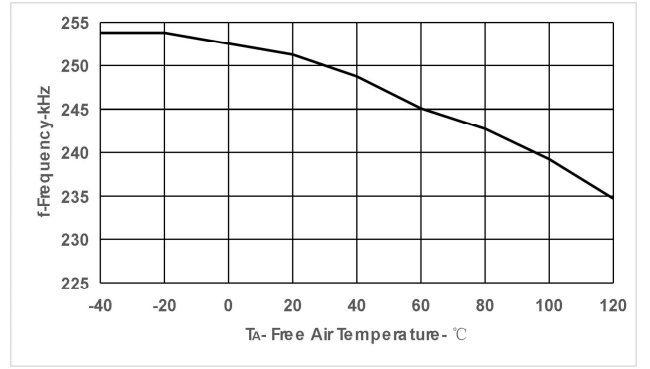

Figure 4 MOSFET Switching Frequency VS Environment Temperature

## Parameter Measurement Information

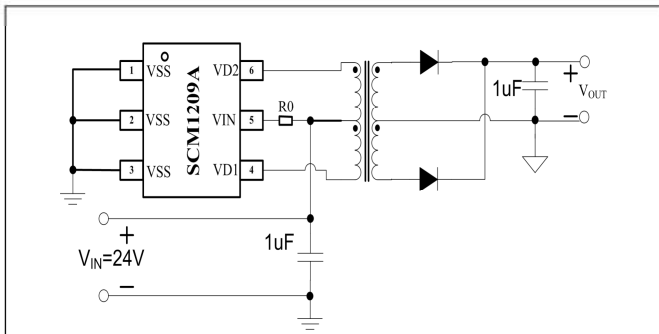

Figure 5 Schematic Diagram of Test Circuit for Function Curve

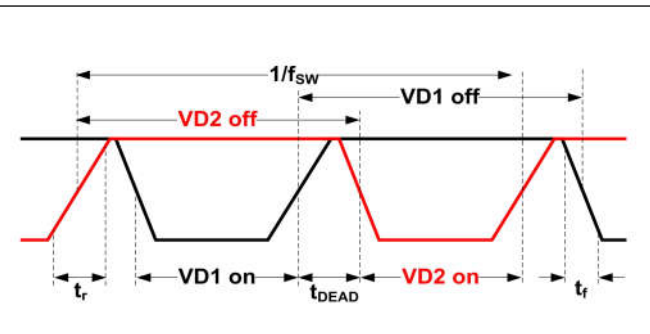

Figure 6 Circuit Sequence Diagram

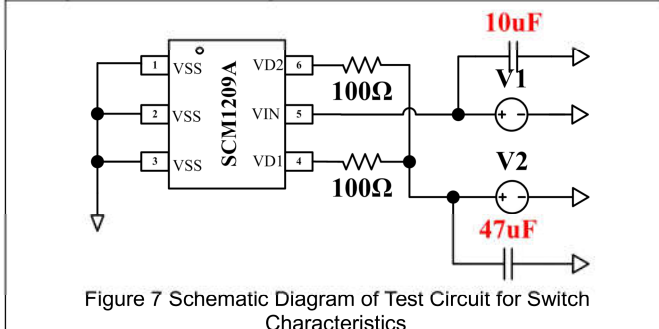

Figure 7 Schematic Diagram of Test Circuit for Switch Characteristics

2020-10-13 正本 orig •

(1) Push-pull Converter

As shown in Figure 8 and Figure 9, the push-pull converter is a transformer with center tap, which can achieve the transmission of energy from the primary winding to secondary winding.

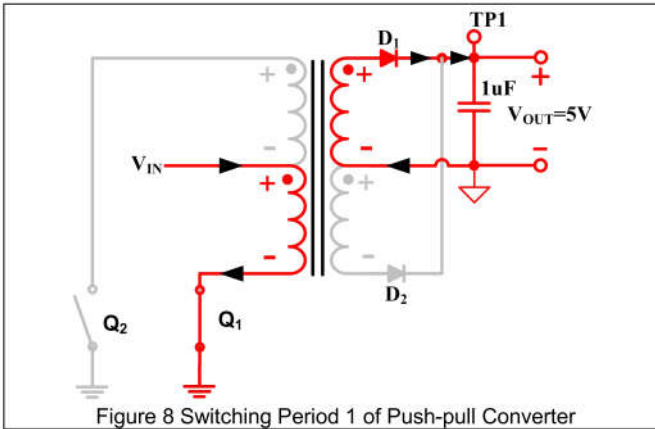

Figure 8 Switching Period 1 of Push-pull Converter

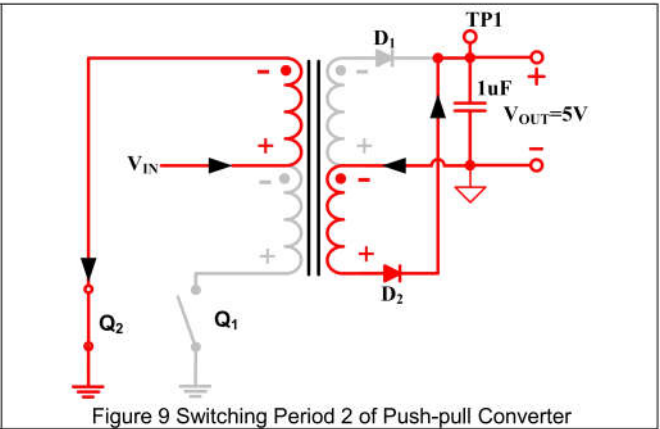

Figure 9 Switching Period 2 of Push-pull Converter

The drive waveform of drains VD1 and VD2 of two MOSFETs Q1 and Q2 are shown in Figure 6. Two MOS transistors are on alternatively and the times of the breakover periods of two transistors are equal, and there is a short period  $t_{BBM}$  between the two breakover periods that the two power transistors are not on. That is to say, the drive levels of two MOS transistors are quasi complementary in time sequence, that is the other transistor is off when one transistor is on, but there is a short period of dead time during the switch to prevent the backward current flow when two the transistors are not on simultaneously. As shown in red highlighted parts in Figure 8, when Q1 is on, input voltage  $V_{IN}$  drives a current which arrives at the reference ground through the lower half of primary winding of transformer and Q1, and at the same time, the induced electromotive force of side winding charges output capacitor through diode D1, similarly, as shown in Figure 9, when Q2 is on, the induced electromotive force charges output capacitor through diode D2. As continuously repeating the above process, the secondary winding of power converter obtain the needed power supply.

(2) Magnetization of Magnetic Core

Figure 10 is the ideal magnetization curve of push-pull converter, and the vertical axis represents magnetic flux density B and the horizontal axis represents magnetic field intensity H. When Q1 is on, the magnetic flow is pushed to point A' from point A, similarly, when Q2 is on, the magnetic flow is then pulled back to point A from point A'. The magnetic flux density B is proportional to the product of voltage of primary winding  $V_{LP}$  and breakover time of MOS transistors  $t_{ON}$ , which can be described in the following formula:

$$B \propto V_{LP} \times t_{ON}$$

The volt-second product  $V_{LP} \times t_{ON}$  defines the magnetization degree of each switching period. If the volt-second products in the above "push" and "pull" periods are not identical, a small direct current component may be generated to cause the deviation of magnetic flow. If balance cannot be restored, the deviation of magnetic flow will gradually increase in the each of the following switching period, making magnetic core become saturated gradually. The phenomenon of the deviation of magnetic flow is usually caused by the unequal on resistance or switching speed of two power switching components. Although the on resistance or switching speed of the two power components are approximately equal through integrating them into the same wafer with the help of high matching advantage of semiconductor integrated circuit technology, the manufacturing error still exists, causing the small deviation for the breakover time.

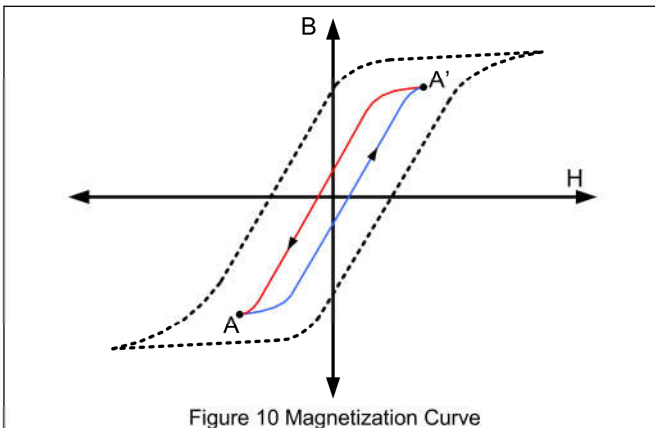

Figure 10 Magnetization Curve

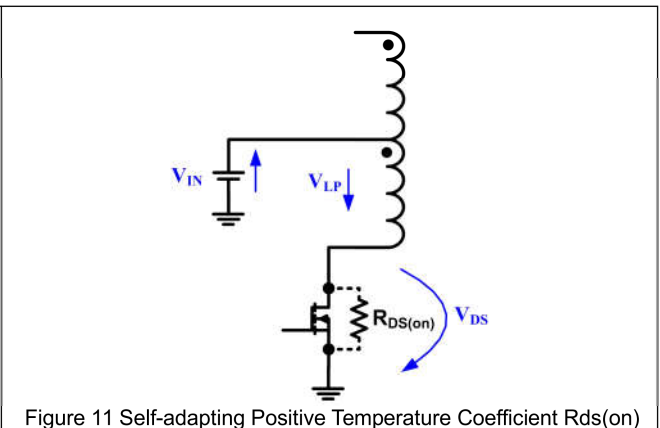

Figure 11 Self-adapting Positive Temperature Coefficient Rds(on)

Fortunately, the on resistance  $R_{DS(on)}$  of MOSFET has positive temperature coefficient, with which SCM1209A has the self-correcting effect to restrain the imbalance of volt-second. Under the condition that there is small deviation between the breakover time of two MOS transistors, the transistor which has longer breakover time  $t_{ON}$  generates more quantity of heat, and the temperature of the transistor rises to improve  $R_{DS(on)}$ , then in the breakover period when the load remains unchanged, the drain-source voltage of this transistor  $V_{DS}$  is relatively high, as shown in Figure 11, the voltage of primary winding  $V_{LP}$  conforms to the formula  $V_{LP} = V_{IN} - V_{DS}$ , thus the  $V_{LP}$  of the transistor which has larger  $t_{ON}$  will gradually decrease to make volt-second recover balance.

2020-10-13 正本 orig •

## Product Operation Mode

SCM1209A has three operation modes, which respectively are start-up mode, operation mode and short mode.

In start-up mode, SCM1209A provides sufficient charging time for output capacitor, to avoid the abnormal start caused by output short circuit which is incorrectly identified due to the excessive low voltage of output capacitor when it is just started; at the same time, the MOS transistor in start-up mode is always operating in current-limiting drive status which means that the drive voltage of MOS transistor in start is limited, thereby making the current flowing through MOS transistor restrained within the safe range of components, that is to restrain the output switching current of primary winding to  $I_{SOFT}$  to achieve the soft start of the system, thereby avoiding the over-current impact and the generation of excessive heat.

In operation mode, MOS transistor is always in full drive status which means that the MOS transistor is operating in switching status and the breakover voltage is very low, which guarantee the efficiency of converter.

In short mode, it will stop driving the converter in sleep mode and the heat generated in start-up mode will be dissipated, then the product changes to start-up mode.

The three operation modes can be freely switched. Only when there is abnormality of output short circuit, the product will repeatedly switch between the start-up mode and short mode; when the abnormality disappears, the product will automatically change to operation mode, all of which can fully guarantee the reliability of converter and have no influence on the performance of converter in normal operation.

## Start-up Mode

The voltage of output capacitor is zero when the converter is just started, and the converter is firstly in start-up mode. The flow diagram is shown in Figure 12, that is, start → Drive the selected MOS transistor in current-limiting drive method → check the switch-on voltages of MOS transistors ( $V_{VD1}$ ,  $V_{VD2}$ ) → judge whether the voltages ( $V_{VD1}$ ,  $V_{VD2}$ ) are more than the set value.

If ( $V_{VD1}$ ,  $V_{VD2}$ ) are more than the set value, then calculate the duration of over-voltage → judge whether the duration is more than  $T_{D\_OSP}$  (47ms, typ.). If yes, then the system turns into short circuit mode; if no, then the above process is repeated.

If ( $V_{VD1}$ ,  $V_{VD2}$ ) are not more than the set value, then the system turns into operation mode.

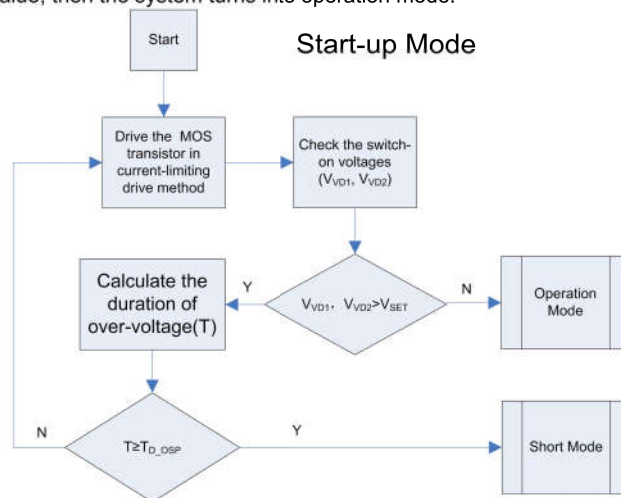

Figure 12 Flow Diagram of Start-up Mode

## Operation Mode

If the output of converter has no short circuit, the voltage of output capacitor, in start-up mode, will gradually increase during the continuously circular charging. When the breakover voltage of MOS transistor is less than or equal to the set value, the converter will turn into operation mode. The flow diagram is shown in Figure 13, that is, determine that the breakover voltage of MOS transistor is less than or equal to the set value → drive the selected MOS transistor with full drive → check the switch-on voltage of MOS transistors → judge whether the voltages ( $V_{VD1}$ ,  $V_{VD2}$ ) are more than the set value.

If the breakover voltage of MOS transistor is more than the set value, then the system goes into time-counting cycle of start-up mode; otherwise, the system turns back to the step “drive the selected MOS transistor with full drive”, and the above processes are repeated, which is the normal operation of the converter after the product is started. In the operation, MOS transistor is fully driven, that is the MOS transistor is operating in switching status and the on resistance is low, resulting in low energy consumption and high efficiency.

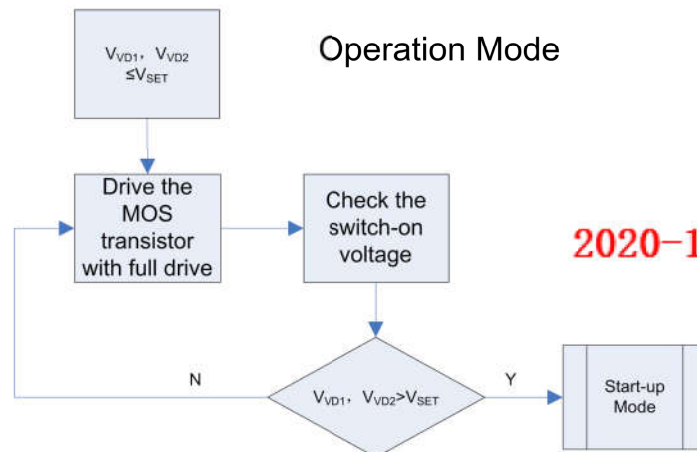

Figure 13 Flow Diagram of Operation Mode

2020-10-13 正本 orig

If the output of the converter has short circuit, it will detect in start-up mode that the breakover voltage of MOS transistor is more than the set value, then the accumulated over-voltage time will definitely exceed  $T_{D\_OSP}$  (47ms,typ.). At this time, SCM1209A will stop to drive the MOS transistor and begin to count the time of stopping driving MOS transistor. When the time is counted to  $T_{SLEEP}$  (1s,typ.), the product resumes operation and turns into start-up mode.

The flow diagram of short mode is shown as Figure 14: determine the duration of over-voltage exceeding  $T_{D\_OSP}$  → stop driving and begin to count time (sleep mode) → finish counting time → turn back to start-up mode. We can see that if the converter is always in output short circuit status, it will operate in the short mode and start-up mode alternately.

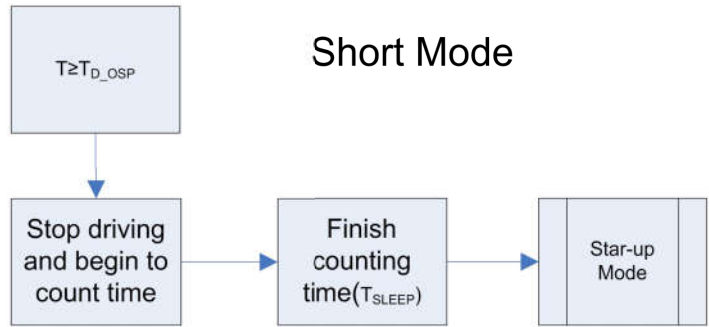

Figure 14 Flow Diagram of Short Mode

Extended Output Design

SCM1209A chip is used to drive the push-pull circuit, which can make output voltage become higher.

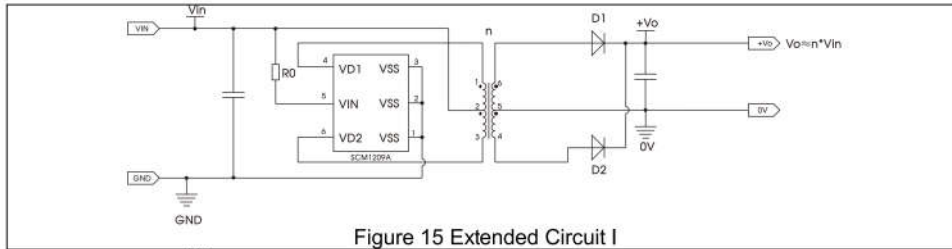

Figure 15 Extended Circuit I

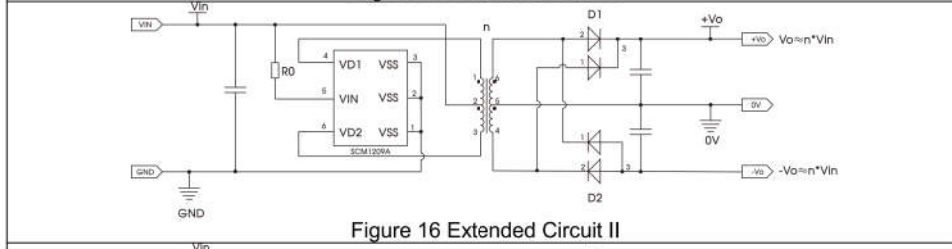

Figure 16 Extended Circuit II

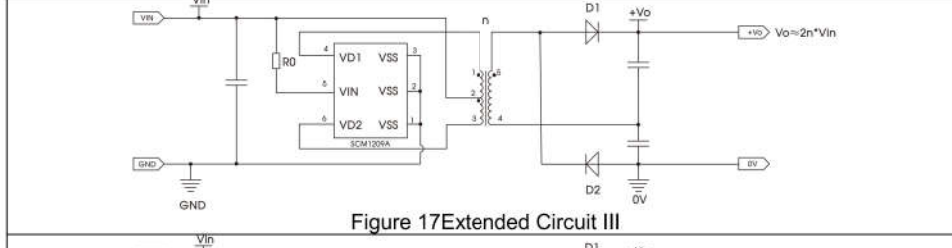

Figure 17 Extended Circuit III

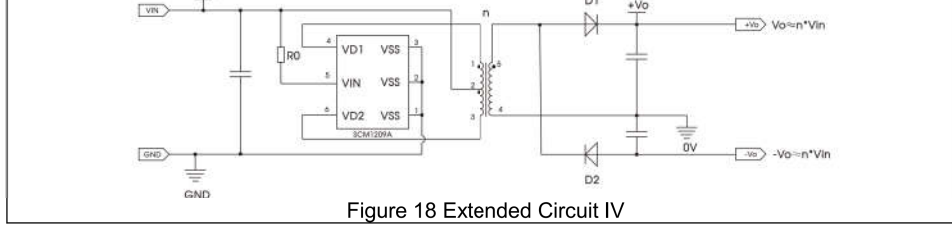

Figure 18 Extended Circuit IV

2020-10-13 正本 orig •

## Application Circuit

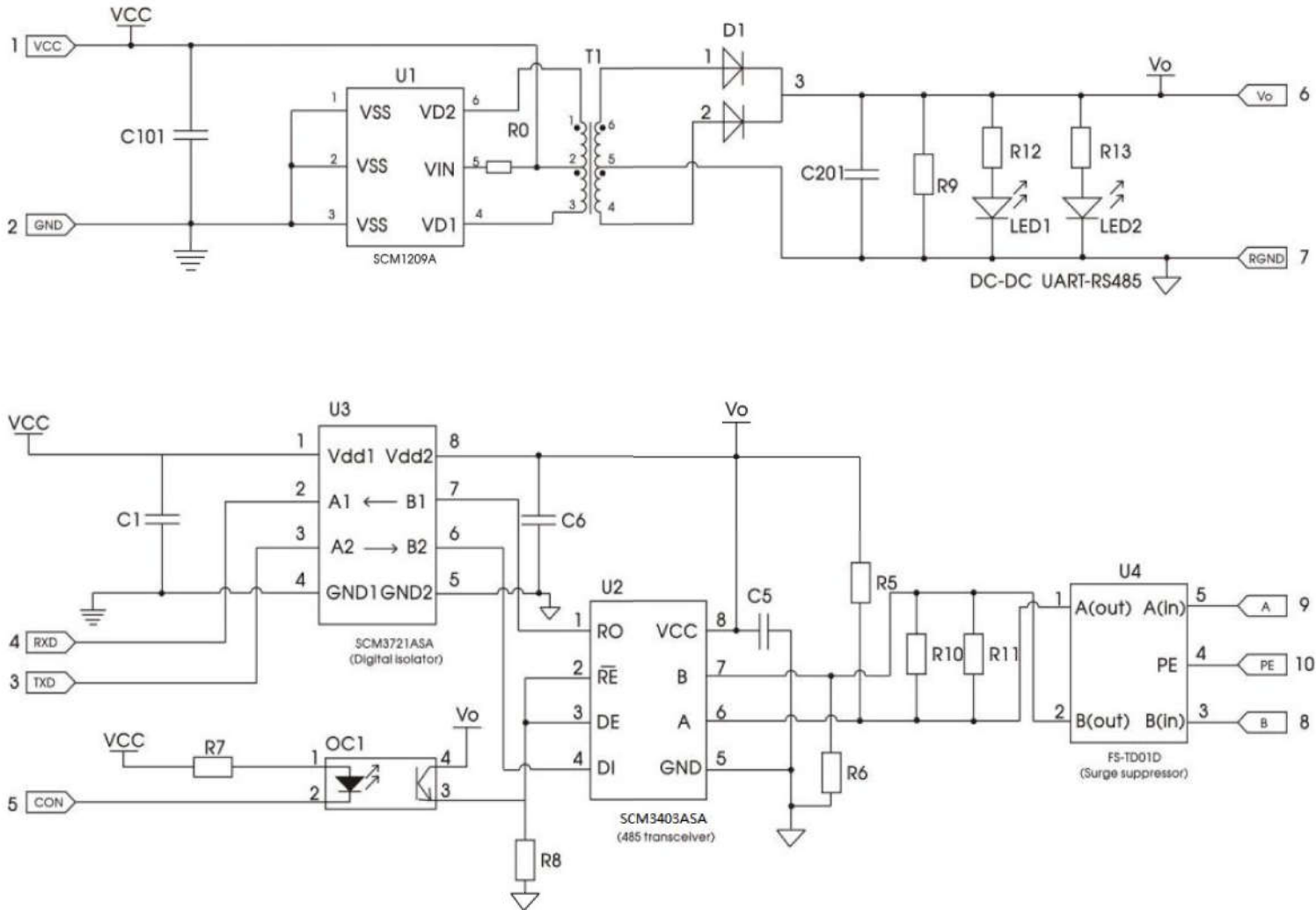

Figure 19 Application Circuit I

## Suggested Use of Power Supply

Unless otherwise specified, the following parameters are measured in the conditions of  $V_{IN} = 24V$ .

If the input power is not stable enough, it is suggested to add 1uF capacitor in the first section of IC SCM1209A; if there is high requirement to EMI performance, add capacitor and inductor in the first section of the module to filter noise; if there is high requirement to no-load voltage, add resistor after the filtering capacitor of the module as dummy load; it is suggested that the connecting wire of IC4 and 6 pins to the transformer is as short as possible..

## Ordering Information

Product Model	Packaging	Quantity of Pin	Silk Screen	Packing
SCM1209ATA	TSOT-23-6	6	1209YM	4K/Tray

Description of Product Model

SCM1209XYZ:

(1) SCM1209, product code.

(2) X = A-Z, version code.

(3) Y = T, packaging code. T:TSOT packaging.

(4) Z = C, I, A, M, code of temperature range. C: 0°C-70°C, I: -40°C-85°C, A: -40°C-125°C, M: -55°C-125°C.

2020-10-13 正本 orig •

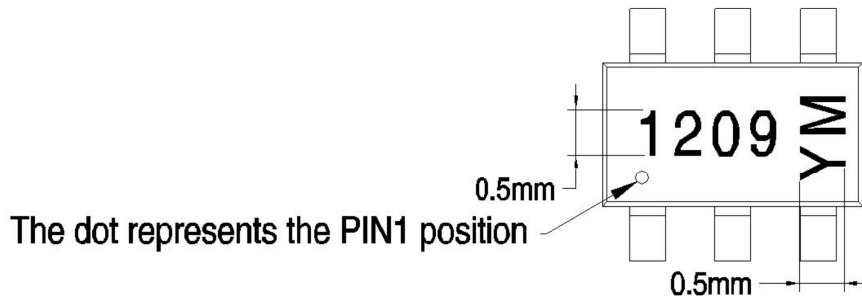

THIRD ANGLE PROJECTION

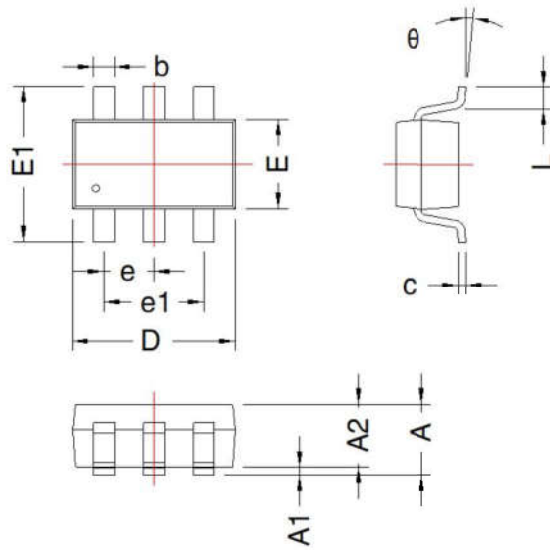

TSOT-23-6				
Mark	Dimension(mm)		Dimension(inch)	
	Min	Max	Min	Max
A	--	1.10	--	0.043
A1	0.00	0.10	0.000	0.004
A2	0.70	1.00	0.028	0.039
D	2.85	2.95	0.112	0.116
E	1.55	1.65	0.061	0.065
E1	2.65	2.95	0.104	0.116
L	0.30	0.60	0.012	0.024
b	0.30	0.50	0.012	0.020
e	0.95 TYP		0.037 TYP	
e1	1.90 TYP		0.075 TYP	
c	0.08	0.20	0.003	0.008
θ	0°	8°	0°	8°

2020-10-13 正本 orig •

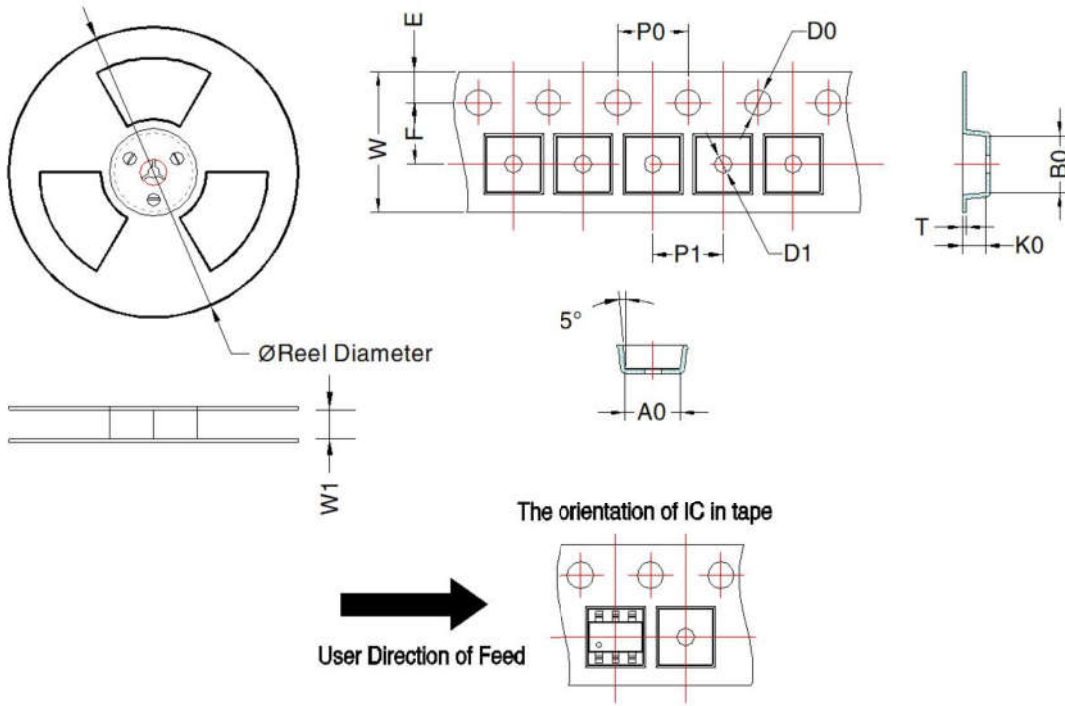

Device	Package Type	MPQ	Reel Diameter (mm)	Reel Width W1 (mm)	A0 (mm)	B0 (mm)	K0 (mm)	T (mm)	W (mm)	E (mm)	F (mm)	P1 (mm)	P0 (mm)	D0 (mm)	D1 (mm)
SCM1209ATA	TSOT-23-6	4000	180.0	8.5	3.17 ± 0.1	3.1 ± 0.1	1.1 ± 0.1	0.25 ± 0.03	8.0 ± 0.3	1.75 ± 0.1	3.5 ± 0.1	4 ± 0.1	4 ± 0.1	1.5 ± 0.1	1.0 ± 0.1

2020-10-13 正本 orig •

## Mornsun Guangzhou Science & Technology Co.,Ltd.

Address: No.5,Kehui St.1,Kehui Development Center,Science Ave.,Guangzhou Science City,huangpu District,Guangzhou,P.R.China

Tel: 86-20-38601850

Fax: 86-20-38601272

Email: info@mornsun.cn