

Single high-speed RS485 isolated transceiver module, SMD package

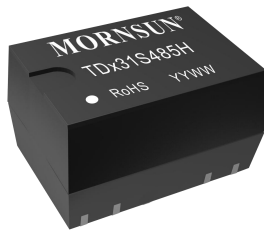

RoHS



EN62368-1

FEATURES

- Small size, SMD package
- Integrated high efficient isolated DC-DC converter
- High baud rate up to 150kbps
- Two-port isolation test voltage (2.5kVDC)
- Operating ambient temperature range: -40°C to +85°C
- The bus supports maximum 128 nodes
- Set isolation and ESD bus protection in one

The main function of the TD331S485H / TD531S485H series is to convert a logic level signal into isolated RS485 differential level signals. The special integrated IC technology of the RS485 transceiver achieves isolation between the power supply and the signal lines isolation, does RS485 communication and protects the bus all in one and the same module. The product's isolated power supply withstands a test voltage of up to 2500VDC. The products are using pick and place SMD technology, thus enabling the use of fully automated processing. Also, they can easily be embedded in the user's end equipment, to achieve fully functional RS485 network connections.

Selection Guide

Certification	Part No.	Power Input (VDC)	Baud Rate (bps)	Static Current (mA)	Maximum Operating Current (mA)	Isolated Power Output (typ.) (VDC)	Number of Nodes
EN	TD331S485H	3.15-3.45	150	28	130	5	128
	TD531S485H	4.75-5.25	150	38	130	5	128

Absolute Limits

Item	Operating Conditions	Min.	Typ.	Max.	Unit
Input Surge Voltage (1sec.max.)	3.3V series	-0.7	--	5	VDC
	5.0V series	-0.7	--	7	
Reflow Soldering Temperature	Peak temp. ≤245°C, duration ≤60s max.at 217°C. For details, please refer to IPC/JEDEC J-STD-020D.1.				

3.3V Input Specifications

Item	Symbol	Min.	Typ.	Max.	Unit	
Power Supply Input Voltage	V _{CC}	3.15	3.3	3.45	VDC	
TXD Logic Level	High-level	V _{IH}	0.7V _{CC}	--		3.6
	Low-level	V _{IL}	0	--		0.8
RXD Logic Level	High-level	V _{OH}	V _{CC} - 0.4	3.1		--
	Low-level	V _{OL}	0	0.2		0.4
TXD Drive Current	I _T	2	--	--		mA
CON Drive Current	I _{CON}	--	--	5		
RXD Output Current	I _R	--	--	3.5		
Serial Interface	Compatible with + 3.3 V UART interface only					

5.0V Input Specifications

Item	Symbol	Min.	Typ.	Max.	Unit	
Power Supply Input Voltage	V _{CC}	4.75	5	5.25	VDC	
TXD Logic Level	High-level	V _{IH}	0.7V _{CC}	--		5.5
	Low-level	V _{IL}	0	--		0.8
RXD Logic Level	High-level	V _{OH}	V _{CC} - 0.4	4.8		--
	Low-level	V _{OL}	0	0.2		0.4
TXD Drive Current	I _T	2	--	--		mA
CON Drive Current	I _{CON}	--	--	5		
RXD Output Current	I _R	--	--	3.5		

Serial Interface	Compatible with + 5 V UART interface only
------------------	---

Transmission Specifications						
Item		Symbol	Min.	Typ.	Max.	Unit
Data Delay	TXD Transmitter Delay	t_r	--	--	5	us
	RXD Receiver Delay	t_r	--	--	5	
Transceiver switching delay time	Switch from receiving data to sending data		--	5	18	
	Switch from sending data to receiving data		--	30	100	

Output Specifications						
Item		Symbol	Min.	Typ.	Max.	Unit
Difference Level		$V_{diff(\alpha)}$, $R_L=54\ \Omega$	1.5	2	--	VDC
Difference Load Resistance			54	--	--	Ω
Difference Input Impedance		$-7V \leq V_{CM} \leq +12V$	96	--	--	$k\ \Omega$
Built-in Pull-down Resistor			--	47	--	
Isolation Power Output Voltage*		Nominal input voltage	4.9	5	5.5	VDC
Bus Interface Protection			ESD protection			

Note: *Isolated output power pins are for external pull-up, pull-down resistors only (recommended maximum current <25mA) and are not meant for any other purpose.

Truth Table Specifications					
Transceiver Control	Input		Output		
	CON	TXD	A	B	RXD
Send Status	0	1	1	0	1
	0	0	0	1	1
Receive Status ^①	CON	V_A-V_B	RXD		
	1	$\geq -20mV$	1		
	1	$\leq -220mV$	0		
	1	$-220mV < V_A-V_B < -20mV$	Undefined state		

Note: ①Receiving threshold varies with Vcc will produce subtle error.

General Specifications		
Item	Operating Conditions	Value
Isolation Test	Electric strength test for 1 minute, leakage current <1mA	2500VDC
Insulation Resistance	At 500VDC	1000M Ω (input-output)
Operating Temperature		-40 $^{\circ}C$ to +85 $^{\circ}C$
Transportation and Storage Temperature		-50 $^{\circ}C$ to +105 $^{\circ}C$
Operating Humidity	Non-condensing	10% - 90%
Safety Standard		EN62368-1(Report)
Safety Class		CLASS III
Moisture Sensitivity Level (MSL)	IPC/JEDEC J-STD-020D.1	Level 1

Note: * For actual application, please refer to IPC/JEDEC J-STD-020D.1.

Mechanical Specifications	
Case Material	WH9100-F (UL94 V-0)
Dimensions	SMD12; Dimension 17.00 x 12.14 x 9.45mm
Weight	2.8g (Typ.)
Cooling Method	Free air convection

Electromagnetic Compatibility (EMC)				
Emissions	CE	CISPR32/EN55032 CLASS A (see Fig. 3)		
Immunity	ESD	IEC/EN 61000-4-2	Contact $\pm 4kV$ / Air $\pm 8kV$ (A, B port, without external components)	Perf. Criteria B
	EFT	IEC/EN 61000-4-4	$\pm 2kV$ (A, B port, without external components)	Perf. Criteria B
	Surge	IEC/EN 61000-4-5	$\pm 2kV$ (line to ground) (A, B port, without external components)	Perf. Criteria B

CS	IEC/EN 61000-4-6 3Vr.m.s (without external components)	Perf. Criteria A
----	--	------------------

Application Precautions

1. Carefully read and follow the instructions before use; contact our technical support if you have any question;
2. Do not use the product in hazardous areas;
3. Use only DC power supply source for this product. 220V AC power supply is prohibited;
4. It is strictly forbidden to disassemble the product privately in order to avoid product failure or malfunction;
5. Hot-swap is not supported;
6. If the external input of TXD is insufficient, the pull-up resistor should be added according to the situation.

After-sales service

1. Factory inspection and quality control are strictly enforced before shipping any product; please contact your local representative or our technical support if you experience any abnormal operation or possible failure of the module;
2. The products have a 3-year warranty period, from the date of shipment. The product will be repaired or exchanged free of charge within the warranty period for any quality problem that occurs under normal use.

Applied circuit

Refer to the RS485 Isolated Industrial Bus Interface Module Application Manual.

Design Reference

1. Typical application circuit

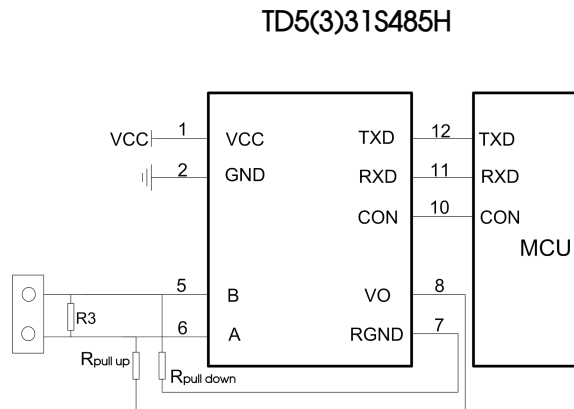

Fig. 1: Typical application

Figure 1 shows a typical connection circuit for the isolated transceiver module TD331S485H and TD531S485H. The TD531S485H module's power supply must be 5V and match the module's TXD, RXD and CON pin interface level of 5V (not supporting any 3.3V system levels). Accordingly, TD331S485H module's power supply must be 3.3V and match the module's TXD, RXD and CON pin interface level of 3.3V (not supporting any 5V system levels).

The module has a built-in 24kΩ pull-down resistor, which under normal circumstances meets the demand for the use of internal pull-up and pull-down resistors. Depending on the actual circuit, the use of additional external R pull-up and R pull-down resistor may be chosen.

2. Recommended port protection circuit

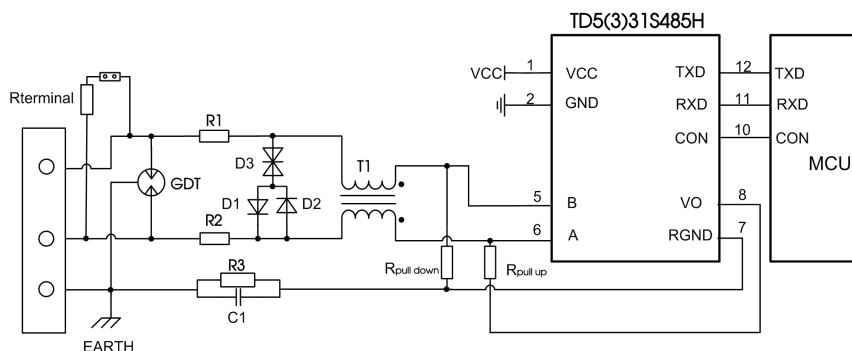

Fig. 2: Port protection circuit for harsh environments

Note: Ground shield of twisted wire pair reliably.

Recommended components and values:

Component	Recommended part, value	Component	Recommended part, value
R3	1MΩ	R1、R2	2.7Ω /2W
C1	1nF, 2kV	D1、D2	1N4007
T1	ACM2520-301-2P	D3	SMBJ8.5CA
GDT	B3D090L	Rterminal	120Ω

As the modules internal A / B lines come with its own ESD protection, which generally satisfy most application environments without the need for additional ESD protection devices, as shown in the typical circuit in Figure 1. For harsh and noisy application environments such as motors, high voltage/current switches, lightning and similar however, we recommended that the user protects the module's A / B lines with additional measures and external components such as TVS, common mode inductors, gas discharge tube, shielded twisted pair of wires with the same single network Earth point. Figure 2 shows our recommended circuit diagram for such type of applications with components and values given in the table above. This recommendation is for reference only and may have to be adapted accordingly with appropriate component values in order to match the actual situation and application.

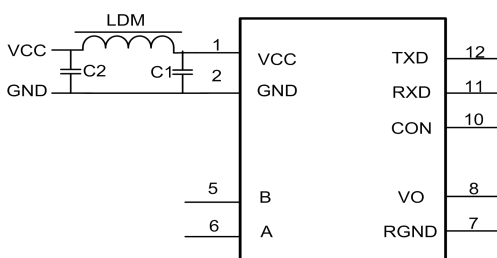

Component	Recommended part, value
C1, C2	1uF/16V
LDM	CD43-12uH

Fig.3

3. Precautions

- 1) TD531S485H is for 5V TTL level only (not compatible with 3.3V); TD331S485H is for 3.3V TTL level only (not compatible with 5V).
- 2) Pin3, Pin4 and Pin9 are not drawn. Please leave pin7 open if unused.
- 3) We recommend using a shielded twisted pair of wires for the Data transmission line and using same single point earth connection for each of the networks.
- 4) From the truth table characteristics, it can be derived that the isolated RS-485 transceiver module's CON pin is low to send data and high when receiving data. Note that the general 485 transceiver chip control level is exactly the opposite, therefore, if the customer desires to change the level to the ordinary 485 transceiver chip control level, we recommend using a transistor circuit between the MCU and the CON feed to reverse this signal.
- 5) Reference the truth table characteristics: When the A / B line differential voltage of the series of embedded isolated RS-485 transceiver module is $\geq -10\text{mV}$, the modules receiving level is high and when the A / B line differential voltage is $\leq -200\text{mV}$ the modules receiving level is low; the modules receiving level is undefined when the A / B line differential voltage is greater than -200mV but less than -10mV , so the design is to ensure that the module will not be receiving this state. Depending on the actual situation, it is up to the user of the RS-485 network design or application to decide whether to add a 120Ω termination resistor. Avoiding data communication errors: Regardless if the RS-485 network is static or dynamic, it is essential to avoid that the differential voltage of A / B line ever comes between -200mV and -10mV .

4. For additional information, please refer to our application note on www.mornsun-power.com

Dimensions and Recommended Layout

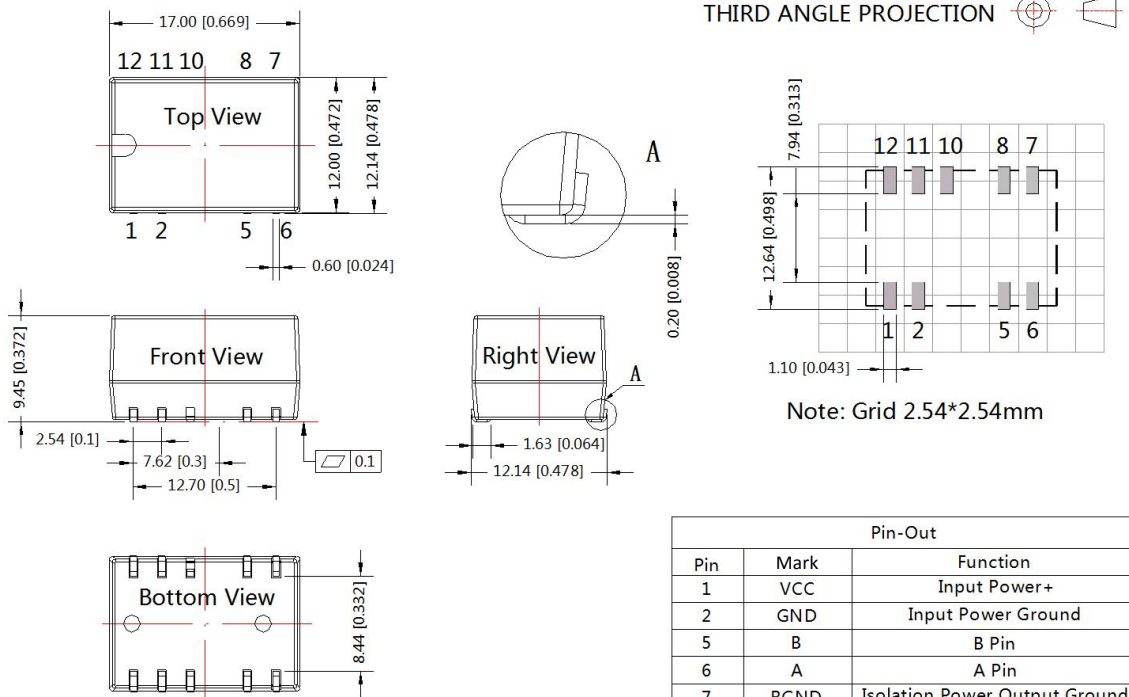

Pin-Out		
Pin	Mark	Function
1	VCC	Input Power+
2	GND	Input Power Ground
5	B	B Pin
6	A	A Pin
7	RGND	Isolation Power Output Ground
8	VO	Isolation Power Output+
10	CON	Sending/Receiving Control Pin
11	RXD	Receiving Pin
12	TXD	Sending Pin

Note:
Unit: mm[inch]
Pin section tolerances: $\pm 0.10[\pm 0.004]$
General tolerances: $\pm 0.25[\pm 0.010]$

Package diagram:

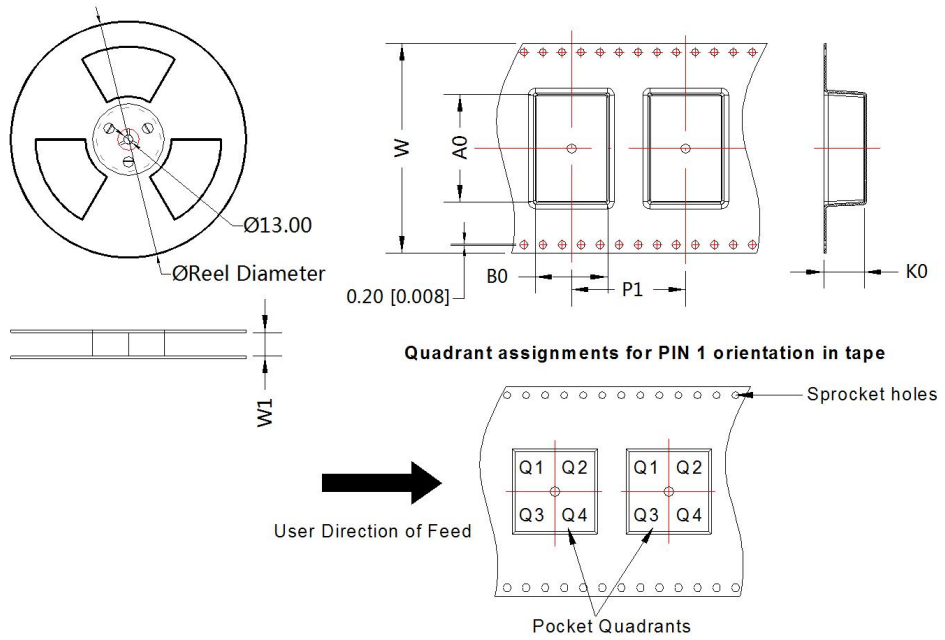

Device	Package Type	Pin	SPQ	Reel Diameter (mm)	Reel Width W1 (mm)	A0 (mm)	B0 (mm)	K0 (mm)	P1 (mm)	W (mm)	Pin1 Quadrant
TDx31S485	SMD	9	300	330.0	32.5	17.72	12.92	10.5	20.0	32.0	Q1
TDx31S485H	SMD	9	300	330.0	32.5	17.72	12.92	10.5	20.0	32.0	Q1
TDx31S485H-E	SMD	9	300	330.0	32.5	17.72	12.92	10.5	20.0	32.0	Q1
TDx31S485H-A	SMD	9	300	330.0	32.5	17.72	12.92	10.5	20.0	32.0	Q1

Notes:

1. For additional information on Product Packaging please refer to www.mornsun-power.com. The Tube Packaging bag number: 58240014; The Roll Packaging bag number: 58240013;
2. Unless otherwise specified, parameters in this datasheet were measured under the conditions of $T_a=25^{\circ}\text{C}$, humidity<75%RH with nominal input voltage and rated output load;
3. All index testing methods in this datasheet are based on company corporate standards;
4. The performance indexes of the product models listed in this datasheet are as above, but some indexes of non-standard model products will exceed the above-mentioned requirements, and please directly contact our technician for specific information;
5. We can provide product customization service, please contact our technicians directly for specific information;
6. Products are related to laws and regulations: see "Features" and "EMC";
7. Our products shall be classified according to ISO14001 and related environmental laws and regulations, and shall be handled by qualified units.

MORNSUN Guangzhou Science & Technology Co., Ltd.

Address: No. 5, Kehui St. 1, Kehui Development Center, Science Ave., Guangzhou Science City, Huangpu District, Guangzhou, P. R. China
Tel: 86-20-38601850 Fax: 86-20-38601272 E-mail: info@mornsun.cn www.mornsun-power.com